

Item No.:	_____	Qty.	_____
Model No.:	_____		
Project No.:	_____		



14" Standard Series Sinks

14" Deep Standard Series Three Compartment Stainless Steel Sinks

- | | |
|---|---|
| <input type="checkbox"/> 14-3C16X20-2-18X | <input type="checkbox"/> 14-3C18X24-2-18X |
| <input type="checkbox"/> 14-3C16X20-2-24X | <input type="checkbox"/> 14-3C18X24-2-24X |
| <input type="checkbox"/> 14-3C20X20-2-20X | <input type="checkbox"/> 14-3C24X24-2-24X |

Options

- Faucets
- Tub Accessories
- Undershelves
- Rotary Drain Options
- H-Frame Stainless Steel Legs
- Stainless Steel Feet Options (bullet & flange styles)

Specifications

14" Standard Series Sink, with three compartments, both left and right drainboards, 9" backsplash, 16 gauge, 300 series stainless steel top and bowl, galvanized legs & adjustable feet, raised 1-1/2" rolled edge, includes 3-1/2" basket strainer, NSF approved

Features

- - 16 Ga. stainless steel
- - Welded construction for consistent metal gauge thickness throughout
- - 14" (355.6 mm) deep tub with 3/4" (19.1 mm) covered radius tub corners
- - All drainboards are die stamped for positive drainage
- - 9" (228.6 mm) backsplash with tile ledge for easy installation
- - Raised 1-1/2" (38.1 mm) diameter rolled edge
- - 3-1/2" (88.9 mm) drain with basket strainers included
- - 1-5/8" (41.3 mm) galvanized legs with 1" (25.4 mm) adjustable plastic feet
- - 2" (50.8 mm) divider between each tub

Flyer Product

In keeping with our policy of continuing product improvement, Elkay SSP reserves the right to change product specifications without notice.

Materials

- Sink & Bowl: 16 Ga. 300 series stainless steel
- - Top: Drainboards and backsplash are 16 gauge 300 series stainless steel.
- - Legs: All sinks furnished with 1-5/8" (41.3 mm) diameter heavy gauge galvanized tubing with plated galvanized leg gussets and high impact corrosion resistant fully adjustable 1" (25.4 mm) feet.

Mechanical

- 1-1/8" (28.6mm) faucet holes on 8" (203mm) centers
- 3-1/2" (88.9mm) waste drain opening



AUTOQUOTES



This specification describes an Elkay SSP product with design, quality and functional benefits to the user. When making a comparison of other producers' offerings, be certain these features are not overlooked.



Item No.: _____ Qty. _____

Model No.: _____

Project No.: _____

14" Standard Series Sinks

14" Deep Standard Series Three Compartment Stainless Steel Sinks

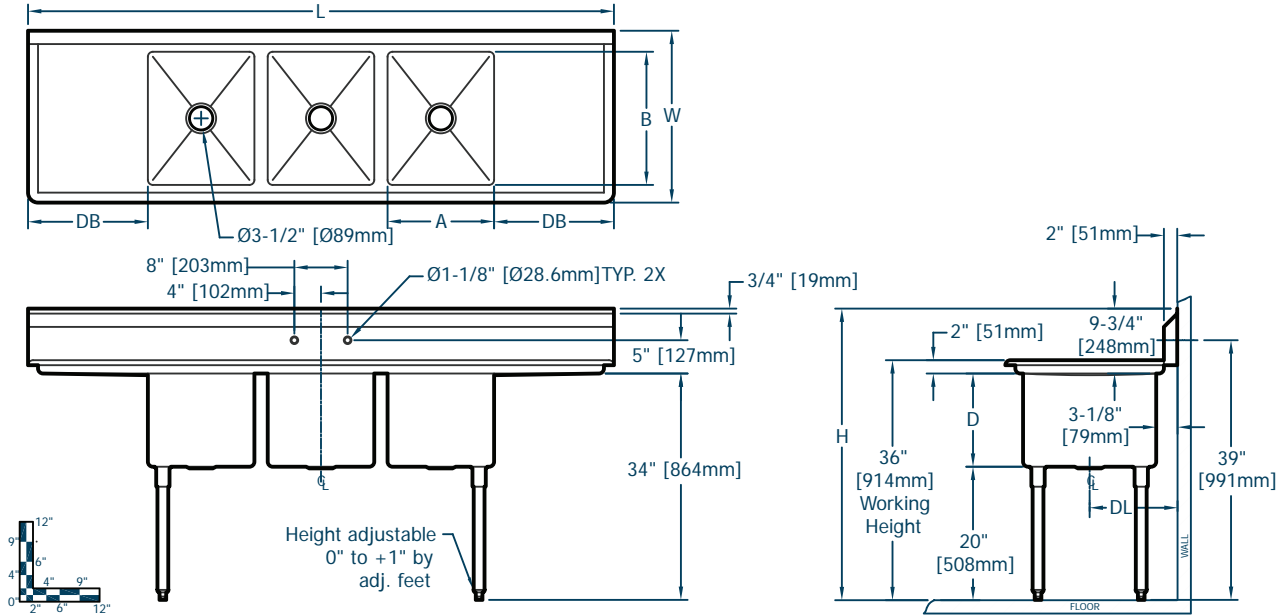

14" Standard Series Sinks																		
Model Number	Bowl Dimensions						Overall Size						Drainboard		Drain		Weight	
	Width		Front-to-Back		Depth		Length		Width		Height		Location	Size	Location			
	A	B	D		L	W	H		DB	DL	lbs.	kg						
	in.	mm	in.	mm	in.	mm	in.	mm	in.	mm	in.	mm	in.	mm	in.	mm	lbs.	kg
14 3C 16 X 20 2 18 X	16	406	20	508	14	356	88	2235	25.8	656	43.8	1111	L & R	18 457	13 330	305	139	
14 3C 16 X 20 2 24 X	16	406	20	508	14	356	100	2540	25.8	656	43.8	1111	L & R	24 610	13 330	319	145	
14 3C 20 X 20 2 20 X	20	508	20	508	14	356	104	2642	25.8	656	43.8	1111	L & R	20 508	13 330	366	166	
14 3C 18 X 24 2 18 X	18	457	24	610	14	356	94	2388	29.8	757	43.8	1111	L & R	18 457	15 381	349	158	
14 3C 18 X 24 2 24 X	18	457	24	610	14	356	106	2692	29.8	757	43.8	1111	L & R	24 610	15 381	364	165	
14 3C 24 X 24 2 24 X	24	610	24	610	14	356	124	3150	29.8	757	43.8	1111	L & R	24 610	15 381	443	201	

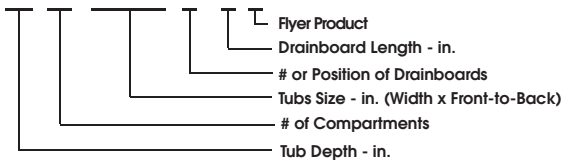

Elkay SSP
 421 N. Freya St.
 Spokane, WA 99205
 Phone: 800-726-0553 Fax: 509-535-1493

Website: www.sspinc.net
 Email: sspsales@elkay.com
 ©2011 SSP INC.