

HOBART701 S Ridge Avenue, Troy, OH 45374
1-888-4HOBART • www.hobartcorp.com**HCM61 BOWL-STYLE
FOOD PROCESSOR****HOBART****STANDARD FEATURES**

- 1.5 H.P. Direct Drive Motor
- Patented Bowl Scraper and Integrated Lid Wiping System
- Durable Polysulphone Cover with Bowl Gasket
- Hobart COOLCUTTER Knives
- Knife Speed of 1725 RPM
- Triple Safety Interlock
- User-Friendly Controls
- Compact Design
- Anodized Aluminum Base with Powdercoated Top Cover

MODEL

- HCM61 – Hobart 6 Quart, Single Speed Bowl-Style Food Processor

Specifications, Details and Dimensions on Inside and Back.

ACCESSORIES

- Six Quart COOLCUTTER Cut/Mix Knives
- Additional Six Quart Bowls Available for Large Volume Operations

**HCM61 BOWL-STYLE FOOD PROCESSOR**

HCM61 BOWL-STYLE FOOD PROCESSOR

HOBART701 S Ridge Avenue, Troy, OH 45374
1-888-4HOBART • www.hobartcorp.com

SOLUTIONS / BENEFITS

Direct Drive Motor

Durability

- 1.5 H.P., 15.4 rated amps, direct driven.
- Prevents stalling and slipping.

Patented Bowl-Scraper and Integrated Lid Wiping System

Labor savings

- No need to stop unit and scrape side of bowl, plus the integrated lid wipers provide easy viewing of product during processing.

Polysulphone Cover with Bowl Gasket

Durability, ease of use

- See-through design allows continuous view of product. Bowl gasket seals in wet/moist product and prevents leaking. Large feed tube makes it easy to add ingredients while processing.

COOLCUTTER Knives

Consistency, productivity

- Exclusive COOLCUTTER knives increase productivity and product consistency while minimizing product temperature rise.
- COOLCUTTER utilizes two stainless steel serrated cutting knives and two stainless steel turning knives, which force product into the cutting knives resulting in reduced processing time.

1725 RPM Knife Speed

Performance

- Ideal speed for chopping and mixing foods.

Triple Safety Interlock

Safety

- Three interlocks prevent operation unless: (1) bowl is in place; (2) bowl cover is in place; and (3) lid lock arm is in place.
- Mechanical brake stops the blade in three seconds.

User Friendly Controls

Ease of use

- Easy to operate ON, OFF and PULSE settings.

Compact Design

Reduced space requirement

- Occupies minimal counter space.
- Handles are molded on both sides of housing for ease of moving unit.

Anodized Aluminum Base with Powdercoated Top Cover

Durability, improved sanitation

- Easy cleanup and durable finish.
- Rubber feet on base, prevents movement.

SPECIFICATIONS

Motor: 1.5 H.P.

Electrical: 120/60/1, 15.4 rated amps.

Cord and Plug: 3 conductor with power cord (12AWG) which is 8 feet in length with NEMA 5-20P plug.

Switch: ON, OFF and PULSE switch.

Footprint: 12" W x 18½" H x 13½" D (16" D with safety arm swing).

Finish: Anodized aluminum with powdercoated top cover.

Weight: Net 60 lbs. Shipping: approximately 62 lbs.

DETAILS AND DIMENSIONS

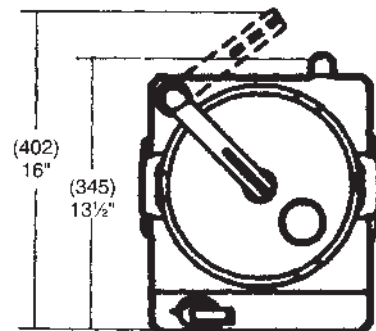
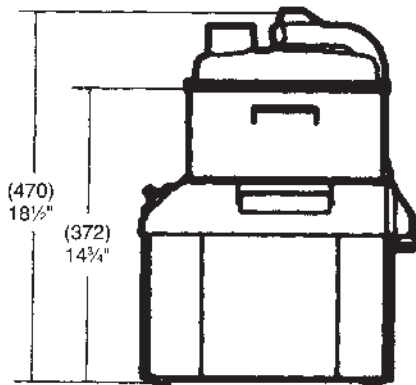
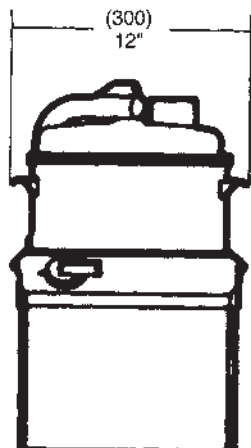

5-20P
Plug



Plug Configuration

As continued product improvement is a policy of Hobart, specifications are subject to change without notice.