

**HOBART**701 S Ridge Avenue, Troy, OH 45374  
1-888-4HOBART • www.hobartcorp.com**HCM62 BOWL-STYLE  
FOOD PROCESSOR****HOBART****STANDARD FEATURES**

- 2.0 H.P. Direct Drive Motor
- Patented Bowl Scraper and Integrated Lid Wiping System
- Durable Polysulphone Cover with Bowl Gasket
- Hobart COOLCUTTER Knives
- Knife Speeds of 1500 RPM and 3000 RPM
- Triple Safety Interlock
- User-Friendly Controls
- Compact Design
- Anodized Aluminum Base with Powdercoated Top Cover

**MODEL**

- HCM62 – Hobart 6 Quart, Two Speed Bowl-Style Food Processor

Specifications, Details and Dimensions on Inside and Back.

**ACCESSORIES**

- Six Quart COOLCUTTER Cut/Mix Knives
- Additional Six Quart Bowls Available for Large Volume Operations

**HCM62 BOWL-STYLE FOOD PROCESSOR**

# HCM62 BOWL-STYLE FOOD PROCESSOR

## HOBART

701 S Ridge Avenue, Troy, OH 45374  
1-888-4HOBART • www.hobartcorp.com

### SOLUTIONS/BENEFITS

#### Direct Drive Motor

##### Durability

- 2.0 H.P., 6.0/5.0 rated amps, direct driven.
- Prevents stalling and slipping.

#### Patented Bowl-Scraper and Integrated Lid Wiping System

##### Labor savings

- No need to stop unit and scrape side of bowl, plus the integrated lid wipers provide easy viewing of product during processing.

#### Polysulphone Cover with Bowl Gasket

##### Durability, ease of use

- See-through design allows continuous view of product. Bowl gasket seals in wet/moist product and prevents leaking. Large feed tube makes it easy to add ingredients while processing.

#### COOLCUTTER Knives

##### Consistency, productivity

- Exclusive COOLCUTTER knives increase productivity and product consistency while minimizing product temperature rise.
- COOLCUTTER utilizes two stainless steel serrated cutting knives and two stainless steel turning knives, which force product into the cutting knives resulting in reduced processing time.

#### 1500 RPM and 3000 RPM Knife Speeds

##### Performance

- Ideal speed for emulsifying and pureeing foods.

#### Triple Safety Interlock

##### Safety

- Three interlocks prevent operation unless: (1) bowl is in place; (2) bowl cover is in place; and (3) lid lock arm is in place.
- Mechanical brake stops the blade in three seconds.

#### User Friendly Controls

##### Ease of use

- Easy to operate OFF, LOW, HIGH and PULSE settings.

#### Compact Design

##### Reduced space requirement

- Occupies minimal counter space.
- Handles are molded on both sides of housing for ease of moving unit.

#### Anodized Aluminum Base with Powdercoated Top Cover

##### Durability, improved sanitation

- Easy cleanup and durable finish.
- Rubber feet on base, prevents movement.

### SPECIFICATIONS

**Motor:** 2.0 H.P.

**Electrical:** 208-240/60/3, 6.0/5.0 rated amps.

**Cord and Plug:** 3 conductor with power cord (16AWG) which is 6 feet in length with NEMA L15-20P plug.

**Switch:** OFF, LOW, HIGH and PULSE switch.

**Footprint:** 12" W x 18½" H x 13½" D (16" D with safety arm swing).

**Finish:** Anodized aluminum with powdercoated top cover.

**Weight:** Net 60 lbs. Shipping: approximately 62 lbs.

### DETAILS AND DIMENSIONS

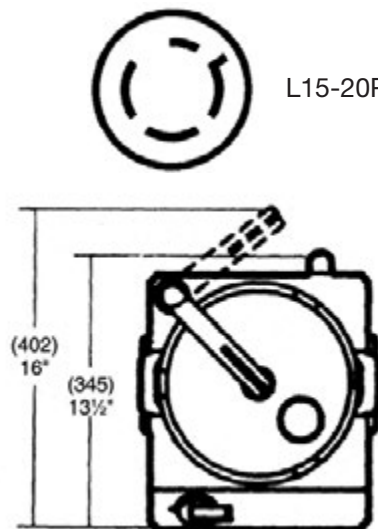
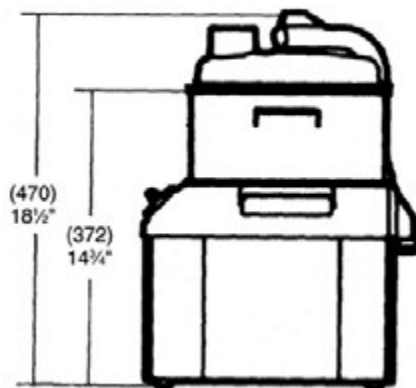

As continued product improvement is a policy of Hobart, specifications are subject to change without notice.