

HOBART701 S Ridge Avenue, Troy, OH 45374
1-888-4HOBART • www.hobartcorp.com**SDPE/SDPS
SALAD DRYER****HOBART****STANDARD FEATURES**

- ¼ HP motor with thermal overload
- Permanently lubricated gear drive
- 406 RPM gently spins water off
- Polyethylene outer tub and lid with fully sealed polyethylene base on SDPE
- Stainless steel outer tub and lid with fully sealed polyethylene base on SDPS
- Stainless steel motor splashguard
- Easy to reach 5 minute timer conveniently located at the top of the tub
- Easy load polyethylene spin basket with hand grips
- Drain pipe extension tube drains into floor drain or container up to 9" high
- Easy to lock, large casters, for easy mobility
- Seven foot 3-wire cord and plug

ACCESSORY

- Extra spin basket

MODEL

- SDPE – All Polyethylene Salad Dryer, 115/60/1
- SDPS – Stainless Steel Salad Dryer, 115/60/1

Specifications, Details and Dimensions on Inside and Back.

**Model SDPE****Model SDPS****SDPE/SDPS SALAD DRYER**

SDPE/SDPS SALAD DRYER



701 S Ridge Avenue, Troy, OH 45374
1-888-4HOBART • www.hobartcorp.com

SPECIFICATIONS

MOTOR: ¼ HP, 2.5 amps gear motor with thermal overload and permanently lubricated gear drive.

ELECTRICAL: 115/60/1 or 220/60/1. The 220V machine has not been submitted to UL for listing.

SWITCH: 5 minute timer

CORD & PLUG: 7 foot 3-wire cord and grounding type plug.

HOUSING: All polyethylene outer tub and lid and a polyethylene, one-piece molded, fully sealed base on the SDPE. All stainless steel outer tub and lid and a polyethylene, one-piece molded, fully sealed base on

SDPS. Stainless steel motor splash guard protects fully sealed motor.

BASKET: Easy to load polyethylene spin basket with hand grips.

DRAIN: Water drains through PVC extension tube directly into floor drain or container up to 9" high without splashing.

CASTERS: Easy to lock, heavy duty casters with brakes.

WARRANTY: Unit has a full one-year warranty on parts, labor and mileage against manufacturer's defects.

DETAILS AND DIMENSIONS

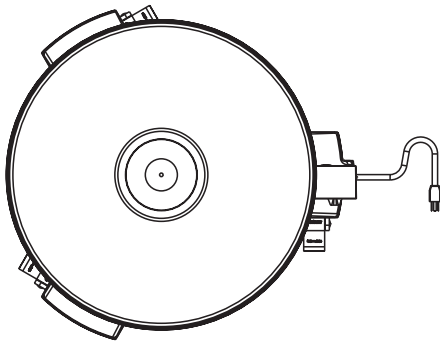

7 FOOT
POWER CORD STANDARD
(SINGLE PHASE MACHINES)

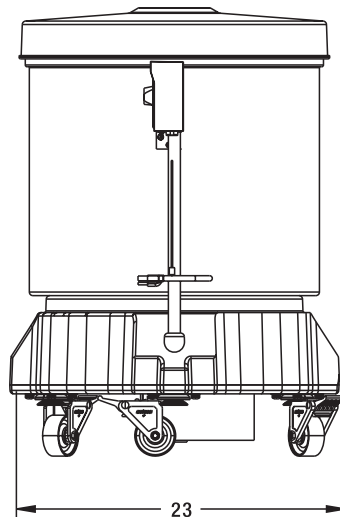
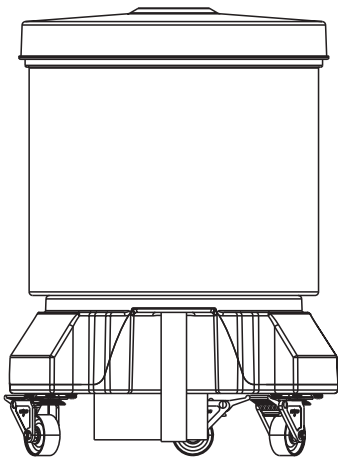
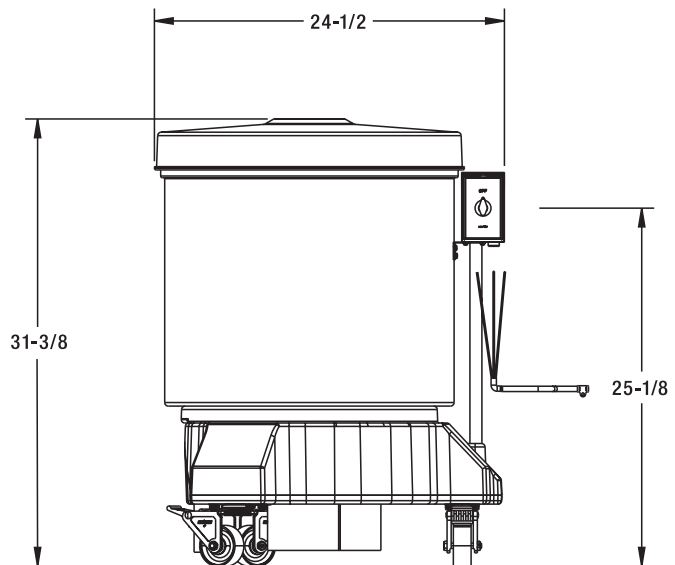

	SDPE	SPDS
Machine Weight -	60 lbs.	75 lbs.
Shipping Weight	88 lbs.	113 lbs.
Motor	¼ HP 115/60/1 2.5 Amps 406 RPM Output	¼ HP 115/60/1 2.5 Amps 406 RPM Output

WARNING

ELECTRICAL AND GROUNDING CONNECTIONS MUST COMPLY WITH THE APPLICABLE PORTIONS OF THE NATIONAL ELECTRICAL CODE AND/OR OTHER CODES IN FORCE

As continued product improvement is a policy of Hobart, specifications are subject to change without notice.