

INSTRUCTIONAL VIDEOS  
VIDEOS INSTRUCTIVOS  
VIDÉOS INSTRUCTIVES

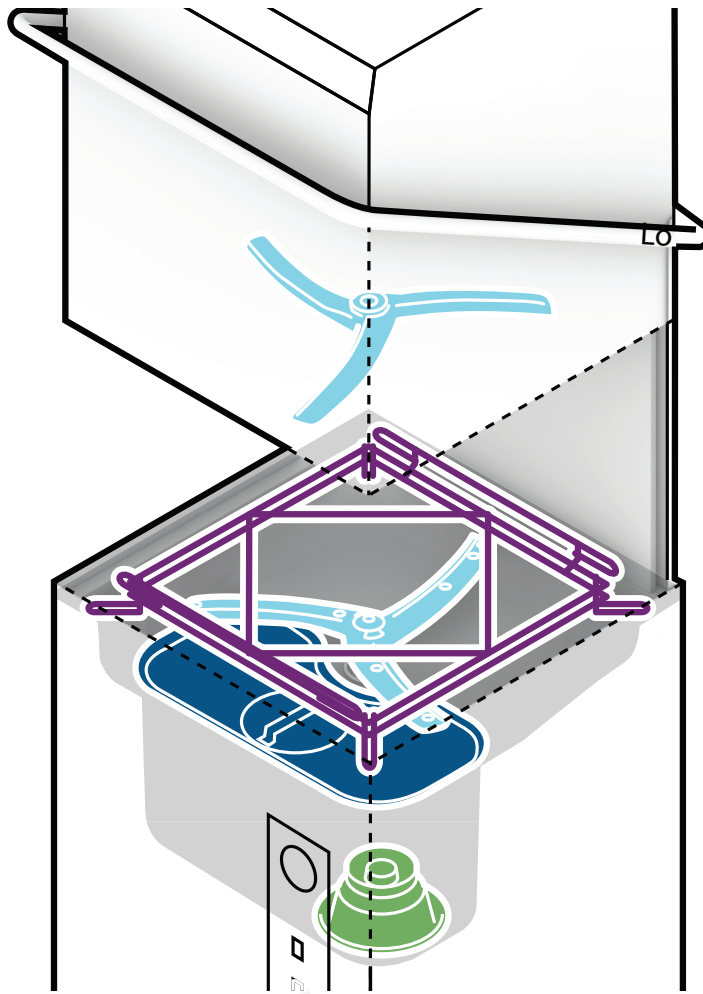

**Assemble**  
Armar  
Assembler

**Startup**  
Puesta en marcha  
Mise en marche

**Cycle**  
Ciclo  
Cycle

**EXTENDED CYCLE**  
CICLO EXTENDIDO  
CYCLE PROLONGÉ

**Shut Down**  
Apagar  
Fermeture

**Clean Up**  
Limpiar  
Nettoyer

**CDL Unit**

**CHEMICAL LEVELS**  
NIVELES QUÍMICOS  
NIVEAUX CHIMIQUES

**Operation Tips | Consejos de operación | Conseils d'utilisation**

**PRE-SCRAP DISHES**  
PLATOS PREVACIADOS  
TREMPER LA VAISSELLE

**DO NOT OVERLOAD RACKS**  
NO SOBRECARGUE LOS CESTOS  
NE PAS SURCHARGER PAS LES PANIERS

**CHECK CHEMICALS**  
COMPRUEBE LOS PRODUCTOS QUÍMICOS  
VÉRIFIER LES PRODUITS CHIMIQUES

**USE COMMERCIAL CHEMICALS ONLY**  
USE SOLO PRODUCTOS QUÍMICOS COMERCIALES  
UTILISER UNIQUEMENT DES PRODUITS CHIMIQUES COMMERCIAUX

**DELIME MACHINE AS NEEDED**  
DESCALCIFIQUE LA MÁQUINA  
COMO SEA NECESARIO  
DÉTARTRE LA MACHINE AU BESOIN

# centerline

by **HOBART**

CDH/CDL



SCAN TO WATCH MENU PROGRAMMING VIDEO

CUH/CUL



## PROGRAM SETTINGS – Access Changing Parameters

1. Press Menu Button 

2. **EXIT MENU** – OPEN door and close

**00** = Extended Wash – 3-6 minute limit



**01** = Cycle Count – Counter reading has 6 digits (012345 cycle)



For CUH, CUL, CDL & CDH Models equipped with internal chemical pumps

**02** = Detergent Dispensing – 0.0-20.0g/l



**03** = Prime Detergent Pump – Repeat as needed to prime the line



**04** = Rinse Aid Dispensing – 0.0-2.0g/l



**05** = Prime Rinse Aid Pump – Repeat as needed to prime the line



## For CUL & CDL Models Only

### 06 = Sanitizer Dispensing – Range can be 0-100%



### 07 = Prime Sanitizer Pump – Repeat as needed to prime the line

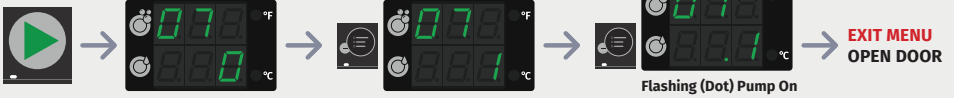

### 08 = Temperature Label (°F/°C)



## For CDH Model Only

### 09 = Chemical Pump Control



Setting	Chemical Pump Control Configuration
0	Internal chemical dosing pumps and external chemical signals disabled
1	Control of internal chemical dosing pumps enabled
2	Control signals for external chemical supply enabled

### 13 = Software Version / Machine Program



# centerline

CDH/CDL

by **HOBART**

CUH/CUL



SCAN TO VISIT THE  
CENTERLINE™ RESOURCE CENTER



## OPERATION and ERROR CARD

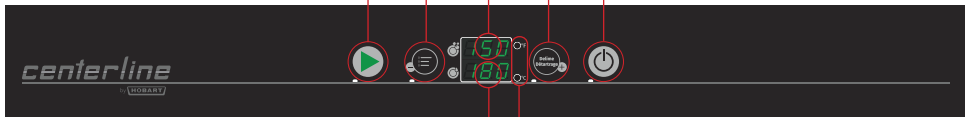

### 1. POWER/DRAIN BUTTON

Pressing this button switches the machine on, fills and heats the wash tank. Pressing and holding (3 seconds) activates self-cleaning cycle, drains machine, and then switches the machine off automatically. After machine is switched off, however, the machine still has voltage.

### 2. START BUTTON CUH & CUL

Pressing this button starts the wash cycle. If pressed a 2nd time within 10 seconds of the first press, the extended wash cycle is activated.

### CDH & CDL

After closing the door to start the wash cycle, pressing this button within 10 seconds of the cycle starting activates the extended wash cycle.

### 3. MENU BUTTON\*

Pressing this button enters the configuration menu.

### 4. DELIME BUTTON\*

Pressing and holding (3 seconds) activates the deliming cycle.

### 5. TEMPERATURE DISPLAY, WASH TANK

Displays wash tank temperature while machine is in ready state or in a wash cycle.

### 6. TEMPERATURE DISPLAY, RINSE

Displays rinse temperature only when rinse is active.

### 7. TEMPERATURE UNITS

LED lights for °F or °C.

### WASH PROGRAM

#### CUH & CUL

*Normal wash*  
for average soiled dishes – 2 minutes  
*Extended wash*  
for heavy soiled dishes – 3 to 6 minutes\*

#### CDH & CDL

*Normal wash*  
for average soiled dishes – 1 minute  
*Extended wash*  
for heavy soiled dishes – 3 to 6 minutes\*

\*For more detail review Operation and Install manual

ERROR CODE	SYMPTOM	POSSIBLE SOLUTION*
01	Booster Temperature Temperature above upper limit	<ol style="list-style-type: none"> <li>1. Press the power button to power off (Provide 20 min to cool off).</li> <li>2. Restart as normal.</li> <li>3. If error continues to display, possible high limit trip or heating element malfunction – contact Hobart Service.</li> </ol>
02	Booster Temperature Temperature below lower limit	<ol style="list-style-type: none"> <li>1. Press the power button to power off.</li> <li>2. Restart as normal.</li> <li>3. If error continues to display, possible high limit trip or heating element malfunction – contact Hobart Service.</li> </ol>

ERROR CODE	SYMPTOM	POSSIBLE SOLUTION*
03	Rinse Assurance Booster did not meet temperature or water level requirements	1. When booster does not reach temperature or water level set point, a long wash cycle of 10 to 20 minutes will trigger. 2. If error continues to display on next cycle, possible high limit trip or heating element malfunction – contact Hobart Service.
05	Wash Tank Temperature Temperature above upper limit	1. Press the power button to power off (Provide 20 min to cool off). 2. Restart as normal. 3. If error continues to display, possible high limit trip or heating element malfunction – contact Hobart Service.
06	Wash Tank Temperature Temperature below lower limit	1. Press the power button to power off. 2. Restart as normal. 3. If error continues to display, possible high limit trip or heating element malfunction – contact Hobart Service.
07	Booster Pressure Level Sensor Voltage above upper limit	1. Press the power button off then on to start the draining process. 2. Drain tank and refill (should reset the pressure level sensors). 3. If error continues to display – contact Hobart Service.
08	Booster Pressure Level Sensor Voltage below lower limit	
09	Wash Tank Pressure Level Sensor Voltage above upper limit	
10	Wash Tank Pressure Level Sensor Voltage below lower limit	
12	Drain Overflow Limit Wash tank water level exceeded limit	1. Verify drain hose is not pinched or kinked. 2. Verify pump strainer is not clogged. 3. If error continues to display, possible drain pump malfunction – contact Hobart Service.
13	Wash Tank Fill Time Exceeded	1. Cycle power button off and then on to continue filling. 2. Check wash and rinse arms for clogged nozzles. 3. If error continues to display – contact Hobart Service.
14	Drain Error – Shutdown Machine took too long to drain	1. Verify drain hose is not pinched, kinked or incorrect drain connection to building drain. 2. Check drain hose for any debris and drain again. 3. If error continue to display – contact Hobart Service.
18	Fill Error – Booster Booster took too long to fill	1. Verify supply hose is not pinched or kinked. 2. Check that water is being supplied to machine. 3. Error will clear once water fills booster to setpoint within set time. 4. If error continues to display, possible fill valve malfunction – contact Hobart Service.
19	Chemical Deficiency Detergent / Rinse Aid / Sanitizer	1. Low or no chemicals. 2. Float level on bottle level sensor below working condition. 3. If no bottle level sensor present, jumpers are missing from chemical level sensor connectors.
do or	Program Interrupted Fill, wash, or delime cycle	1. Machine is in fill, wash or delime cycle. 2. Verify door is closed. 3. If cycle running, then there is a display updating delay.
22	Low Rinse Temperature	1. Rinse temperature below setpoint on 3 consecutive cycles. 2. Error will clear if rinse temperature meets or exceeds setpoint. 3. If error continues to display – contact Hobart Service
24	USB Drive Not Detected	1. USB not properly configured or incorrect directory path. 2. Contact Hobart Service.
25	Communication Error	1. Internal communication error 2. Contact Hobart Service.
FIL	Low Water Level at Start of Wash Cycle	1. Check if item(s) from previous wash cycle removed large amount of water from dishwasher. 2. Check orientation of ware to ensure water is not collected. 3. Will automatically correct after starting of the next cycle. 4. Wash tank will fill to proper level and heat to temperature and then wash cycle will resume.
30	Booster Heat Up Time Exceeded at Startup	1. Press the power button to power off and drain tank. 2. Restart as normal. 3. If error continue to display, unplug the machine from the wall. If unit is hardwired, turn circuit breaker off then back on. 4. If error continues to display, possible tripped high limit or heating element malfunction – contact Hobart Service.
31	Fill Error	1. System exceeded maximum fill time. 2. Press the power button to power off machine. 3. Verify supply hose is not pinched or kinked. 4. Check that water is being supplied to machine. 5. Restart as normal. 6. If error continues to display, possible fill valve malfunction – contact Hobart Service.

**NOTE: SWITCHING DISHWASHER OFF AND THEN ON “RESETS” THE SIGNALS.**

**\*IF ERROR CODE PERSISTS, CONTACT HOBART SERVICE:**

**1-888-4HOBART**

**centerline**  
by **HOBART**