

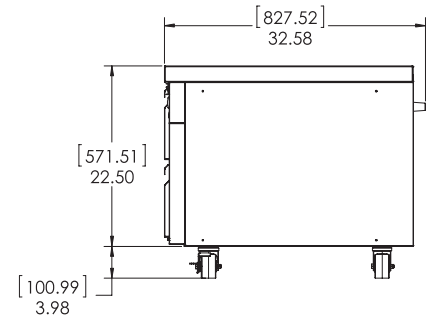

Refrigerated Chef Base

MODEL SKRCB84H/C10

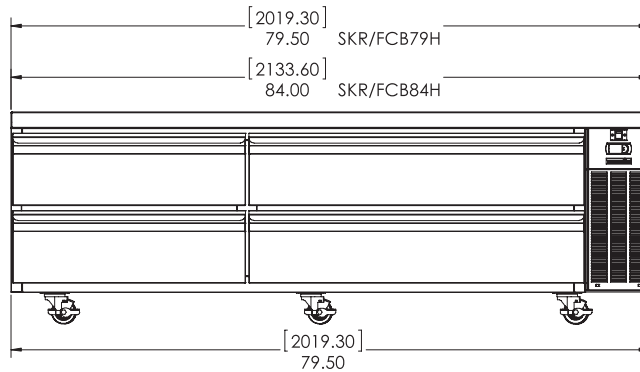
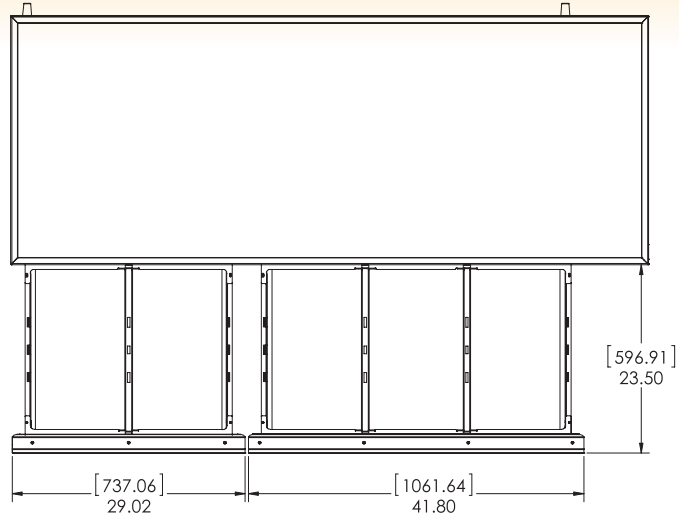

MODEL	LENGTH	DEPTH	HEIGHT	COMPRESSOR	AMPS	WEIGHT
SKRCB84H/C10	84"	32.58"	26.48"	1/4 HP	3.1	620 lbs.

- EXTERIOR** Stainless steel. Galvanized back.
- INTERIOR** Aluminum. Coved corners and finished edges for ease of cleaning.
- INSULATION** Environmentally friendly foamed-in-place polyurethane for maximum strength and durability.
- DRAWERS** Full extension drawers with drawer slides welded to 12-gauge stainless steel framework. This premier slide and framework construction promotes lateral stability while offering high dynamic load capacities and a stay-shut feature. All drawers accom modate full size 12" x 20" x 6" deep hotel pans and 6" deep fractional pans. Drawers lift out for cleaning.
- REFRIGERATION** CFC-free, 134a refrigerant, hermetically sealed, high efficiency, self contained refrigeration system.
- LISTINGS** ETL Safety (U.S. and Canada), ETL Sanitation.
- WARRANTY** One year parts and labor. Five year warranty on heavy duty drawer assemblies and compressor.



1600 Xenium Lane North
 Minneapolis, MN 55441-3787
 Phone (763) 923-2441
 Fax (763) 553-1209
 www.silverking.com



Specifications subject to change without notice.

7/2013
 © Silver King 2013
 Printed in U.S.A.