



Our main ingredient is value

NEW

6-inch extra-large patty size!!

1404, 1405, 1406

1404, 1405, 1406

4", 5" & 6" PATTY PRESS™

BENCHTOP BURGER MOLDS

HEAVY-DUTY COMMERCIAL USE

Make perfectly shaped patties every time with the Univex PattyPress™ burger mold. This sturdy, easily operated design quickly produces uniform hamburgers, crabcakes, fishcakes or veggie-burgers. Better still, even thickness ensures more uniform cooking from edge to center for a delectable result.

Simply load ground meat or mixture into the mold, then pull the ergonomically designed handle to activate the press. Presto! Another perfectly sized patty is ready in seconds.

For hefty portions, choose Model 1406, which molds up to 16 oz. into 6-inch diameter patties. Model 1405 molds up to 8 oz. into 5-inch patties. Model 1404 molds up to 5 oz. into 4-inch patties. Thickness is determined by the quantity placed in the press.

Made of polished, die-cast aluminum and stainless steel, the PattyPress is engineered for years of reliable service. For convenience in storing finished patties, an integral receptacle holds a stack of waxed paper. Your PattyPress unit comes with a supply of waxed paper dividers, and these are available in bulk from Univex.



- Replaces flimsy, awkward hand presses with a rugged, counter-top machine.
- Uniform patty size—choose 4-inch, 5-inch or 6-inch diameter model
- Uniform thickness for even cooking, better results
- Single-lever manual operation takes only seconds
- Rugged, die-cast aluminum and stainless steel construction
- Integral holder for wax paper



SINCE 1948

UNIVEX CORPORATION ■ 3 Old Rockingham Road ■ Salem, NH 03079-2140

Tel 603-893-6191 ■ Fax 603-893-1249

TOLL-FREE ORDERING FAX 1-800-356-5614

www.univexcorp.com

April 2005
Printed in USA

4", 5" & 6" PATTY PRESS™

BENCHTOP BURGER MOLDS

1404, 1405, 1406

1404, 1405, 1406

HEAVY-DUTY COMMERCIAL USE

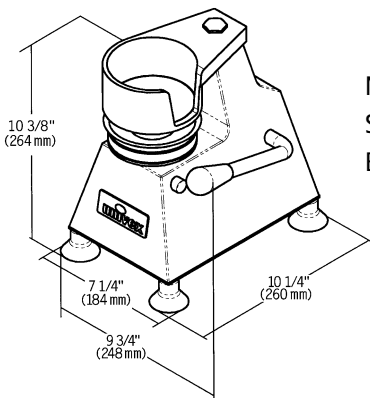
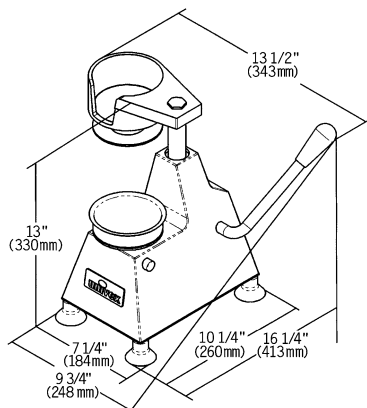

NET WEIGHT:	Models 1404 & 1405 11 lb. (5 kg)	Model 1406 12 lb. (5.4 kg)
SHIPPING WEIGHT:	13 lb. (6 kg)	14 lb. (6.4 kg)
BOX DIMENSIONS:	11" (280 mm) high	
	10" (254 mm) wide	
	10 1/2" (267 mm) deep	

SPECIFICATIONS

FINISH	Anodized aluminum and stainless steel
PATTY SIZE	MODEL 1404 4-inch (102 mm) diameter— up to 5 oz. (140g) MODEL 1405 5-inch (127 mm) diameter— up to 8 oz. (225g) MODEL 1406 6-inch (152 mm) diameter— up to 16 oz. (450g)
SUPPLIED WITH	1000 waxed paper dividers
OPTIONAL SUPPLY	Waxed paper dividers in bulk (5000 per case)

EASY OPERATION



1. Push handle all the way back. Place ball of meat or mix on bottom press plate.



2. Press release button to lower press plate into forming dish. Pull handle forward and apply light pressure.



3. Return handle to the rear. Press plate rises automatically for easy removal.

WARRANTY

The Univex PattyPress™ Burger Mold is warranted by Univex Corporation against defects in materials for a period of six months from date of delivery if delivered to a destination in the United States. The unit must be returned to Univex for warranty repairs. Contact Univex Service Department to report any warranty claim. Univex shall not be liable for any consequential, compensatory, incidental or special damages. Damages incurred in transit or from installation error, accident, alteration or misuse are not covered. Transit damages should be reported to the carrier immediately.

If the PattyPress is delivered to a country other than the United States, it is warranted by Univex's authorized distributor. Contact your distributor directly to report any warranty claims outside of the United States or Canada.



UNIVEX CORPORATION ■ 3 Old Rockingham Road ■ Salem, NH 03079-2140
Tel 603-893-6191 ■ Fax 603-893-1249
TOLL-FREE ORDERING FAX 1-800-356-5614
www.univexcorp.com

April 2005
Printed in USA