

Project _____

Item Number _____

Quantity _____

SPZ40 / SPZ50



SPZ40 / SPZ50 Pizza Spinner

Models:

- SPZ40: 15.75" (40cm) Cold system pizza spinner
- SPZ50: 19.69" (50cm) Cold system pizza spinner



Pizza Spinner

Features:

- Bench model pizza spinner
- Patented micro rolling system
- User adjustable crust thickness
- Produces repeatable results
- Is a cold system pizza spinner, meaning you are not partially cooking your dough
- Automatic start and stop
- Consistency Machine, made to take your dough ball from 0-85% of the way completed.

Standard Accessories:

- SPZ40 15.75" (40cm) ring with felt
- SPZ50 19.69" (50cm) ring with felt

Optional Accessories:

- Additional SPZ40 15.75" (40cm) ring with felt
- Additional SPZ50 19.69" (50cm) ring with felt
- Stand with wheels

Univex Corporation

The SPZ50 can not do any sizes smaller than 17" pizza's.

Warranty:

- One year, on-site parts and labor



WE RAISE THE BAR. WE SET THE STANDARD.

Pizza Spinner

SPZ40 / SPZ50

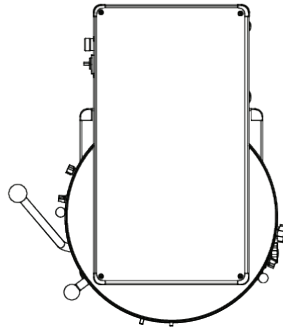

Line drawing is the SPZ50

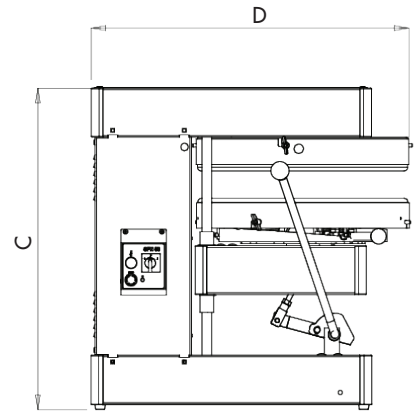
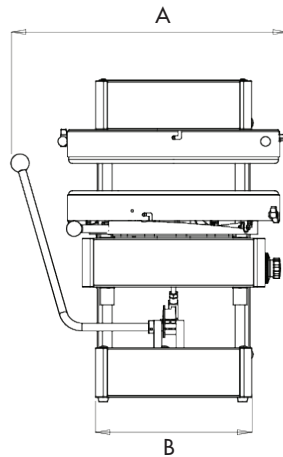

	SPZ40	SPZ50
A	22 3/8" (56.8cm)	28" (70.9cm)
B	13" (32.3cm)	15 7/8" (40.2cm)
C	30" (76.1cm)	32 5/8" (82.6cm)
D	28 3/8" (72cm)	32 1/2" (82.5cm)

Controls: Stop and start push buttons, dual levers for initial press and for crust formation.

Drive: Belt drive

NEMA #: 5-15-P

Electrical Information (60Hz)		
Model	Standard Voltage	Amps
SPZ40	115V/60Hz/1ph	5
SPZ50	115V/60Hz/1ph	7

Shipping Information			
Model	Net Weight	Shipping Weight	Overall Dimensions
SPZ40	265 lbs. (120Kg)	375 lbs. (170Kg)	46" (116.8cm) H x 33" (83.8cm) W x 39" (99.1cm) D
SPZ50	330 lbs. (150Kg)	441 lbs. (200Kg)	46" (116.8cm) H x 33" (83.8cm) W x 39" (99.1cm) D



Univex Corporation
www.Univexcorp.com

3 Old Rockingham Rd
Salem, NH 03079
United States of America

INTL TEL: (800)258-6358
TEL: (603)893-6191
INTL FAX: (800)356-5614
FAX: (603)893-1249