

**FRYERS****VULCAN****MF  
MOBILE FILTER****Model MF****SPECIFICATIONS**

Mobile filter system, Vulcan-Hart Model No. MF. Filter pan constructed of 16 gauge stainless steel. Stainless steel handle and casters provide mobility. Roll up to any fryer to drain and filter oil. 110 lbs. maximum filter capacity of shortening. 1/3 H.P. motor and pump circulates hot frying compound at the rate of 8 gallons per minute. System provided with removable stainless steel primary crumb basket and mesh screen. Flushing/Discard high temperature hose standard. Requires 120 volt, 60 Hz, 1 phase power supply.

**Overall Dimensions:**

19.91"w x 39.38"d x 20.21"h.

**Not recommended for use with solid shortening.**

**STANDARD FEATURES**

- 16 gauge stainless steel filter vessel. 110 lbs. capacity.
- Stainless steel handle and 6" casters for ease of mobility.
- 4' high temperature oil flushing/discard hose with handle.
- 1/3 H.P. motor and pump circulates hot frying compound at the rate of 8 gallons per minute.
- Removable stainless steel primary crumb basket.
- Removable stainless steel mesh screen.
- Filter pan, crumb basket, mesh screen dishwasher safe.
- 120 volt, 60 Hz, 1 phase.
- One year limited parts and labor warranty

**ACCESSORIES** (Packaged & Sold Separately)

- Micro-Filtration Filter Envelope Conversion Kit  
AFC CODE (85MF FABENV)
- Micro-Filtration Fabric Replacement Envelopes (6 Pack)  
AFC CODE (VULPACK FILTER)

**OPTIONS**

- Second year extended limited parts and labor warranty.

**VULCAN**

a division of ITW Food Equipment Group LLC

P.O. Box 696 ■ Louisville, KY 40201 ■ Toll-free: 1-800-814-2028 ■ Local: 502-778-2791 ■ Quote & Order Fax: 1-800-444-0602



**MF**  
**MOBILE FILTER**

**INSTALLATION INSTRUCTIONS**

1. The use of diatomaceous filtering compound is recommended for thorough cleansing of the shortening. However, it is not required for filtration with this unit.
2. This appliance is manufactured for commercial installation only and is not intended for home use.

**SERVICE CONNECTIONS:**

120 volt, 60 Hz, 1 phase power supply. Requires a NEMA 5-15P, 14 guage oil and grease rated (not supplied with mobile filter).

**NOTE:** In line with its policy to continually improve its product, Vulcan reserves the right to change materials and specifications without notice.

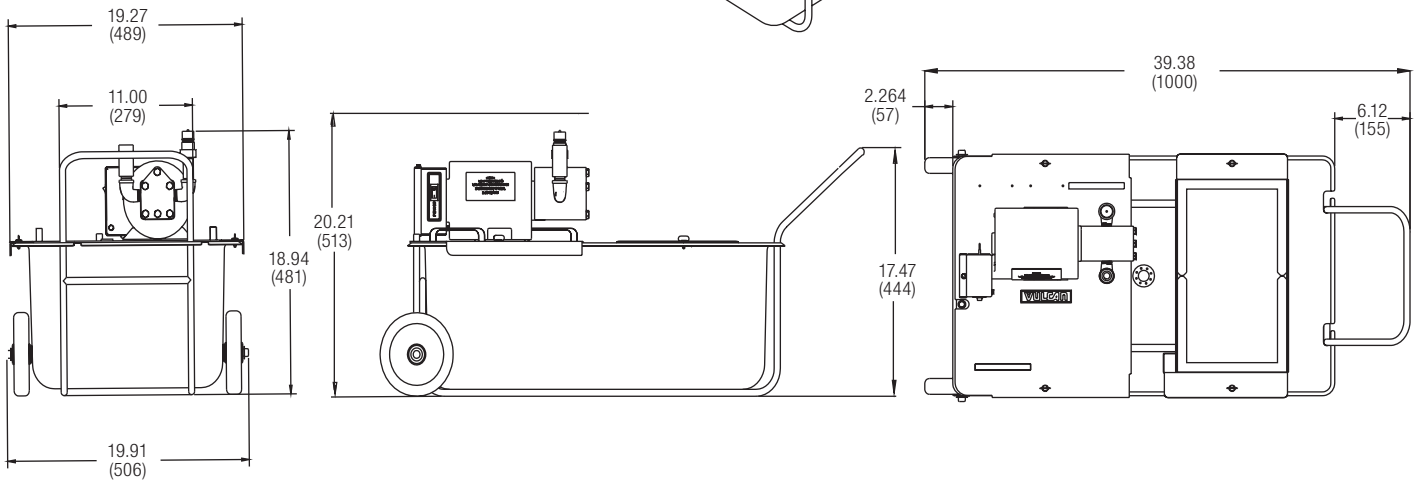
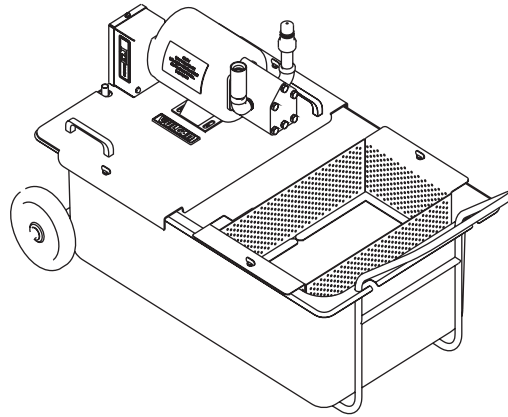

Model	Motor	Electric / Amps	Pump Capacity	Filter Area	Approx. Shipping Weight
MF	1/3 HP 1750 RPM	115V 5.0A	8 gal/min.	270 sq. in	86 lbs. (kg)

This appliance is manufactured for commercial use only and is not intended for home use.



a division of ITW Food Equipment Group LLC

P.O. Box 696 ■ Louisville, KY 40201 ■ Toll-free: 1-800-814-2028 ■ Local: 502-778-2791 ■ Quote & Order Fax: 1-800-444-0602