

VULCAN

CATALOG OF REPLACEMENT PARTS

1GR SERIES FRYER STAND ALONE

<i>MODEL</i>	<i>ML NUMBER</i>
1GR35M	ML-136407
1GR45M	ML-136408
1GR65M	ML-136409
1GR85M	ML-136410
1GR45D	ML-136411
1GR65D	ML-136412
1GR85D	ML-136413
1GR45C	ML-136414
1GR65C	ML-136415
1GR85C	ML-136416
1GR45DF	ML-136788
1GR85DF	ML-136790
1GR45CF	ML-136791
1GR85CF	ML-136793



For additional information on Vulcan-Hart Company or to locate an authorized parts and service provider in your area, visit our website at www.vulcanequipment.com

TABLE OF CONTENTS

5	CONTROL PANEL (NCC)
7	POWER SUPPLY BOX
9	BODY UNIT (1GRC & 1GRD SERIES)
11	BODY UNIT (1GRM)
13	BODY UNIT (FRYERS WITH FILTER)
15	BURNER COMPONENTS (1GRC & 1GRD SERIES)
17	BURNER COMPONENTS (1GRM SERIES)
18	GAS VALVE (1GRC & 1GRD SERIES) (PREVIOUS CONSTRUCTION)
19	GAS VALVE (1GRC & 1GRD SERIES) (CURRENT CONSTRUCTION)
20	GAS VALVE (1GRM SERIES) (PREVIOUS CONSTRUCTION)
21	GAS VALVE (1GRM SERIES) (CURRENT CONSTRUCTION)
23	TANK AND DRAIN ASSEMBLY
25	OIL RETURN (1GR45CF/DF & 1GR85CF/DF)
27	FILTER ASSEMBLY

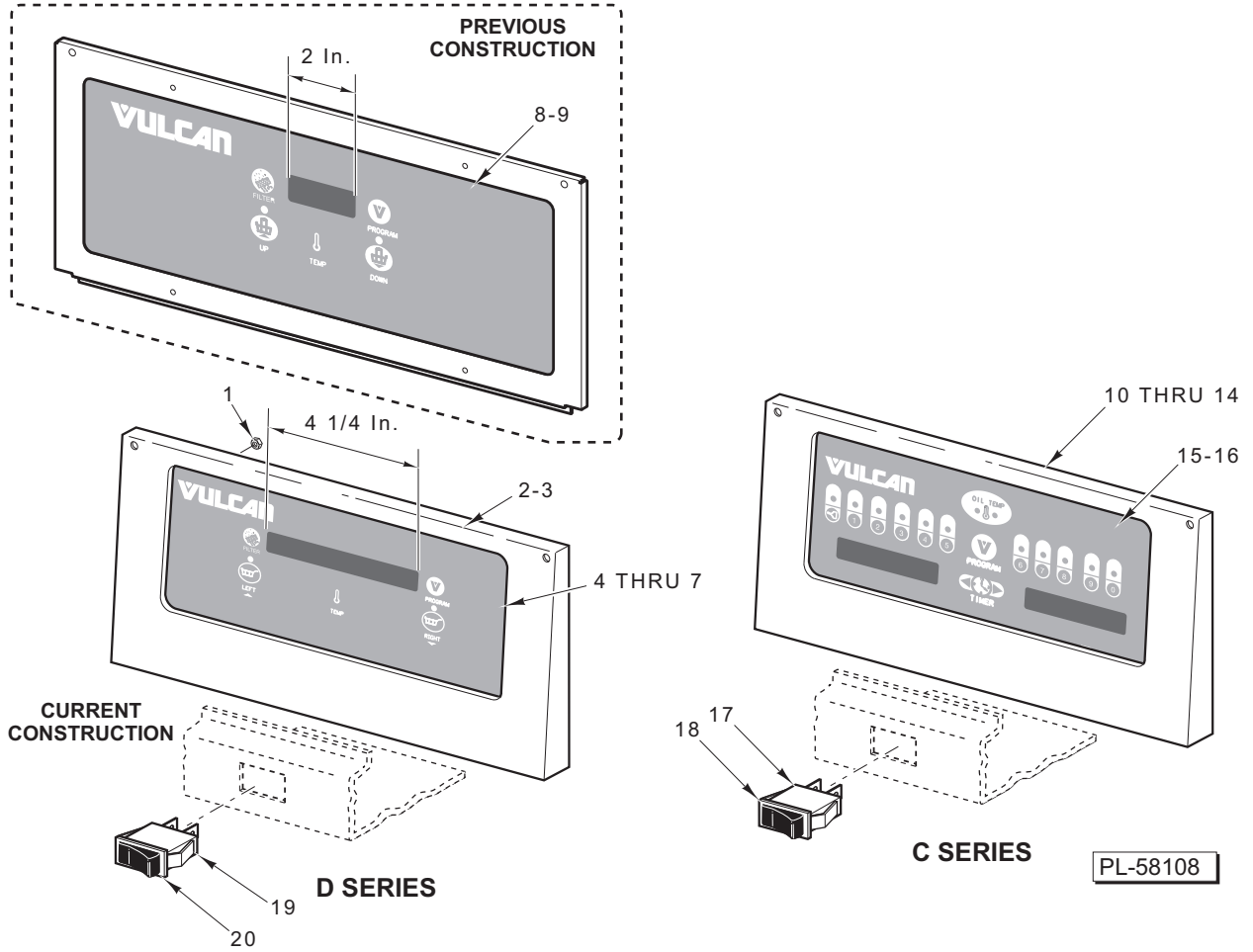

CONTROL PANEL (NCC)

CONTROL PANEL (NCC)

ILLUS.	PART NO.	NAME OF PART	AMT.
	PL-58108		
1	NS-046-89	Nut Assy. 6-32 Hex	4
2	00-426815-000G1	Plate Assy. – Mounting (1GR45C, 1GR45D, & 1GR45CF).....	1
3	00-426815-000G2	Plate Assy. – Mounting (1GR65/85C, 1GR65/85D, & 1GR85CF/DF).....	1
4	00-497745-00001	Overlay – Vulcan (Filter Button).....	1
5	00-497745-00003	Overlay – Vulcan (Boil Button).....	1
6	00-913086-00004	Control Assy. – Solid State (Filter Button) (Incls. Item 4).....	1
7	00-913086-00003	Control Assy. – Solid State (Boil Button) (Incls. Item 5).....	1
8	00-497421-00001	Overlay – Control Panel (Boil Button).....	1
9	00-427820-00001	Overlay – Control Panel (Filter Button).....	1
10	00-913086-00002	Computer Cooking Assy. (Filter Button) (Incls. Item 15).....	1
11	00-913086-00001	Computer Cooking Assy. (Boil Button) (Incls. Item 16).....	1
12	00-426815-000G1	Plate Assy. – Mounting (1GR45C, 1GR45D, & 1GR45CF).....	1
13	00-426815-000G2	Plate Assy. – Mounting (1GR65/85C, 1GR65/85D, & 1GR85CF/DF).....	1
14	NS-046-89	Nut Assy. 6-32 Hex	4
15	00-426732-00001	Overlay – Control Panel (Filter Button).....	1
16	00-497422-00001	Overlay – Control Panel (Boil Button).....	1
17	00-427755-000G1	Switch Assy. – Power.....	1
18	00-428906-00001	Overlay – Power	1
19	00-427755-000G1	Switch Assy. – Power.....	1
20	00-428906-00001	Overlay – Power	1

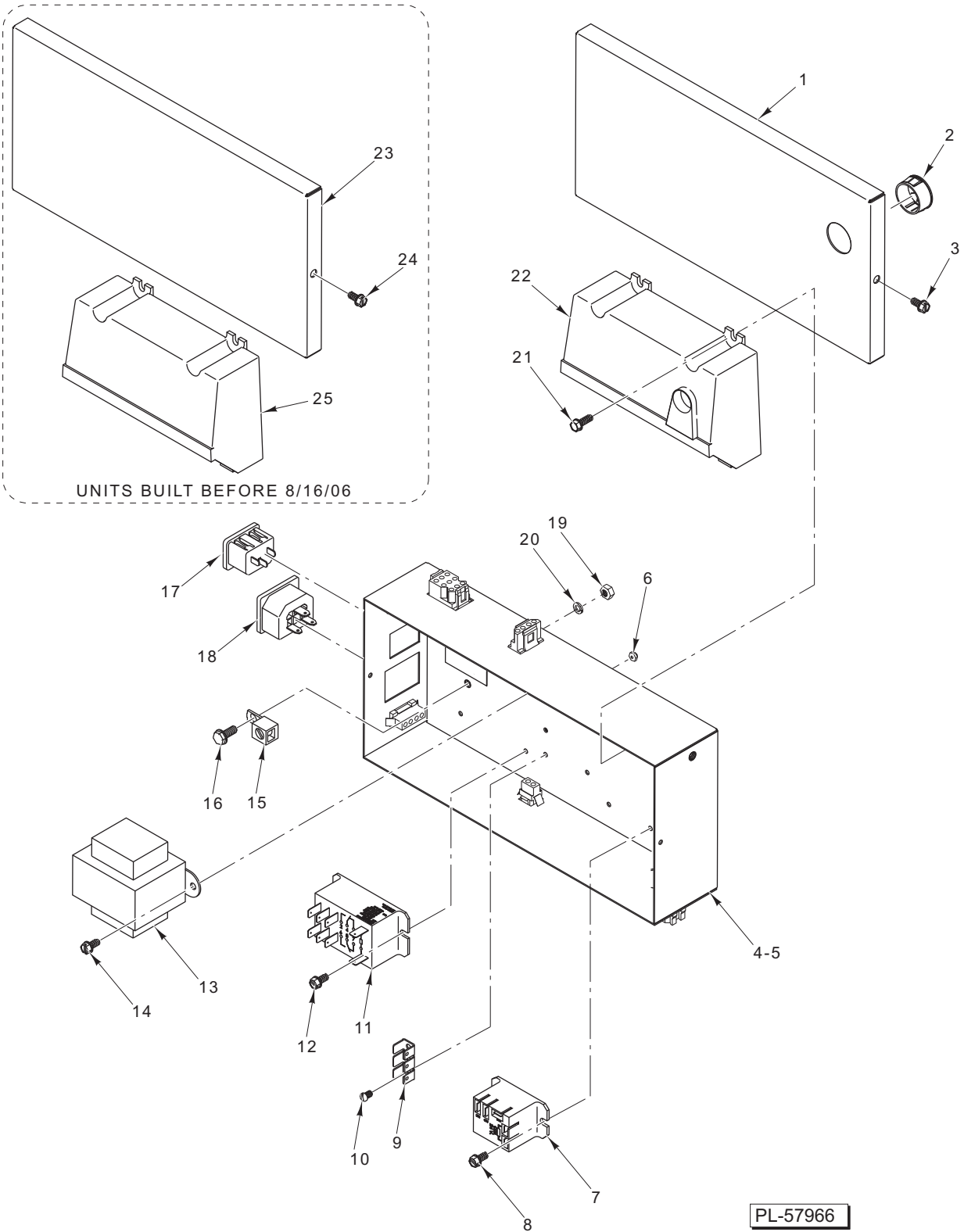

POWER SUPPLY BOX

POWER SUPPLY BOX

ILLUS.	PART NO.	NAME OF PART	AMT.
PL-57966			
1	00-428684-00002	Lid – Power Supply (Machines Built After 8/16/06).....	1
2	FE-024-24	Bushing – Electrical Snap.....	1
3	SD-036-03	Self-Tapping Screw 8-18 x 3/8 Hex Washer Hd., Type AB.....	2
4	00-428716-000G1	Box – Power Supply (Filter).....	1
5	00-428716-000G2	Box – Power Supply (Non-Filter).....	1
6	NS-047-32	Lock Nut 4-40 Hex.....	2
7	00-497125-00001	Relay (S.P.D.T., 24 VAC).....	1
8	SD-036-03	Self-Tapping Screw 8-18 x 3/8 Hex Washer Hd., Type AB.....	2
9	00-419317	Lug – Terminal.....	1
10	SC-060-23	Mach. Screw 4-40 x 1/4 Slotted Rd. Hd.	2
11	00-428864-00001	Relay.....	1
12	SD-036-03	Self-Tapping Screw 8-18 x 3/8 Hex Washer Hd., Type AB.....	2
13	00-411500-00012	Transformer (120 V.-24 V., 40 Amp.).....	1
14	SD-036-03	Self-Tapping Screw 8-18 x 3/8 Hex Washer Hd., Type AB.....	2
15	00-417856-00001	Lug – Ground.....	1
16	SD-032-07	Self-Tapping Screw 10-24 x 1/2 Hex Washer Hd., Type TT.....	1
17	00-419973-000G1	Receptacle – Male Power.....	1
18	00-419973-000G2	Receptacle – Female Power.....	1
19	NS-044-09	Nut Assy. 10-24 Hex KEPS.....	1
20	WL-004-40	Lockwasher #10 Helical.....	1
21	SD-037-49	Self-Tapping Screw 8-18 x 1/2 Hex Washer Hd., Type AB.....	4
22	00-857207-00001	Module – Ignition (Machines Built After 8/16/06).....	1
23	00-428684-00001	Lid – Power Supply Box (Machines Built On Or Before 8/16/06).....	1
24	SD-036-03	Self-Tapping Screw 8-18 x 3/8 Hex Washer Hd., Type AB.....	2
*25	-	Module – Ignition (Machines With Electronic Ignition) (Machines Built On Or Before 8/16/06).....	1
	00-428685-000G2	Box – Power Supply (With Filtration) (Incls. Items 1 thru 4 & 6 thru 24).....	1
	00-428685-000G5	Box – Power Supply (Without Filtration) (Incls. Items 1, 2, 3, 5, 6, 8, 9, 10, 12 thru 17, & 19 thru 24).....	1

* Order items 1, 2, & 22 for replacement.

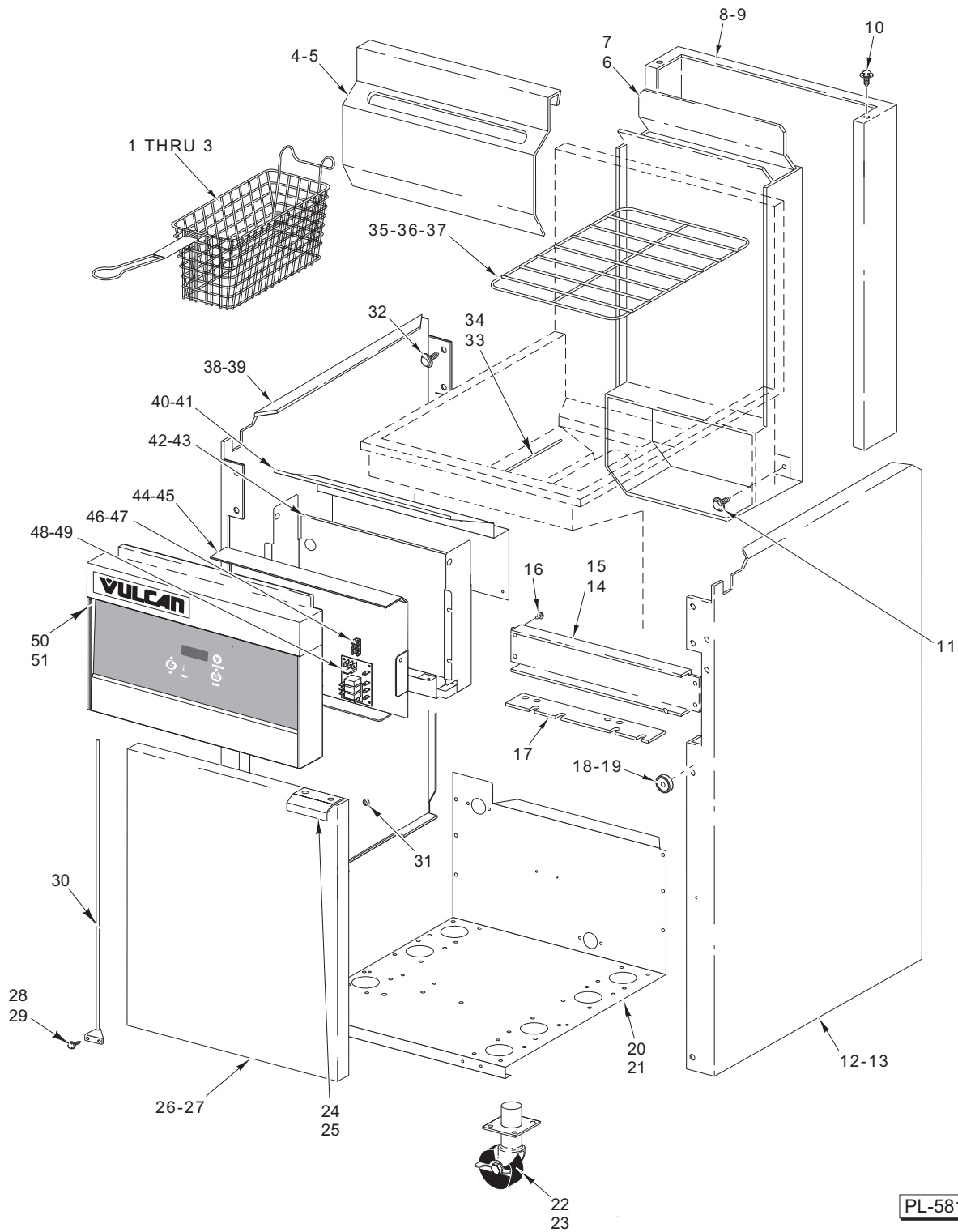

BODY UNIT (1GRC & 1GRD SERIES)

BODY UNIT (1GRC & 1GRD SERIES)

ILLUS. PL-58109	PART NO.	NAME OF PART	AMT.
1	00-499223-00001	Basket – Twin (1GR45C & 1GR45D).....	2
2	00-499223-00002	Basket – Twin (1GR65C & 1GR65D).....	2
3	00-499223-00003	Basket – Twin (1GR85C & 1GR85D).....	1
4	00-417056-00002	Hanger – Basket (1GR45C & 1GR45D).....	2
5	00-418321-00002	Hanger – Basket (1GR65C/D & 1GR85C/D).....	2
6	00-418201-000G2	Flue Assy. (4 Tube) (1GR45C & 1GR45D).....	1
7	00-418205-000G2	Flue Assy. (5 Tube) (1GR65C/D & 1GR85C/D).....	1
8	00-416959-00002	Wrap – Flue (3 Tube or 4 Tube) (1GR45C & 1GR45D).....	1
9	00-418336-00002	Wrap – Flue (5 Tube) (SST) (1GR65C/D & 1GR85C/D).....	1
10	SD-032-07	Self-Tapping Screw 10-24 x 1/2 Hex Washer Hd., Type TT.....	2
11	SD-037-70	Self-Tapping Screw 1/4-20 x 1/2 Hex Washer Hd., Type TT.....	4
12	00-419648-00002	Body – RH Side (SST) (1GR45/65C & 1GR45/65D).....	1
13	00-420596-00004	Body – RH Side (SST) (1GR85C & 1GR85D).....	1
14	00-428699-00001	Brace – Rear (1GR45C & 1GR45D).....	1
15	00-428749-00001	Brace – Rear (1GR65C/D & 1GR85C/D).....	1
16	SD-032-07	Self-Tapping Screw 10-24 x 1/2 Hex Washer Hd., Type TT.....	2
17	00-428688-00001	Bracket – Power Supply Mounting.....	1
18	RS-033-04	Rivet – Pop.....	1
19	00-497296-000G2	Magnet Assy.....	1
20	00-497428-00001	Body – Bottom (1GR45C & 1GR45D).....	1
21	00-497428-00003	Body – Bottom (1GR65C/D & 1GR85C/D).....	1
22	00-421893-00001	Mount Plate – Caster.....	AR
23	00-421893-00002	Caster (4 In.) (No Brake).....	AR
24	00-419653	Handle – Door.....	1
25	RS-033-09	Rivet – Pop (0.187).....	2
26	00-499487-000G1	Door Assy. (LH) (1GR45C & 1GR45D).....	1
27	00-499487-000G5	Door Assy. (LH) (1GR65C/D & 1GR85C/D).....	1
28	SD-032-07	Self-Tapping Screw 10-24 x 1/2 Hex Washer Hd., Type TT.....	2
29	NS-044-09	Nut Assy. 10-24 Hex KEPS.....	2
30	00-428023-000G2	Hinge Assy.....	1
31	00-420769-00001	Bumper – Rubber.....	1
32	SD-036-03	Self-Tapping Screw 8-18 x 3/8 Slotted Hex Washer Hd., Type AB.....	AR
33	00-419592-00001	Clip – Thermistor Probe.....	1
34	00-419379-00001	Probe – Thermistor.....	1
35	00-427883-00002	Screen – Basket Support (1GR45C & 1GR45D).....	1
36	00-427883-00003	Screen – Basket Support (1GR65C & 1GR65D).....	1
37	00-427883-00004	Screen – Basket Support (1GR85C & 1GR85D).....	1
38	00-419648-00001	Body – LH Side (SST) (1GR45/65C & 1GR45/65D).....	1
39	00-420596-00003	Body – LH Side (SST) (1GR85C & 1GR85D).....	1
40	00-428548-00001	Heat Shield (1GR45C & 1GR45D).....	1
41	00-428548-00002	Heat Shield (1GR65/85C & 1GR65/85D).....	1
42	00-428542-00001	Deflector Assy. (1GR45C & 1GR45D).....	1
43	00-428689-00001	Deflector Assy. (1GR65C/D & 1GR85C/D).....	1
44	00-428541-00001	Plate – Control Mounting (1GR45C & 1GR45D).....	1
45	00-428690-00001	Plate – Control Mounting (1GR65C/D & 1GR85C/D).....	1
46	00-419317	Terminal – Stationary.....	1
47	SC-060-23	Mach. Screw 4-40 x 1/4 Slotted Rd. Hd.....	2
48	00-427759-00001	Control – Interface.....	1
49	SD-024-40	Self-Tapping Screw 6-32 x 5/8 Phil. Pan Hd., Type TT.....	4
50	00-426806-000G1	Frame – Front Assy. (1GR45C & 1GR45D).....	1
51	00-426806-000G4	Frame – Front Assy. (1GR65C/D & 1GR85C/D).....	1

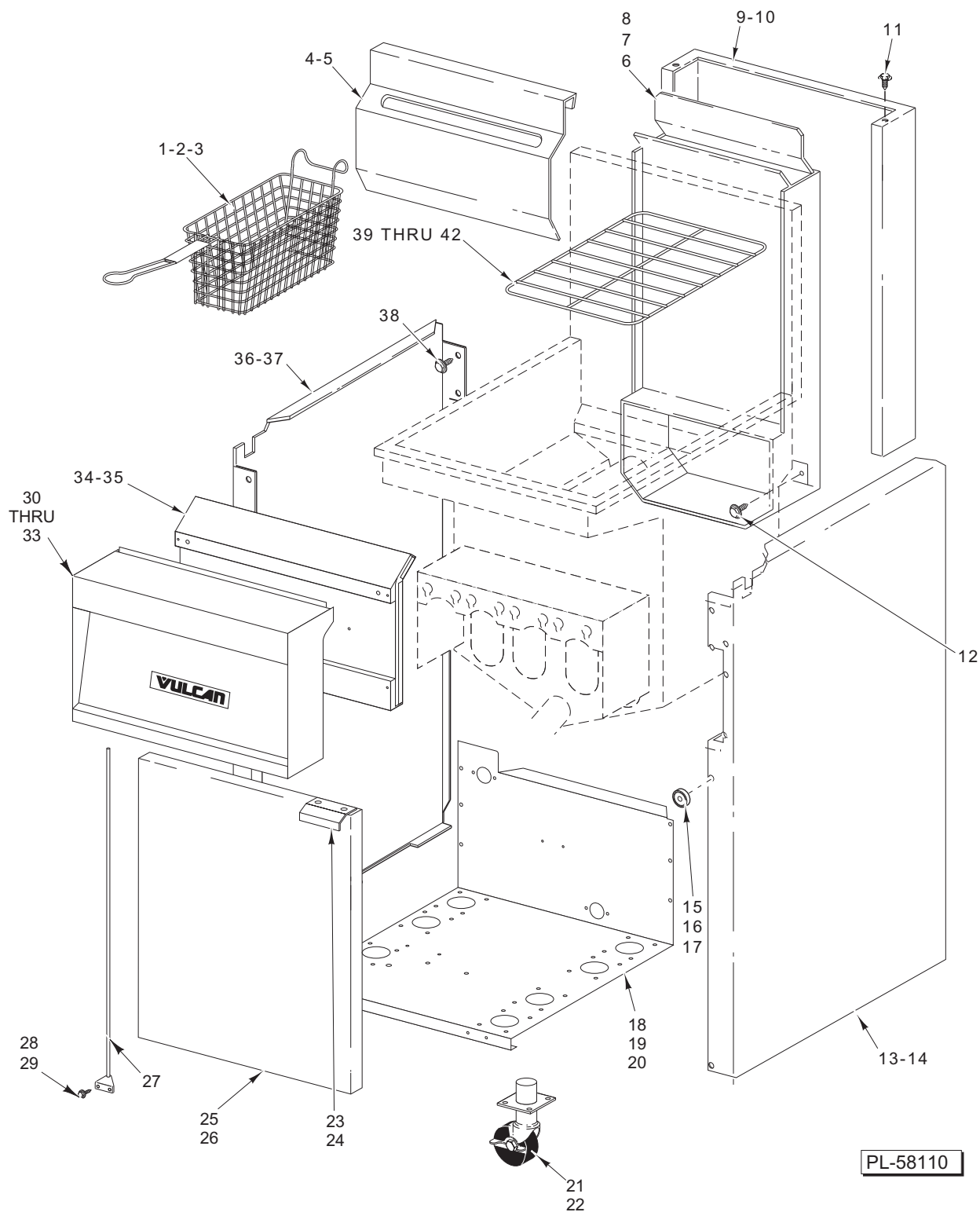

BODY UNIT (1GRM)

BODY UNIT (1GRM)

ILLUS. PL-58110	PART NO.	NAME OF PART	AMT.
1	00-499223-00001	Basket – Twin (1GR35M & 1GR45M).....	2
2	00-499223-00002	Basket – Twin (1GR65M).....	2
3	00-499223-00003	Basket – Twin (1GR85M).....	1
4	00-417056-00002	Hanger – Basket (1GR35M & 1GR45M).....	2
5	00-418321-00002	Hanger – Basket (1GR65M & 1GR85M).....	2
6	00-416994-000G2	Flue Assy. (3 Tube) (1GR35M).....	1
7	00-418201-000G2	Flue Assy. (4 Tube) (1GR45M).....	1
8	00-418205-000G2	Flue Assy. (5 Tube) (1GR65M & 1GR85M).....	1
9	00-416959-00002	Wrap – Flue (3 Tube or 4 Tube) (1GR35M & 1GR45M).....	1
10	00-418336-00002	Wrap – Flue (5 Tube) (SST) (1GR65M & 1GR85M).....	1
11	SD-032-07	Self-Tapping Screw 10-24 x 1/2 Hex Washer Hd., Type TT.....	2
12	SD-037-70	Self-Tapping Screw 1/4-20 x 1/2 Hex Washer Hd., Type TT.....	4
13	00-419648-00002	Body – RH Side (SST) (1GR35M, 1GR45M, & 1GR65M).....	1
14	00-420596-00004	Body – RH Side (SST) (1GR85M).....	1
15	00-497296-00001	Magnet – Door.....	1
16	RS-033-04	Rivet – Pop.....	1
17	00-497296-000G2	Magnet Assy.....	2
18	00-497428-00001	Body – Bottom (1GR35M & 1GR45M).....	1
19	00-497428-00003	Body – Bottom (1GR65M).....	1
20	00-497428-00004	Body – Bottom (1GR85M).....	1
21	00-421893-00001	Mount Plate – Caster.....	AR
22	00-421893-00002	Caster (4 In.) (No Brake).....	AR
23	00-419653	Handle – Door.....	1
24	RS-033-09	Rivet – Pop (0.187).....	2
25	00-499487-000G1	Door Assy. (LH) (1GR35M & 1GR45M).....	1
26	00-499487-000G5	Door Assy. (LH) (1GR65M & 1GR85M).....	1
27	00-428023-000G2	Hinge Assy.....	1
28	SD-032-07	Self-Tapping Screw 10-24 x 1/2 Hex Washer Hd., Type TT.....	2
29	NS-044-09	Nut Assy. 10-24 Hex KEPS.....	2
30	00-428116-000G1	Frame – Front Assy. (1GR35M & 1GR45M).....	1
31	00-428116-000G2	Frame – Front Assy. (1GR65M & 1GR85M).....	1
32	00-417700-00002	Nameplate (6 In.).....	1
33	NS-047-79	Lock Nut 3/16.....	2
34	00-418379-000G1	Heat Shield (1GR35M & 1GR45M).....	1
35	00-418324-000G1	Heat Shield (1GR65M & 1GR85M).....	1
36	00-419648-00001	Body – LH Side (SST) (1GR35M, 1GR45M, & 1GR65M).....	1
37	00-420596-00003	Body – LH Side (SST) (1GR85M).....	1
38	SD-036-03	Self-Tapping Screw 8-18 x 3/8 Slotted Hex Washer Hd., Type AB.....	AR
39	00-427883-00001	Screen – Basket Support (1GR35M).....	1
40	00-427883-00002	Screen – Basket Support (1GR45M).....	1
41	00-427883-00003	Screen – Basket Support (1GR65M).....	1
42	00-427883-00004	Screen – Basket Support (1GR85M).....	1

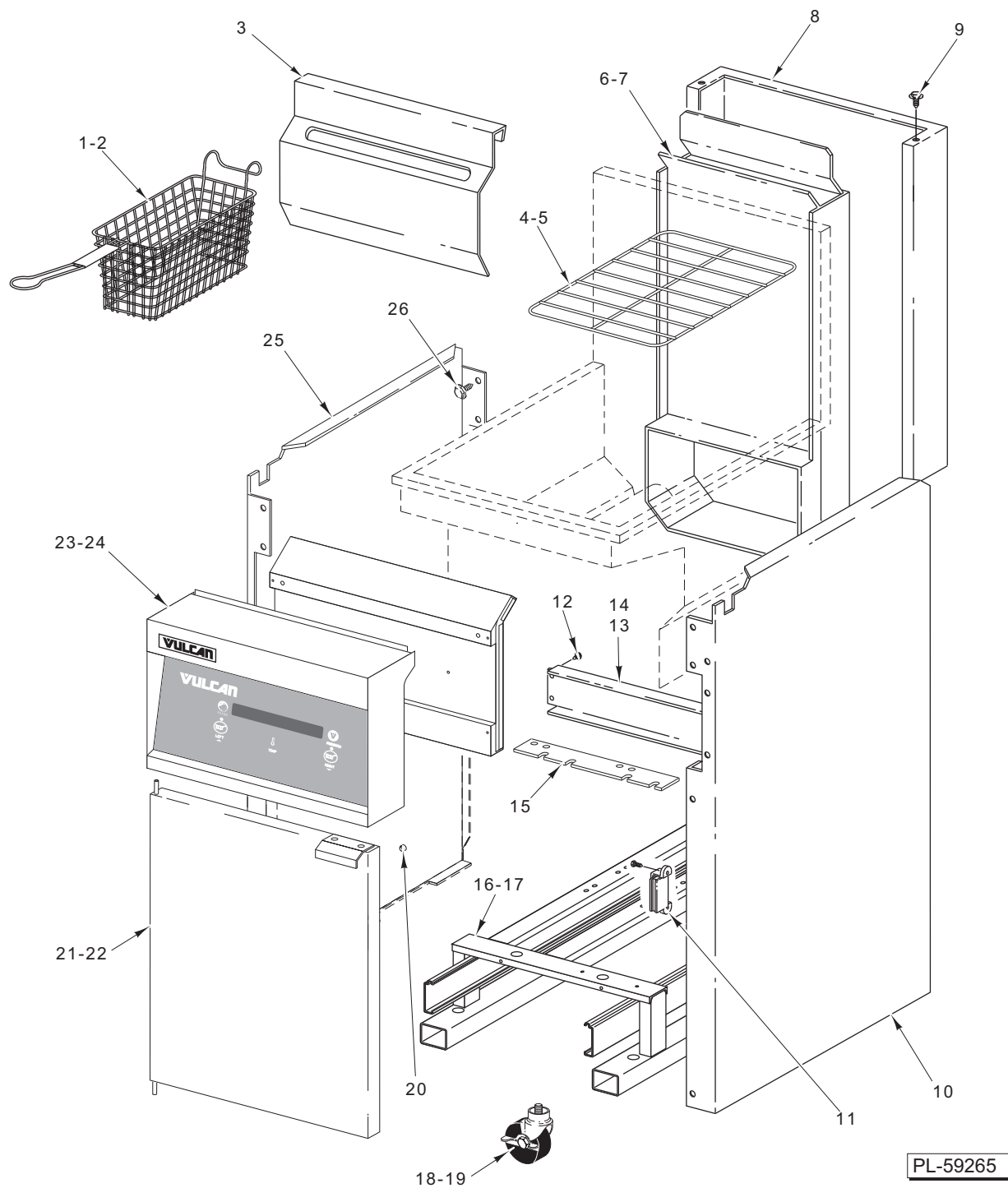

BODY UNIT (FRYERS WITH FILTER)

BODY UNIT (FRYERS WITH FILTER)

ILLUS. PL-59265	PART NO.	NAME OF PART	AMT.
1	00-499223-00003	Basket – Twin (1GR85CF/DF).....	AR
2	00-499223-00001	Basket – Twin (1GR45CF/DF).....	1
3	00-418321-00002	Hanger – Basket (1GR85CF/DF).....	1
4	00-427883-00004	Screen – Basket Support (1GR85CF/DF).....	1
5	00-427883-00002	Screen – Basket Support (1GR45CF/DF).....	1
6	00-418205-000G2	Flue Assy. (1GR85CF/DF).....	1
7	00-418201-000G3	Flue Assy. (1GR45CF/DF).....	1
8	00-418336-00002	Wrap – Flue (SST) (1GR85CF/DF).....	1
9	SD-032-07	Self-Tapping Screw 10-24 x 1/2 Hex Washer Hd., Type TT.....	AR
10	00-419777-00004	Body – RH Side (SST).....	1
11	00-497296-000G2	Magnet – Door.....	1
12	SD-032-07	Self-Tapping Screw 10-24 x 1/2 Hex Washer Hd., Type TT.....	AR
13	00-428699-00002	Brace – Rear (1GR45CF/DF).....	1
14	00-428749-00002	Bracket – Rear Support (1GR85CF/DF).....	1
15	00-428688-00001	Bracket – Power Supply Mounting.....	1
16	00-956906-000G1	Base Assy. – Frame (1GR45CF/DF).....	1
17	00-956906-000G3	Base Assy. – Frame (1GR85CF/DF).....	1
18	00-418907-00001	Caster – Adjustable (Swivel).....	2
19	00-418907-00003	Caster – Plate Mount (4 In.).....	2
20	00-420769-00001	Bumper – Rubber.....	1
21	00-499487-000G7	Door Assy. – With Hinge (LH) (1GR85CF/DF).....	1
22	00-499487-000G3	Door Assy. – With Hinge (LH) (1GR45CF/DF).....	1
23	00-426806-000G1	Frame – Front Assy. (1GR45CF/DF).....	AR
24	00-426806-000G4	Frame – Front Assy. (GR85CF/DF).....	1
25	00-419777-00003	Body – LH Side (SST).....	1
26	SD-037-70	Self-Tapping Screw 1/4-20 x 1/2 Hex Washer Hd., Type AB.....	AR

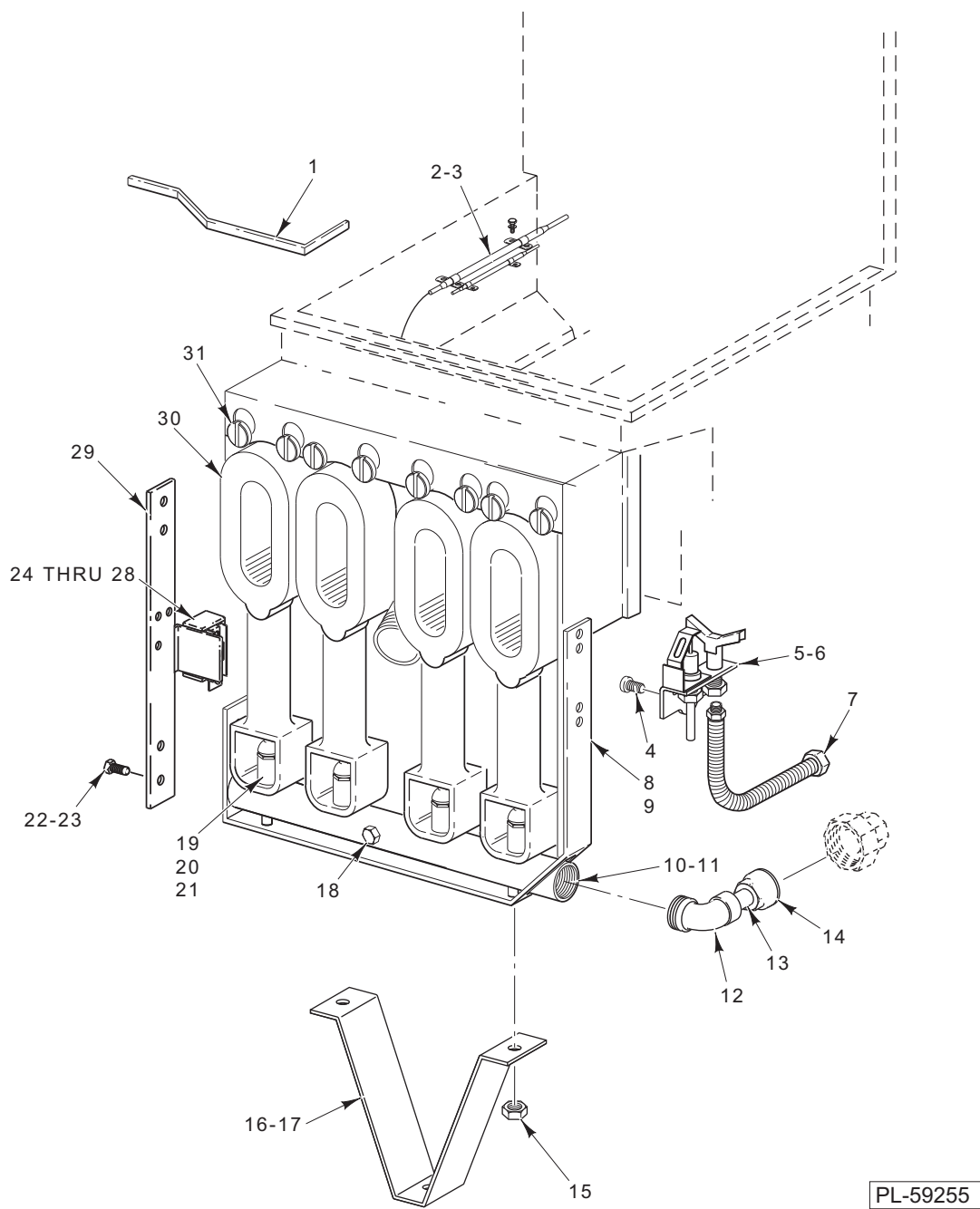

PL-59255

BURNER COMPONENTS (1GRC & 1GRD SERIES)

BURNER COMPONENTS (1GRC & 1GRD SERIES)

ILLUS. PL-59255	PART NO.	NAME OF PART	AMT.
1	00-409300-00005	Rod – Clean-Out.....	1
2	00-417522-00003	Clip – Capillary.....	4
3	SD-035-02	Self-Tapping Screw 8-18 x 3/8 Hex Washer Hd., Type AB.....	4
4	SC-018-32	Mach. Screw 8-32 x 3/8 Pan Hd.....	2
5	00-419316-00001	Pilot (NAT Gas) (Electronic Ignition).....	1
6	00-419316-00002	Pilot (LP Gas) (Electronic Ignition).....	1
7	00-426505-00023	Tube – Flex 1/4 O.D. x 23 In. Lg.	1
8	00-418211-00001	Hanger – Manifold (4 Tube).....	1
9	00-418317-00001	Hanger – Manifold (5 Tube).....	1
10	00-418212-00001	Manifold – Burner (4 Tube).....	1
11	00-418318-00001	Manifold – Burner (5 Tube).....	1
12	FP-086-74	Elbow – Pipe 1/2 x 90 Deg.	1
13	FP-059-01	Pipe 1/2 x 1 3/4 TBE	1
14	FP-022-11	Union – Pipe	1
15	NS-047-72	Lock Nut 1/4-20	2
16	00-420561-00001	Bracket – Support (1GR45C & 1GR45D)	1
17	00-420562-00001	Bracket – Support (1GR65/85C & 1GR65/85D)	1
18	FP-085-53	Pipe Plug 1/8	1
19	00-010901-00039	Orifice – Spud (NAT Gas) (Sea Level – 2000 Ft.).....	AR
20	00-010901-00052	Orifice – Spud (LP Gas) (Sea Level – 3499 Ft.).....	AR
21	00-410695-00001	Extension – Orifice.....	AR
22	SD-037-70	Self-Tapping Screw 1/4-20 x 1/2 Hex Washer Hd., Type TT.....	AR
23	NS-046-52	Nut 1/4-20 Hex	AR
24	00-419548	Bracket – Hi-Limit	1
25	SD-037-70	Self-Tapping Screw 1/4-20 x 1/2 Hex Washer Hd., Type AB.....	4
26	NS-046-52	Nut 1/4-20 Hex	4
27	SD-036-80	Self-Tapping Screw 8-32 x 3/8 Hex Washer Hd., Type TT	2
28	00-410840-00002	Box – Control Hi-Limit With Stuffing	1
29	00-417714-00001	Extension – Hanger	1
30	00-410681-00001	Burner	AR
31	00-428035-00001	Bolt – Shoulder	AR
	00-427953-00001	Bracket – Tank To Pilot	1
	00-427952-00001	Bracket – Pilot Mounting.....	1
	SC-027-55	Mach. Screw 10-32 x 1/4 Slotted Rd. Hd. (Brass).....	2
	00-419359	Cable – Spark Ignitor (36 In.).....	1

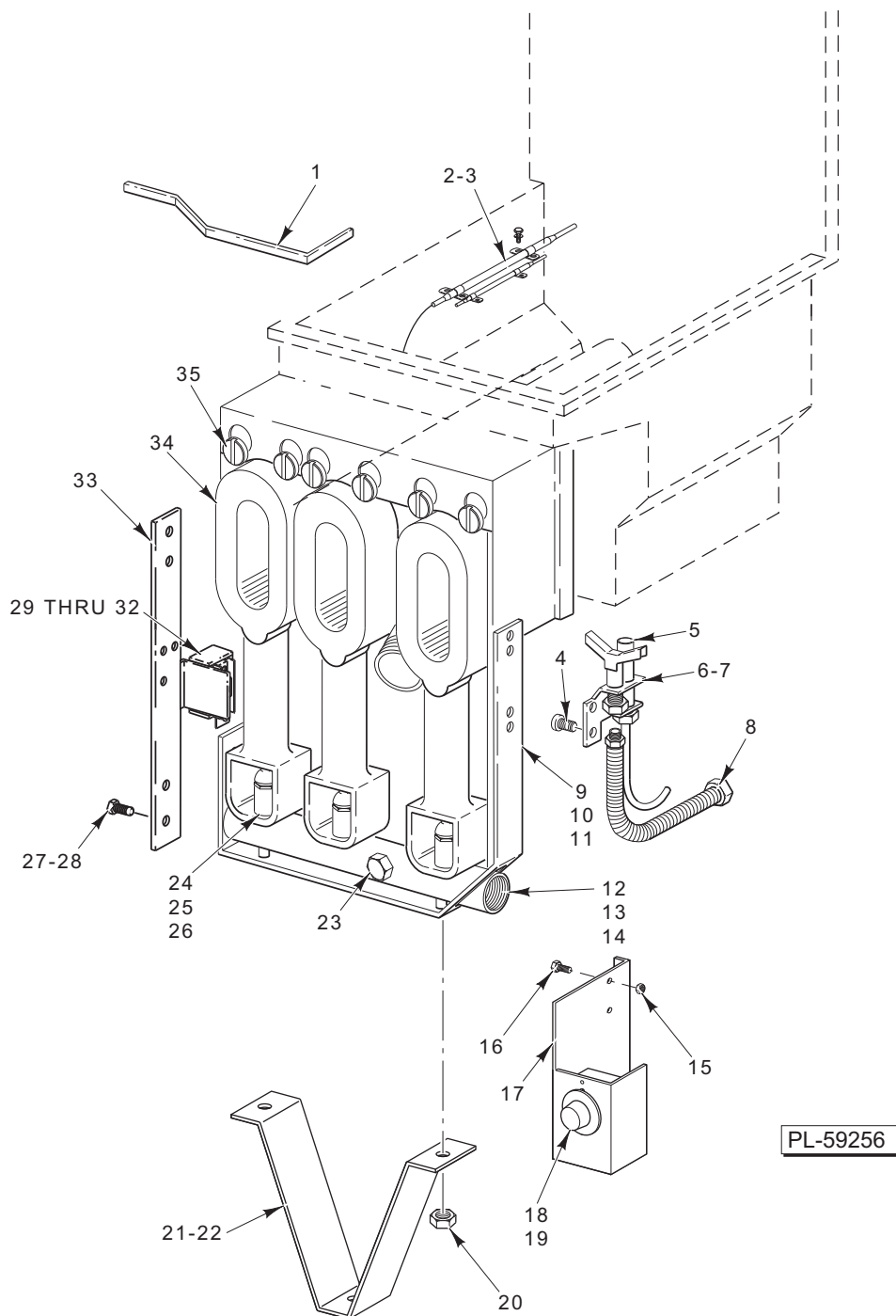

BURNER COMPONENTS (1GRM SERIES)

BURNER COMPONENTS (1GRM SERIES)

ILLUS. PL-59256	PART NO.	NAME OF PART	AMT.
1	00-409300-00005	Rod – Clean-Out.....	1
2	00-417522-00003	Clip – Capillary.....	4
3	SD-035-02	Self-Tapping Screw 8-18 x ³ / ₈ Hex Washer Hd., Type AB.....	4
4	SC-018-32	Mach. Screw 8-32 x ³ / ₈ Pan Hd.....	2
5	00-410839-00004	Thermopile – Millivolt (500 MV).....	2
6	00-412212-00007	Pilot (NAT Gas).....	1
7	00-412212-00002	Pilot (LP Gas).....	1
8	00-426505-00023	Tube – Flex ¹ / ₄ O.D. x 23 In. Lg.	1
9	00-418208-00001	Hanger – Manifold (1GR35M).....	1
10	00-418211-00001	Hanger – Manifold (1GR45M).....	1
11	00-418317-00001	Hanger – Manifold (1GR65/85M).....	1
12	00-418209-00001	Manifold – Burner (1GR35M).....	1
13	00-418212-00001	Manifold – Burner (1GR45M).....	1
14	00-418318-00001	Manifold – Burner (1GR65/85M).....	1
15	NS-046-52	Nut ¹ / ₄ -20 Hex.....	6
16	SD-037-70	Self-Tapping Screw ¹ / ₄ -20 x ¹ / ₂ Hex Washer Hd., Type TT.....	2
17	00-497089-00001	Bracket – Control.....	1
18	00-408659-00005	Knob – Thermostat.....	1
19	00-411506-00013	Thermostat – Reed.....	1
20	NS-047-72	Lock Nut ¹ / ₄ -20.....	2
21	00-420561-00001	Bracket – Support (1GR35/45M).....	1
22	00-420562-00001	Bracket – Support (1GR65/85M).....	1
23	FP-085-53	Pipe Plug ¹ / ₈	1
24	00-010901-00039	Orifice – Spud (NAT Gas) (Sea Level – 2000 Ft.).....	AR
25	00-010901-00052	Orifice – Spud (LP Gas) (Sea Level – 3499 Ft.).....	AR
26	00-410695-00001	Extension – Orifice.....	AR
27	SD-015-24	Self-Tapping Screw ¹ / ₄ -20 x ¹ / ₂ Hex Washer Hd., Type TT.....	AR
28	NS-044-14	Nut – ¹ / ₄ -20 Hex KEPS.....	AR
29	SD-037-70	Self-Tapping Screw ¹ / ₄ -20 x ¹ / ₂ Hex Washer Hd., Type AB.....	4
30	NS-046-52	Nut – ¹ / ₄ -20 Hex KEPS.....	4
31	SD-036-80	Self-Tapping Screw 8-32 x ³ / ₈ Hex Washer Hd., Type TT.....	2
32	00-419840-00002	Box – Control Hi-Limit With Stuffing.....	1
33	00-417714-00001	Extension – Hanger.....	1
34	00-410681-00001	Burner.....	AR
35	00-428035-00001	Bolt – Shoulder.....	AR

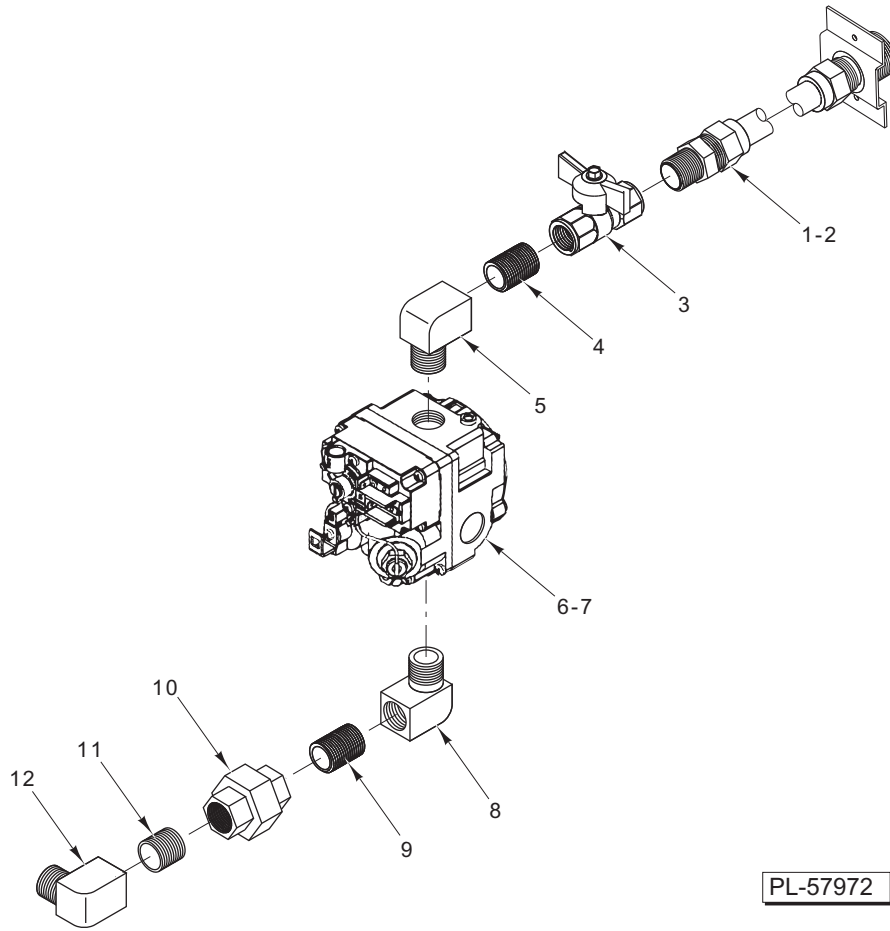

GAS VALVE (1GRC & 1GRD SERIES) (PREVIOUS CONSTRUCTION)

ILLUS. PL-57972	PART NO.	NAME OF PART	AMT.
1	00-427882-000G2	Gas Inlet (1GR45C & 1GR45D).....	1
2	00-427882-000G3	Gas Inlet (1GR65/85C & 1GR65/85D).....	1
3	00-428472-00001	Valve – Ball	1
4	FP-035-91	Pipe 1/2 x 1 1/8 TBE.....	1
5	FP-086-74	Elbow – Street 1/2 x 90 Deg. (Brass)	1
*6	00-410841-00028	Valve – Combination (NAT) (Electronic Ignition).....	1
*7	00-410841-00029	Valve – Combination (LP) (Electronic Ignition)	1
8	FP-086-74	Elbow – Street 1/2 x 90 Deg. (Brass)	1
9	FP-035-91	Pipe 1/2 x 1 1/8 TBE.....	1
10	FP-022-11	Union – Pipe	1
11	FP-035-94	Pipe 1/2 x 1 1/2 TBE.....	1
12	FP-086-74	Elbow – Street 1/2 x 90 Deg. (Brass)	1
	00-427751-000G1	Harness – Section	1

* Order harness 00-427751-000G1 when replacing valve.

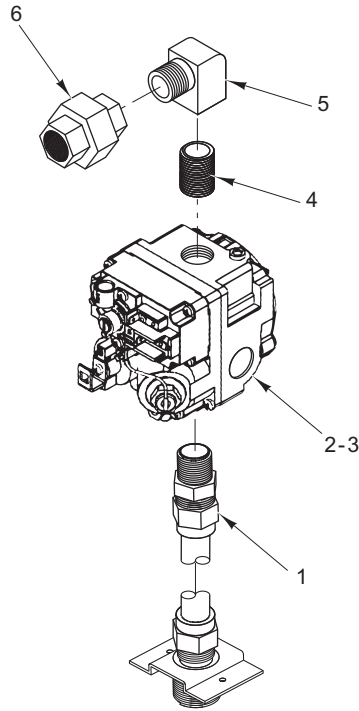

PL-59258

GAS VALVE (1GRC & 1GRD SERIES) (CURRENT CONSTRUCTION)

ILLUS.	PART NO.	NAME OF PART	AMT.
PL-59258			
1	00-427882-000G3	Gas Inlet	1
2	00-410841-00028	Valve – Combination (NAT) (Electronic Ignition).....	1
3	00-410841-00029	Valve – Combination (LP) (Electronic Ignition)	1
4	FP-013-17	Elbow – Pipe 1/2 x 90 Deg	1
5	FP-035-95	Pipe 1/2 x 2 TBE.....	1
6	FP-022-11	Union – Pipe	1

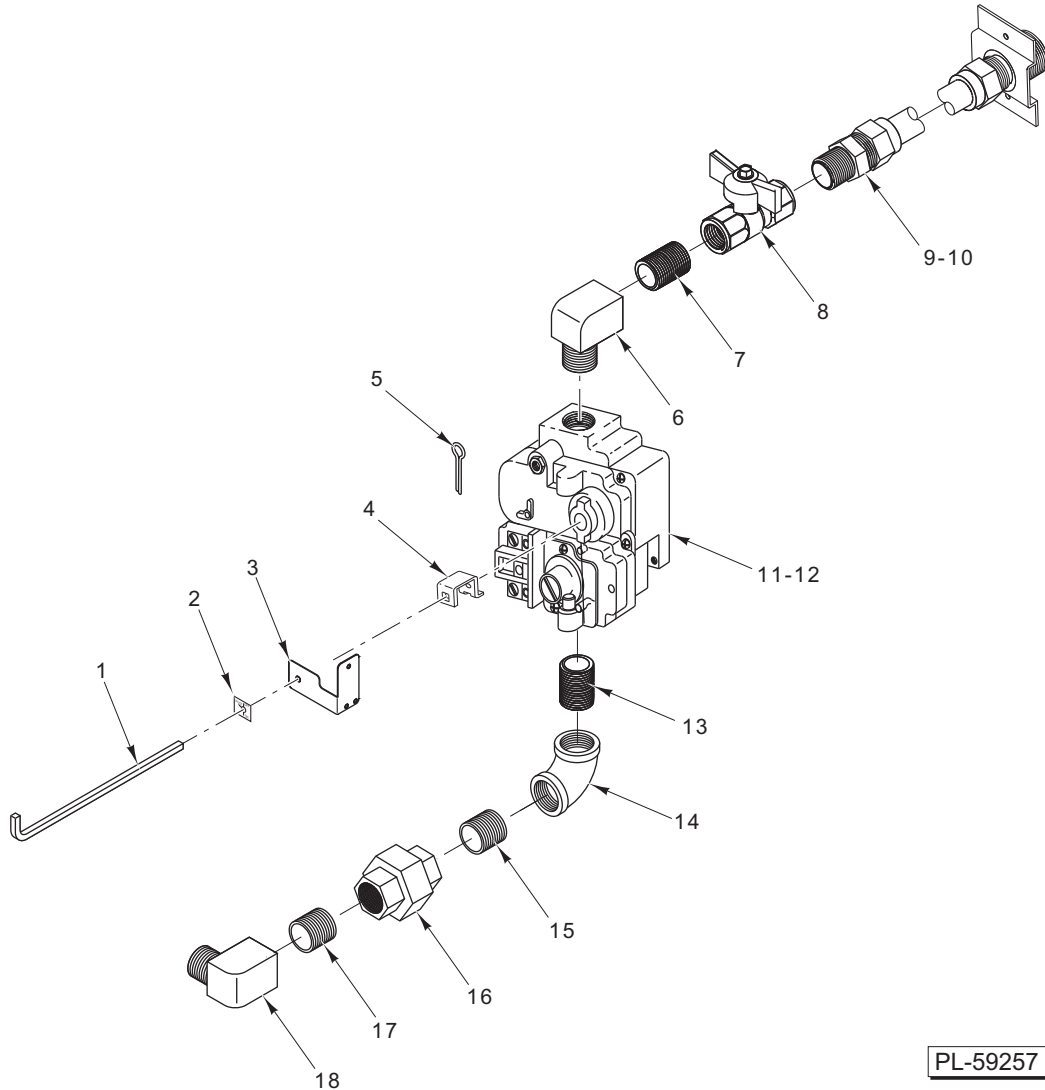

GAS VALVE (1GRM SERIES) (PREVIOUS CONSTRUCTION)

ILLUS.	PART NO.	NAME OF PART	AMT.
1	00-413433-00006	Lever – Valve	1
2	00-417896-00001	Plate – Control Valve	1
3	00-428755-00002	Bracket – Pilot Lever	1
4	00-412080-00001	Adapter – Knob (Use Existing Screw Provided With Knob)	1
5	PC-003-38	Pin – Cotter	1
6	FP-086-74	Elbow – Street 1/2 x 90 Deg. (Brass)	1
7	FP-035-91	Pipe 1/2 x 1 1/8 TBE	1
8	00-428472-00001	Valve – Ball	1
9	00-427882-000G1	Gas Inlet (1GR35M, 1GR45M, 1GR65M)	1
10	00-427882-000G2	Gas Inlet (1GR85M)	1
11	00-410841-00022	Valve – Combination (NAT) (Manual Ignition)	1
12	00-410841-00023	Valve – Combination (LP) (Manual Ignition)	1
13	FP-035-95	Pipe 1/2 x 2 TBE	1
14	FP-077-68	Elbow – Pipe 1/2 x 90 Deg.	1
15	FP-035-94	Pipe 1/2 x 1 TBE	1
16	FP-022-11	Union – Pipe	1
17	FP-035-91	Pipe 1/2 x 1 1/8 TBE	1
18	FP-086-74	Elbow – Street 1/2 x 90 Deg. (Brass)	1

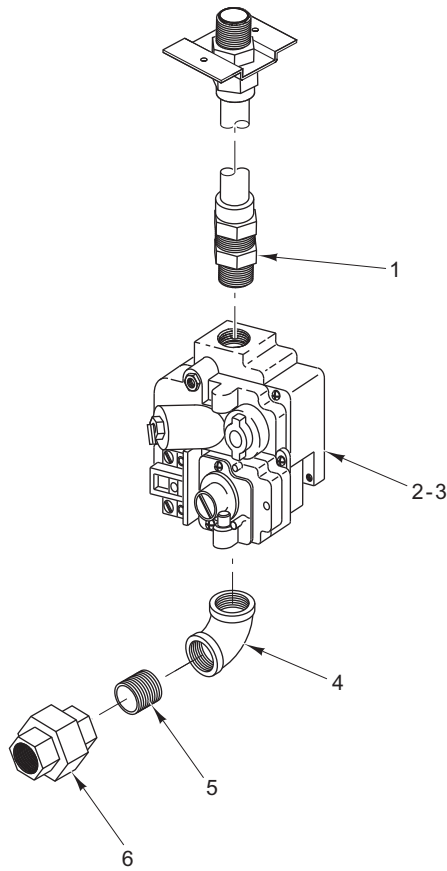

PL-59264

GAS VALVE (1GRM SERIES) (CURRENT CONSTRUCTION)

ILLUS.	PART NO.	NAME OF PART	AMT.
PL-59264			
1	00-427882-000G3	Gas Inlet	1
2	00-410841-00022	Valve – Combination (NAT) (Manual Ignition).....	1
3	00-410841-00023	Valve – Combination (LP) (Manual Ignition)	1
4	FP-013-17	Elbow – Pipe 1/2 x 90 Deg.	1
5	FP-035-95	Pipe 1/2 x 2 TBE.....	1
6	FP-022-11	Union – Pipe	1

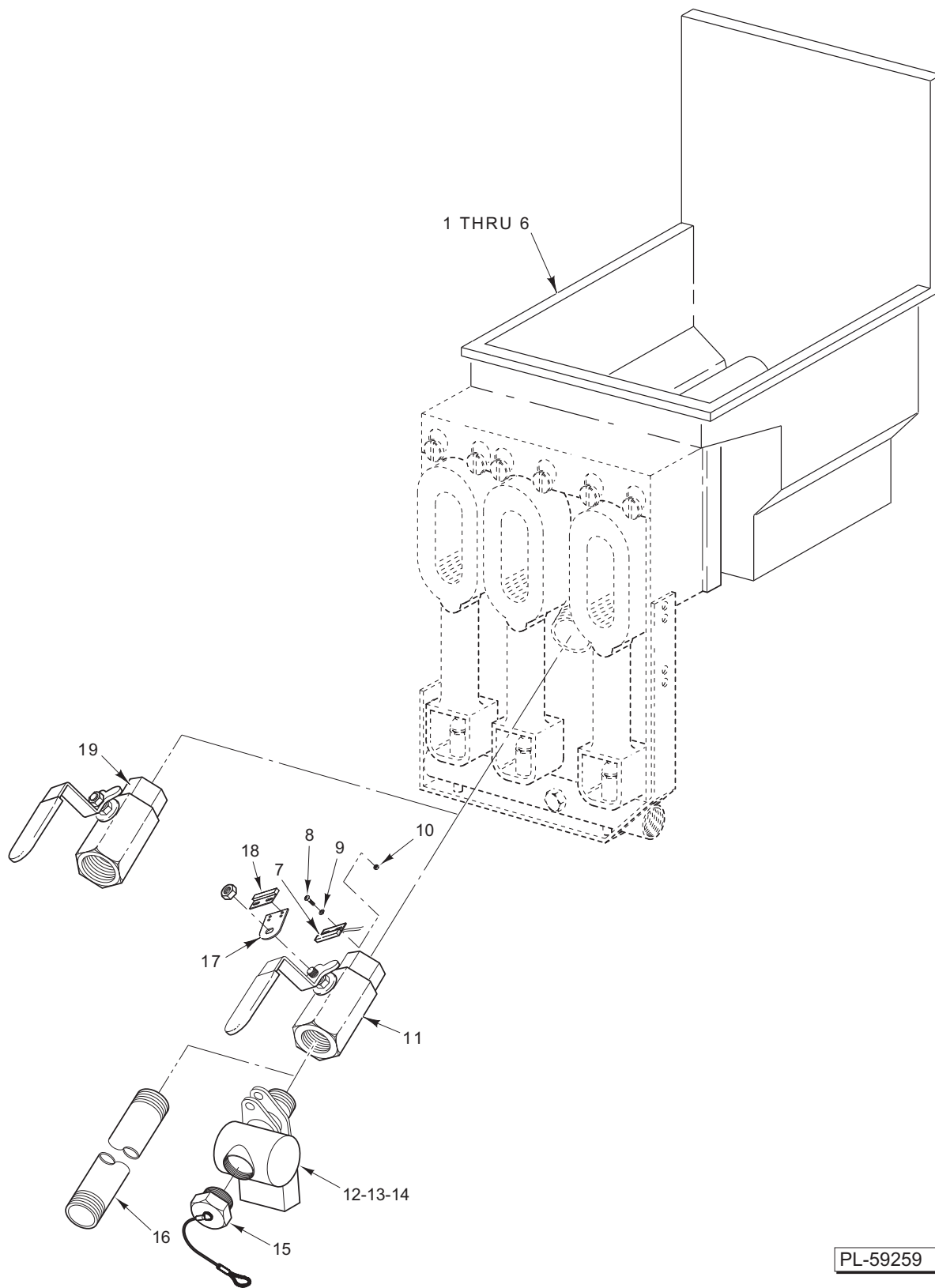

PL-59259

TANK AND DRAIN ASSEMBLY

TANK AND DRAIN ASSEMBLY

ILLUS.	PART NO.	NAME OF PART	AMT.
	PL-59259		
1	00-499700-000G2	Tank Assy. (1GR35M) (SST).....	1
2	00-499701-000G2	Tank Assy. (1GR45 Series) (SST).....	1
3	00-499702-000G2	Tank Assy. (1GR65 Series) (SST).....	1
4	00-499703-000G2	Tank Assy. (1GR85C/D & 1GR85CF/DF) (SST).....	1
5	00-956908-000G1	Tank Assy. (1GR45CF/DF).....	1
6	00-956908-000G2	Tank Assy. (1GR65CF/DF).....	1
7	00-426805-000G1	Switch Assy. (1GR45C/D & 1GR65C/D).....	1
8	SC-018-55	Mach. Screw 10-32 x 7 ³ / ₄ Rd. Slotted Hd.	4
9	WL-003-03	Lockwasher Helical 4.....	4
10	NS-044-01	Nut Assy. 4-40 KEPS.....	4
11	00-426803-000G9	Valve Assy. – Drain (With Magnet) (RH) (1 ¹ / ₄ In.) (1GR45C/D & 1GR85C/D).....	1
12	00-956829-000G1	Pipe – Drain (1GR45CF/DF & 1GR85CF/DF).....	1
13	00-420726-00002	Flange – Pipe (1 ¹ / ₄ In.) (1GR45CF/DF & 1GR85CF/DF).....	1
14	00-420553-00002	Gasket – Silicone (1GR45CF/DF & 1GR85CF/DF).....	1
15	00-497571-000G1	Plug – Drain (1GR45CF/DF & 1GR85CF/DF).....	1
16	FP-085-74	Pipe 1 ¹ / ₄ x 6 ³ / ₄ (1GR35, 1GR45C/D, 1GR65C/D, & 1GR85C/D).....	1
17	00-426798-00002	Plate – Switch (1GR45C/D & 1GR65C/D).....	1
18	00-426801-00002	Switch – Mounted (1GR45C/D & 1GR65C/D).....	1
19	00-958392-000G2	Valve Assy. – Drain (RH) (1 ¹ / ₄ In.) (1GR35/45/65/85M).....	1
	FP-028-14	Plug – Pipe 1 ¹ / ₂	1
	00-499486-00001	Clip – Drain Pipe.....	1
	00-497572-000G2	Pipe – Boil Out Bypass (With Hose Fitting).....	1

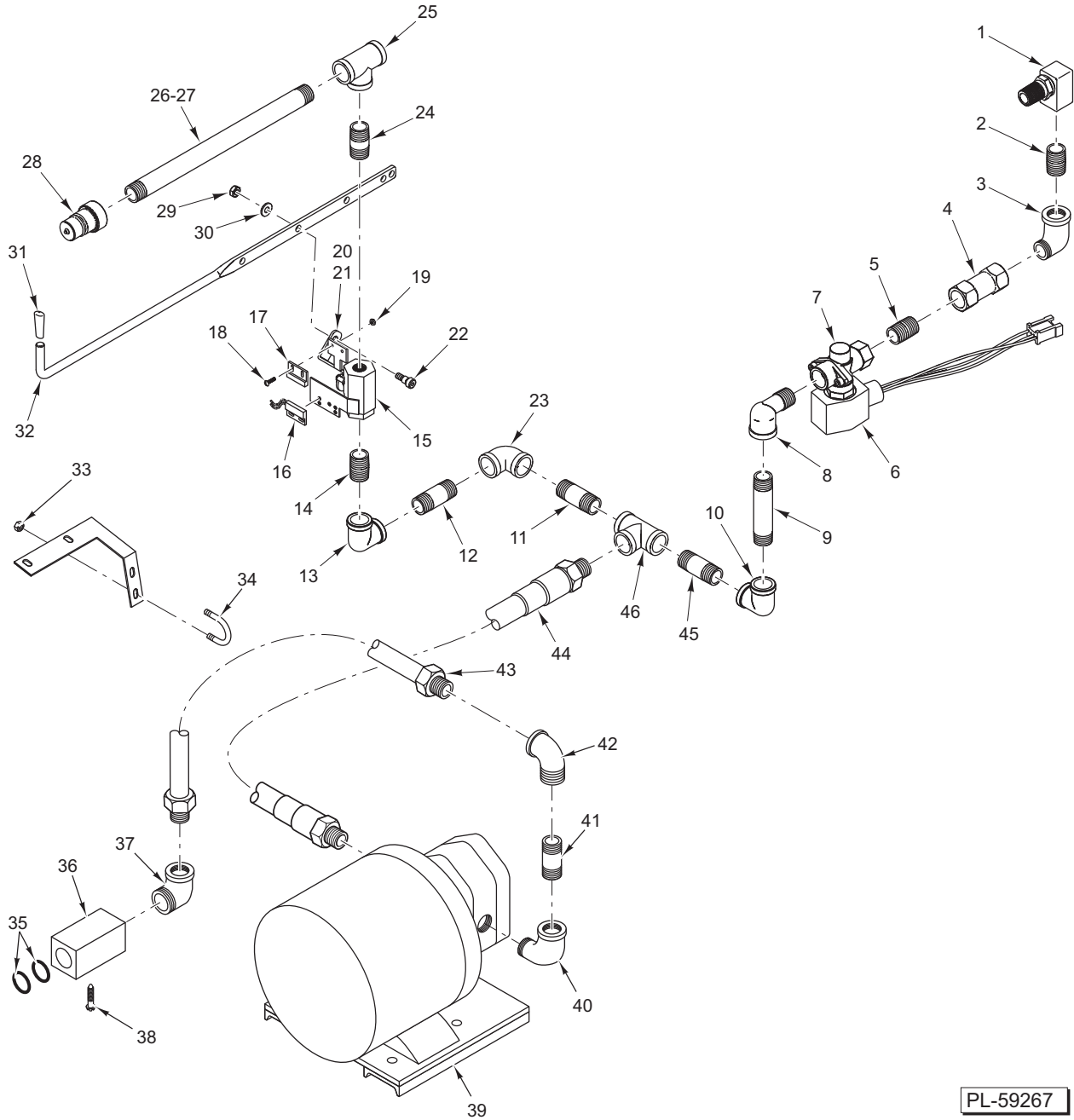

PL-59267

OIL RETURN (1GR45CF/DF & 1GR85CF/DF)

OIL RETURN (1GR45CF/DF & 1GR85CF/DF)

ILLUS. PL-59267	PART NO.	NAME OF PART	AMT.
1	00-419251-00001	Fitting – 90 Deg. Swivel	1
2	FP-035-91	Pipe 1/2 x 1 1/8 TBE.....	1
3	FP-013-17	Elbow – Street 1/2 x 90 Deg.....	1
4	00-418786-00001	Valve – Check.....	1
5	FP-035-91	Pipe 1/2 x 1 1/8 TBE.....	1
6	00-428691-00002	Valve Solenoid (120 V.).....	1
7	FP-035-91	Pipe 1/2 x 1 1/8 TBE.....	1
8	FP-013-17	Elbow – Pipe 1/2 x 90 Deg.....	1
9	FP-035-96	Pipe 1/2 x 2 1/2 TBE	1
10	FP-077-68	Elbow 1/2 x 90 Deg.....	1
11	FP-035-95	Pipe 1/2 x 2 TBE.....	1
12	FP-035-95	Pipe 1/2 x 2 TBE.....	1
13	FP-077-68	Elbow 1/2 x 90 Deg.....	1
14	FP-035-91	Pipe 1/2 x 1 1/8 TBE.....	1
15	00-428753-00001	Valve – Oil Discharge.....	1
16	00-426805-000G2	Switch Assy.....	1
17	00-426801-00002	Switch – Valve Mounted.....	1
18	SC-018-55	Mach. Screw 4-40 x 1/2 Phil. Pan Hd.....	4
19	NS-044-01	Nut Assy. 4-40 Hex KEPS.....	4
20	00-428697-00001	Actuator – Oil Discharge.....	1
21	00-428694-000G1	Valve – Discard (LH) (Incls. Items 15 thru 20).....	1
22	SC-116-19	Shoulder Screw 1/4-20 x 3/8 Hex. Socket Hd.....	1
23	FP-077-68	Elbow 1/2 x 90 Deg.....	1
24	FP-035-95	Pipe 1/2 x 2 TBE.....	1
25	FP-019-25	Tee 1/2 x 1/2 x 1/2	1
26	FP-036-91	Pipe 1/2 x 9 1/2 TBE (1GR45CF/DF).....	1
27	FP-090-81	Pipe 1/2 X 13 1/2 TBE (1GR65CF/DF & 1GR85CF/DF).....	1
28	00-418781-00001	Disconnect – Male	1
29	NS-046-52	Nut Assy. 1/4-20 Hex KEPS	1
30	WS-029-49	Washer.....	1
31	00-416435-00002	Grip (Yellow)	1
32	00-428693-00005	Rod – Pull Kleenscreen	1
33	NS-046-52	Nut Assy. 1/4-20 Hex.....	2
34	00-521820	U-Bolt.....	1
35	00-426567-00002	O-Ring (Viton).....	2
36	00-426567-00003	Receptacle – Oil Suction	1
37	FP-013-17	Elbow – Street 1/2 x 90 Deg.....	1
38	SC-114-01	Mach. Screw 10-32 x 3/8 Hex Washer Hd.....	1
39	00-417792-00005	Pump Motor Assy. (115 V., 60 HZ.) (8 G.P.M.).....	1
40	FP-077-68	Elbow 1/2 x 90 Deg.....	1
41	FP-035-95	Pipe 1/2 x 2 TBE.....	1
42	FP-077-68	Elbow 1/2 x 90 Deg.....	1
43	00-426602-00004	Tube – Suction Flex (19 In.).....	1
44	00-426602-00001	Tube – Flex (12 In.).....	1
45	FP-035-91	Pipe 1/2 x 1 1/8 TBE.....	1
46	FP-019-25	Tee 1/2 x 1/2 x 1/2	1
	00-422281-00008	Hose – Discard (4 Ft.).....	1
	00-956900-00001	Bracket – Suction Block.....	1

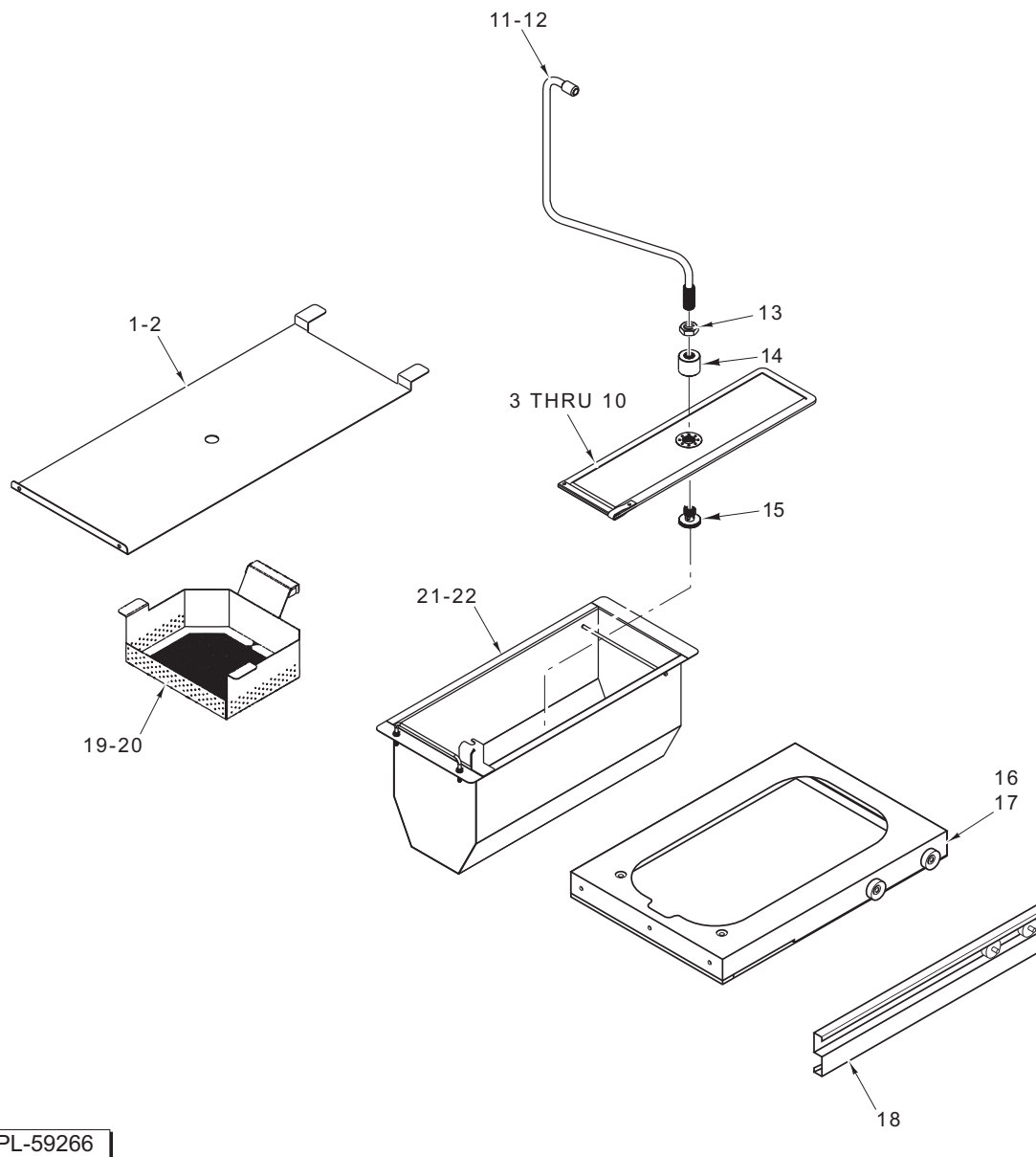

PL-59266

FILTER ASSEMBLY

FILTER ASSEMBLY

ILLUS. PL-59266	PART NO.	NAME OF PART	AMT.
1	00-956904-00001	Splash Guard (1GR45CF/DF)	1
2	00-956904-00002	Splash Guard (1GR65CF/DF & 1GR85CF/DF)	1
3	00-499087-00002	Screen – Fine Mesh Filter (1GR45CF/DF)	1
4	00-499087-00004	Screen – Fine Mesh Filter (1GR65CF/DF & 1GR85CF/DF)	1
5	00-499085-00003	Insert – Filter Screen (1GR45CF/DF)	1
6	00-499085-00006	Insert – Filter Screen (1GR65CF/DF & 1GR85CF/DF)	1
7	00-499086-00002	Filter – Envelope (1GR45CF/DF)	1
8	00-499086-00003	Filter – Envelope (1GR65CF/DF & 1GR85CF/DF)	1
9	00-499089-00002	Clip – Filter (1GR45CF/DF)	1
10	00-499089-00003	Clip – Filter (1GR65CF/DF & 1GR85CF/DF)	1
11	00-499081-000G5	Tube – Suction (1GR45CF/DF)	1
12	00-499081-000G7	Tube – Suction (1GR65CF/DF & 1GR85CF/DF)	1
13	NS-017-49	Jam Nut	1
14	00-499083-00002	Coupling	1
15	00-499084-00002	Knob	1
16	00-428180-000G6	Drawer Assy. (1GR45CF/DF)	1
17	00-428180-000G7	Drawer Assy. (1GR65CF/DF & 1GR85CF/DF)	1
18	00-958026-000G2	Guide – Roller	1
19	00-426606-000G5	Basket – Scrap (1GR45CF/DF)	1
20	00-426606-000G7	Basket – Scrap (1GR65CF/DF & 1GR85CF/DF)	1
21	00-958000-000G1	Pan Assy. – Filter (1GR45CF/DF)	1
22	00-958000-000G2	Pan Assy. – Filter (1GR65CF/DF & 1GR85CF/DF)	1
	00-499486-00001	Clip – Drain Pipe	1
	00-413927-00001	Grommet – Rubber	1
	00-499085-00005	Insert – Envelope (1GR45CF/DF)	1
	00-499085-00006	Insert – Envelope (1GR65CF/DF & 1GR85CF/DF)	1

