

PROCESSING

Berkel**M3000**
CONTINUOUS FEED FOOD PROCESSOR

Model M3000

**FEATURES**

Berkel Model M3000 continuous feed food processor is a high-performance machine that quickly and conveniently, slices, dices, shreds, grates, and juliennes vegetables, fruits and cheese. The M3000 should not be used to dice or cube cheese or meat. Constructed of heavy-duty stainless steel and aluminum, the compact M3000 is easy to move from one location to another. The continuous feed attachment includes an automatic start/stop function, feed tube and design that allows the operator to load product with both hands for the fastest possible processing. The dual interlock boosts operator protection. The M3000 has a variety of cutting plates to optimize the versatility and productivity of this superior machine.

Designed and Assembled in U.S.A.

- M3000** Continuous Feed Food Processor

STANDARD FEATURES

- Slices, dices, shreds, grates and juliennes fruit, vegetables, dry bread, cheese, nuts, etc.
- The M3000 should not be used to dice or cube cheese or meat.
- Prepares 800-950 lbs. per hour.
- 1-speed, ¾ HP, thermal motor protection.
- Furnished in 115/60/1, UL listed.
- Optimal speed setting and perfect cutting results for the required applications.
- Includes feed head and either ejector plate or wiper blade depending on model.
- Model M3000 is furnished with a 1/8" (3 mm) shredder plate and 1/8" (3 mm) slicing plate.
- Stainless steel machine base and aluminum feed assembly for increased durability.

OPTIONS

- The M3000-7 is furnished with an aluminum ejector plate system in 115/60/1
- The M3000-8 is furnished with a wiper blade ejection system in 115/60/1
- The M3000-10 is furnished with a wiper blade ejection system in 230/60/1
- The M3000-12 is furnished with a wiper blade ejection system in 220/50/1 (not UL Listed)

ACCESSORIES (Packaged & Sold Separately)

- Slicing Plates – 1/32" (1 mm), 1/16" (2 mm), 1/8" (3 mm), 3/16" (5 mm), 5/16" (8 mm), 3/8" (11 mm), 1/2" (14 mm)
- Crimping Plate – 3/16" (5 mm)
- Shredder Plates – 1/16" (2 mm), 1/8" (3 mm), 3/16" (5 mm), 7/16" (7 mm) and Fine Shredder
- Julienne Plate – 1/32" x 1/32" (1 x 1 mm), 3/32" x 3/32" (2.5 x 2.5 mm), 3/16" x 3/16" (5 x 5 mm), 1/4" x 1/4" (8 x 8 mm)
- Dicing Grid – 3/8" (11 mm), 1/2" (14 mm), 7/8" (22 mm), 1/4" (8 mm)
- Special 6-pack of Accessories (see AQ or Price Book)
- Special 8-pack of Accessories (see AQ or Price Book)
- Storage Rack – 3 Plates
- Storage Rack – 6 Plates

Berkel

a division of ITW Food Equipment Group LLC

www.berkequipment.com

P.O. Box 696 ■ Louisville, KY 40201 ■ Toll-free: 1-800-814-2028 ■ Local: 502-778-2791 ■ Quote & Order Fax: 1-800-444-0602



M3000

CONTINUOUS FEED FOOD PROCESSOR

SPECIFICATIONS

Motor: ¾ hp, 1-speed, thermal motor protection with automatic reset.

Electrical: Furnished in 115/60/1, 12.5 amps, UL Listed; 230/60/1, 6.3 amps, UL Listed; 220/50/1, 5.8 amps, not UL Listed. All models are furnished with a 3-wire electrical cord and plug. Cord is 6' in length.

Finish/Construction: Machine base of stainless steel. Polished aluminum continuous feed attachment and either wiper blade or ejector plate depending on model. Cutting plates of stainless steel or aluminum. All blades of stainless steel.

Controls: Rear mounted and shielded on/off switch.

Speeds: 1 speed (350 rpm) for slicing, dicing, shredding, crimping and grating.

Operator Protection: Feed hopper and "C" hopper interlocks keep machine from operating unless in the proper position.

Capacity: 800-950 lbs. per hour.

Warranty: Parts, labor and travel coverage for one year, exclusive of wear items, cutting edges and dicing grids.

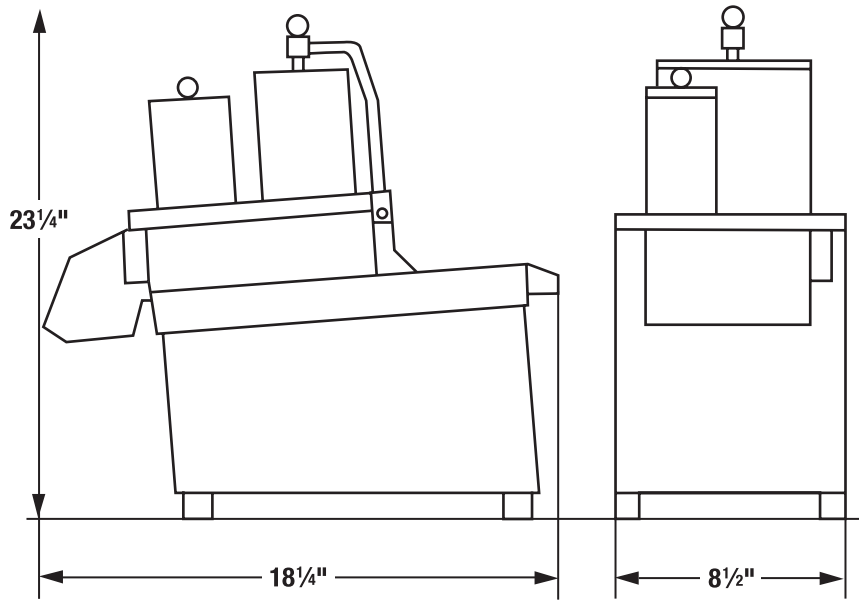

Continuous Feed

MODEL NO.	CAPACITY	PRODUCT DIMENSIONS			WEIGHT
		WIDTH	DEPTH	HEIGHT	
M3000	800-950 lbs. per hour	8½" (216 mm)	18¼" (465 mm)	23¼" (590 mm)	Net 56 lbs. (25.5 kg) Ship 63 lbs. (29 kg)

MOTOR	ELECTRICAL	CUTTING SPEED	BOX DIMENSIONS		
			WIDTH A	DEPTH B	HEIGHT C
1 Speed ¾ HP	115/60/1	350 rpm	12½" (318 mm)	22" (559 mm)	25" (635 mm)



www.berkelequipment.com

P.O. Box 696 ■ Louisville, KY 40201 ■ Toll-free: 1-800-814-2028 ■ Local: 502-778-2791 ■ Quote & Order Fax: 1-800-444-0602

NOTE: As we continually strive to improve our products, specifications are necessarily subject to change without notice.