



Profit from the Eagle Advantage®

Specification Sheet

Short Form Specifications

Eagle Hot Food Tables, open base design, model _____ . Top and body to be heavy gauge type 430 stainless steel. Beaded top openings to be 12 $\frac{3}{32}$ " x 20 $\frac{3}{32}$ ". Heating compartments to be 8"-deep, galvanized, and insulated on all four sides and bottom with 1" fiberglass or equal. Recessed control panel, with individual infinite controls, offer high and low settings. Each compartment fitted with 500-watt heating element for 120-volt units, and 750-watt heating element for 240-volt units. 6' cord and plug extends from the bottom right hand side of the unit. Furnish with polycarbonate cutting board. Legs to be 1 $\frac{1}{2}$ " O.D. tubing, with adjustable undershelf and adjustable bullet feet.



#DHT3-120 hot food table

Options / Accessories

- Spillage pans
- Bolted-in undershelf
- Overshelves
- Tray slides
- Tray shelf
- Dish shelf
- Rolltop cover
- Hardwood cutting board

* See Catalog Sheet #EG30.18 for more information on Flex-Master® overshelves

EAGLE GROUP
100 Industrial Boulevard, Clayton, DE 19938-8903 USA
Phone: 302-653-3000 • Fax: 302-653-2065
www.eaglegrp.com

Foodservice Division: Phone 800-441-8440
MHC/Retail Display Divisions: Phone 800-637-5100

For custom configuration or fabrication needs, contact our **SpecFAB® Division**.
Phone: 302-653-3000 • Fax: 302-653-3091 • e-mail: specfab@eaglegrp.com

Spec sheets available for viewing, printing or downloading from our online literature library at www.eaglegrp.com

Eagle Foodservice Equipment, Eagle MHC, SpecFAB®, and Retail Display are divisions of Eagle Group. ©2012 by the Eagle Group

Central Restaurant Products

Item No.: _____
Project No.: _____
S.I.S. No.: _____

Electric Hot Food Tables— Open Base, Stationary

MODELS:

- DHT2-120
- DHT4-120
- SDHT2-120
- SDHT4-120
- DHT2-240*
- DHT4-240*
- SDHT2-240*
- SDHT4-240*
- DHT3-120
- DHT5-240*
- SDHT3-120
- SDHT5-240*
- DHT3-240*
- SDHT3-240*

* These units are available in three-phase. To order, add suffix "-3". Ex: DHT2-240-3

Construction

- Table body and top are constructed of highly polished 22 gauge 430 series stainless steel.
- Top features die stamped beaded openings measuring 12 $\frac{3}{32}$ " x 20 $\frac{3}{32}$ " (307 x 510mm).
- A poly cutting board, 8" (203mm) wide and $\frac{1}{2}$ " (13mm) thick, is mounted on stainless steel brackets located on control side of unit.
- Legs offered in galvanized or stainless steel.
- All models are 30 $\frac{1}{2}$ " (774mm) wide and 34" (863mm) high.

Controls

- Individual infinite controls offer high and low selections along with eight other temperature settings.
- Indicator light remains on continuously while control is in "ON" position.

Heat compartments

- Each heat compartment is 8" (203mm) deep and lined with 22 gauge galvanized steel.
- Each compartment is insulated on all four sides and bottom with 1" (25mm) thick fiberglass or equal.

Electrical

- Each compartment is fitted with a 500-watt or 750-watt tubular element above the insulated bottom. 500-watt element is standard on units wired for 110-120 volts; 750-watt element is standard for units wired for 220-240 volts.
- 6' (1829mm) cord with plug extends from the bottom of the right hand control side as standard equipment.
- 120-volt models are single phase. 240-volt models available in single- or three-phase.

Certifications / Approvals



AUTOQUOTES



EG30.00 Rev. 01/12



Profit from the Eagle Advantage®

Item No.: _____
 Project No.: _____
 S.I.S. No.: _____

Electric Hot Food Tables—Open Base, Stationary Ê

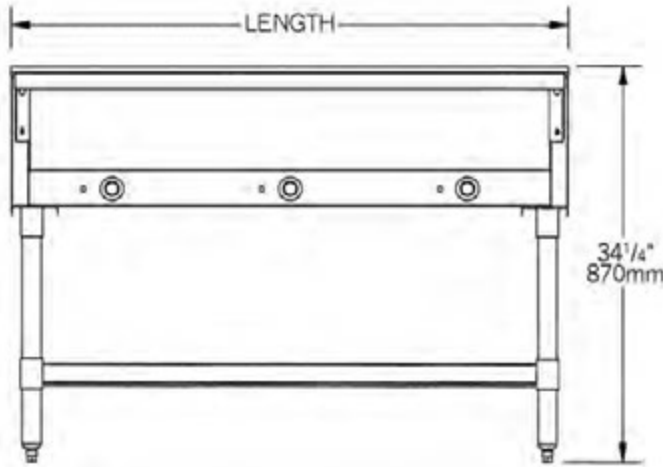

FRONT VIEW

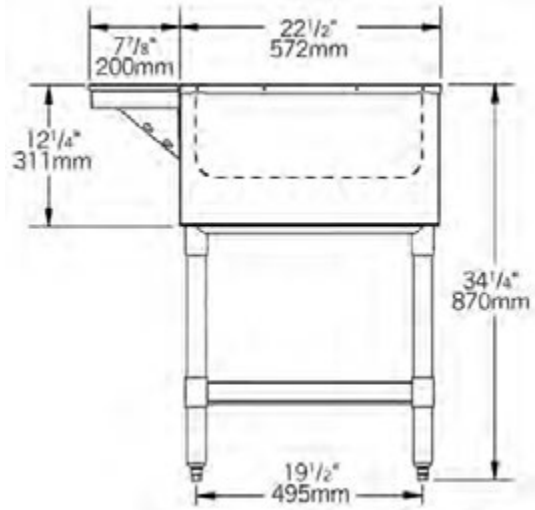

SIDE VIEW

SINGLE-PHASE		THREE-PHASE		# of openings	electrical data	length		weight	
WITH GALVANIZED LEGS & UNDERSHELF model #	WITH STAINLESS STEEL LEGS & UNDERSHELF model #	WITH GALVANIZED LEGS & UNDERSHELF model #	WITH STAINLESS STEEL LEGS & UNDERSHELF model #			in.	mm	lbs.	kg
DHT2-120	SDHT2-120	n/a	n/a	2	1000W, 120V	33"	838	91	41.3
DHT2-240	SDHT2-240	DHT2-240-3	SDHT2-240-3	2	1500W, 240V	33"	838	91	41.3
DHT3-120	SDHT3-120	n/a	n/a	3	1500W, 120V	48"	1219	128	58.1
DHT3-240	SDHT3-240	DHT3-240-3	SDHT3-240-3	3	2250W, 240V	48"	1219	128	58.1
DHT4-120	SDHT4-120	n/a	n/a	4	2000W, 120V	63 3/4"	1613	191	86.6
DHT4-240	SDHT4-240	DHT4-240-3	SDHT4-240-3	4	3000W, 240V	63 3/4"	1613	191	86.6
DHT5-240	SDHT5-240	DHT5-240-3	SDHT5-240-3	5	3750W, 240V	79"	2007	241	109.3

Note: 240-volt units also available in 208 volt. To order, replace suffix "-240" with suffix "-208". Example: DHT3-208

RECEPTACLE CONFIGURATIONS REQUIRED

15A 125V model #	15A 250V model #	20A 250V model #	30A 250V model #	30A 125V model #	20A 3Ø 250V all three-phase models
(S)DHT2-120 (S)DHT3-120	(S)DHT2-240 (S)DHT3-240	(S)DHT4-240	(S)DHT5-240	(S)DHT4-120	
furnished with NEMA 5-15 plug	furnished with NEMA 6-15 plug	furnished with NEMA 6-20 plug	furnished with NEMA 6-30 plug	furnished with NEMA 5-30 plug	furnished with NEMA 15-20 plug

FLEX-MASTER® Overshelf Kits

Both kits include two 16/304 overshelves and four 30" (762mm) posts. Add suffix specified to order kit (example: DHT2-120-FMU), or design your own using standard components from EG30.18.

description	add suffix
10" (254mm) overshelves	-FM
15" (381mm) overshelves, plus one ladle rack	-FMU

EAGLE GROUP
 100 Industrial Boulevard, Clayton, DE 19938-8903 USA
 Phone: 302-653-3000 • Fax: 302-653-2065
 www.eaglegrp.com

Foodservice Division: Phone 800-441-8440
 MHC/Retail Display Divisions: Phone 800-637-5100

Printed in U.S.A.
 ©2012 by Eagle Group

Rev. 01/12

Spec sheets available for viewing, printing or downloading from our online literature library at www.eaglegrp.com

Although every attempt has been made to ensure the accuracy of the information provided, we cannot be held responsible for typographical or printing errors. Information and specifications are subject to change without notice. Please confirm at time of order.