

Modular Add-On Units

ASSEMBLY INSTRUCTIONS

CAUTION

INSPECT CONTENTS IMMEDIATELY AND FILE CLAIM WITH DELIVERING CARRIER FOR ANY DAMAGE.

SAVE YOUR BOX AND ALL PACKING MATERIALS.

YOU ARE RESPONSIBLE FOR DAMAGE TO YOUR UNIT IF RETURNED IMPROPERLY PACKED.

Assembly for Models #MA1 through #MA6

(Refer to *figure 1* at right.)

Note: In order to attach the leg channel to the MA body, holes must be punched into the MA body.

- 1) Place leg channel flush to outside edge of flange at desired side (left or right), opposite the side that will be joined to the underbar unit. Mark for holes.
- 2) Set leg channel aside and drill 7/64" diameter holes in bottom of the MA unit.
- 3) Attach leg channel to the MA body with self-tapping screws. Screw until tight.
- 4) Insert crossbraced leg assembly into both gussets of the leg channel. Secure with set screws.

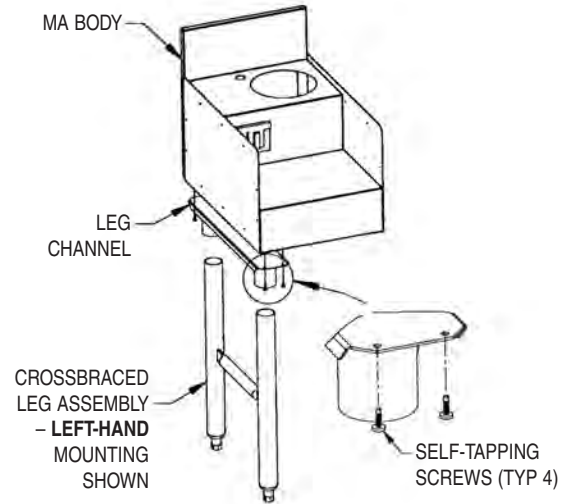

figure 1

(See back page for #MA7 assembly.)

INSTALLATION INSTRUCTIONS

Parts List

qty	part #	description
10 . . .	300794	#8 x 1/2 drive screws
1 *	modular add-on unit

* Part number varies upon order.

Step 1 - Align units to be joined.

Line up the modular add-on unit so that the backsplashes and fronts are flush with each other. If available, use a "C"-clamp to hold the units together temporarily.

Step 2 - Attach the MA unit to the underbar unit.

Using the side panel of the MA unit as a hole template, drive the screws (using a drill) through the predrilled holes of the MA unit and into the side panel of the underbar unit. Remove the "C"-clamp if one has been applied.

Please note:

There are 10 holes in each of the MA unit's side panels. Be sure to use all of the holes on the side or sides that need to be attached to an adjacent unit.

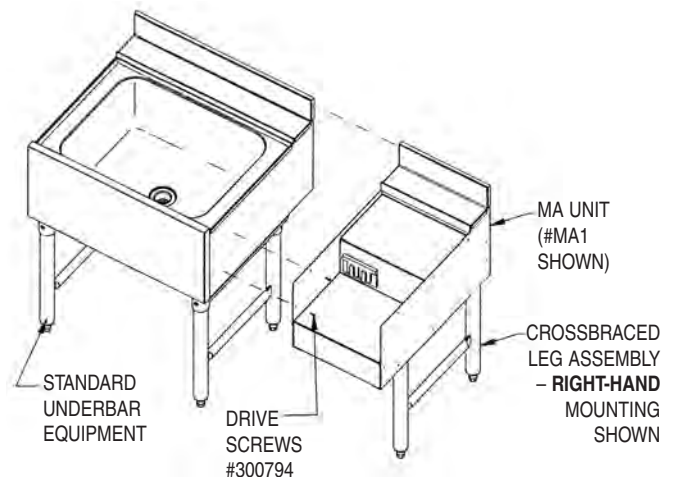

Modular Add-On Units

ASSEMBLY INSTRUCTIONS

Assembly for Models #MA7

(Refer to figure 2 at right.)

Note: In order to attach the leg channel to the MA7 body, holes must be punched into the MA7 body.

- 1) Place leg channel flush to outside edge of flange at front edge of MA7 unit. Mark for holes.
- 2) Set leg channel aside and drill 7/64" diameter holes in the bottom of the MA7 unit.
- 3) Attach leg channel to the MA7 body with self-tapping screws. Screw until tight.
- 4) Insert crossbraced leg assembly into both gussets of the leg channel. Secure with set screws.

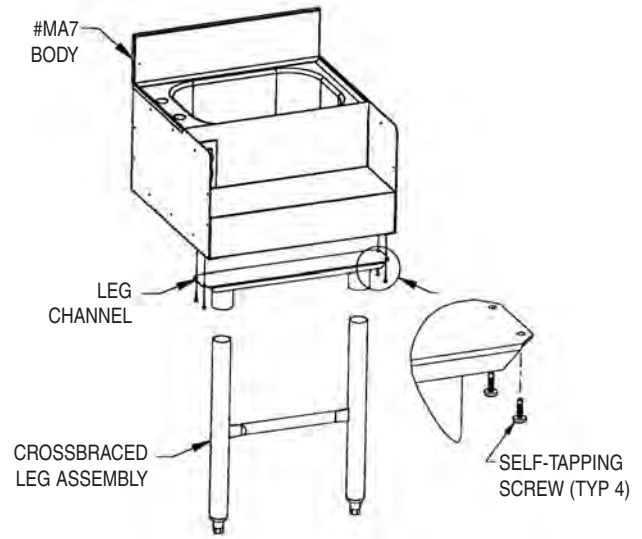

figure 2

INSTALLATION INSTRUCTIONS

Parts List

qty	part #	description
10 . . .	300794	#8 x 1/2 drive screws
1 *	modular add-on unit

* Part number varies upon order.

Step 1 - Align units to be joined.

Line up the modular add-on unit so that the backsplashes and fronts are flush with each other. If available, use a "C"-clamp to hold the units together temporarily.

Step 2 - Attach the MA7 unit to the underbar unit.

Using the side panel of the MA7 unit as a hole template, drive the screws (using a drill) through the predrilled holes of the MA unit and into the side panel of the underbar unit. Remove the "C"-clamp if one has been applied.

Please note:

There are 10 holes in each of the MA7 unit's side panels. Be sure to use all of the holes on the side or sides that need to be attached to an adjacent unit.

