



4427N Salad Top

Front-Breathing Self-Contained Salad Top Refrigerated Bases

Project _____
 Item _____
 Quantity _____
 CSI Section 11400
 Approved _____
 Date _____

4427N Salad Top: Front-Breathing Self-Contained Salad Top Refrigerated Bases

Models

- 4427N-6 Single section with doors, six pan capacity
- D4427N-6 Single section with drawers, six pan capacity



4427N-6

Standard Features

- Patented air screen ensures product stays cold without drying it out
- All 4400 Series units are 100% front breathing, which allows the unit to be pushed against a wall or built into a cabinet or an existing line up
- Durable, rugged stainless steel sides, top and front
- Features Delfield's exclusive ABS interior (on sides). ABS is extremely durable - it won't dent, chip or corrode and is backed by a limited lifetime warranty
- Delfield supplies 1/6 size pans and positive placement adapter bars for top opening
- Dual level pan brackets allow the pans to be lowered an additional inch in the unit without tools to provide additional pan temperature holding performance
- Salad top refrigerators are standard with 10" wide, dishwasher safe polyethylene cutting board treated with antimicrobial agent
- "D" prefix models feature Delfield's new drawer system. Drawers are backed by a 10-year warranty on the track assembly
- Environmentally friendly R404A refrigerant
- High density foamed in place environmentally friendly, Kyoto Protocol Compliant, Non ODP (Ozone Depletion Potential), Non GWP (Global

Warming Potential) polyurethane keeps energy costs low

- Black recessed quick grip handle
- Standard on 5" casters for easy cleaning and installation
- 6' cord and plug supplied
- One epoxy coated wire shelf standard, installed per door section
- ACT solid state electronic control
- One year parts and 90 day labor standard warranty

Options & Accessories

- Flat lift off cover
 - 18" wide single tier overshelf
 - Stainless steel finish on back
 - Plastic laminate on front
 - Additional wire shelves
 - 3" casters, 3.75" ride height
 - Door lock (solid door models only)
 - Exterior thermometer (solid door models only)
 - Glass door(s)
 - 220V/50 Hertz electrical system*
- * Inclusion of this option will alter electrical specifications of the unit

Specifications

Exterior top is one-piece, 22-gauge stainless steel with integral 2.12" (5.4cm) square nosing on the front. Top of drawer unit has one opening to accept six 1/6-size 4" (10cm) deep pans. Top of door unit has one opening to accept six 1/6-size 4" or 6" (10cm or 15cm) deep pans. Adapter bars and 1/6 size pans are supplied by Delfield. Lid is constructed of 20-gauge stainless steel. Temperature in top opening to maintain 33°F (1°C) to 41°F (5°C), with pans recessed 2.5" (6.4cm) at 86°F ambient room temperature, meeting NSF 7 requirements. One 27" x 10" x .5" (68.6cm x 25.4cm x 1.3cm) polyethylene cutting board treated with antimicrobial agent is mounted on the top at the front edge.

Dual level pan brackets allow the pans to be lowered an additional inch in the unit without tools to provide additional pan temperature holding performance.

Exterior back and bottom are two-piece 24-gauge galvanized steel. Exterior ends are stainless steel.

Interior sides are thermoformed ABS plastic with integral shelf supports. Base is fully insulated with high-density foamed in place environmentally friendly, Kyoto Protocol Compliant, Non ODP (Ozone Depletion Potential), Non GWP (Global Warming Potential) polyurethane.

Refrigeration system uses HFC-404A refrigerant. Compressor is 1/5 H.P., with condenser coil and hot gas condensate

evaporator mounted on rear of the cabinet. Evaporator coil is located on the interior rear wall of the cabinet. Refrigerant flow is controlled by a capillary tube. Cabinet maintains an interior cabinet temperature of 36°F to 40°F (2°C to 4°C).

ACT control: ACT electronic, solid state control, mounted on the exterior rear of the cabinet, allows unit to maintain precise temperatures in heavy duty conditions.

Electrical connection is 115 volt, 60 Hertz, single phase. Unit has a 6' (1.8m) long electrical cord and NEMA 5-15P plug.

Casters: Equipment is mounted on 5" (13cm) diameter plate casters with front two locking. Equipment clearance above the floor is 2.5" (6cm).

Doors have a 24-gauge stainless steel exterior, with thermoformed ABS plastic interior liner. Cabinet has one adjustable epoxy-coated wire shelf.

Drawers have 24-gauge stainless steel exterior with thermoformed ABS plastic interior liner. Drawer frames are 12-gauge stainless steel. Drawer slides are 11-gauge stainless steel with Delrin bearings. Top drawer holds one full size 12" x 20", 4"-6" (30.5cm x 50.8cm x 10.2cm) deep pan, and three 1/6 size pans. Bottom drawer holds one full size 12 x 20" and three 1/6 size 4" deep pans. Pans are supplied by others.



980 S. Isabella Rd.
 Mt. Pleasant, Michigan 48858

Phone: 800-733-8948 or 989-773-7981
 Fax: 800-669-0619

www.delfield.com





4427N Salad Top

Front-Breathing Self-Contained Salad Top Refrigerated Bases

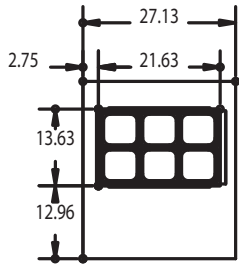

Pan Cutout Configuration

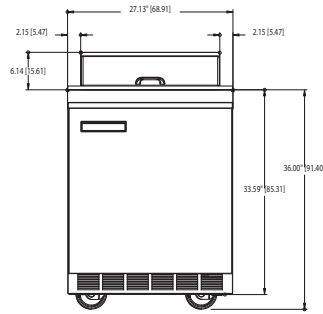

4427N-6 Elevation View

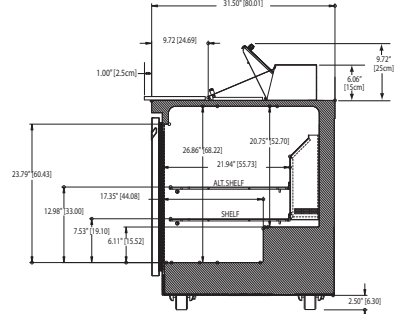

4427N-6 Right Side View

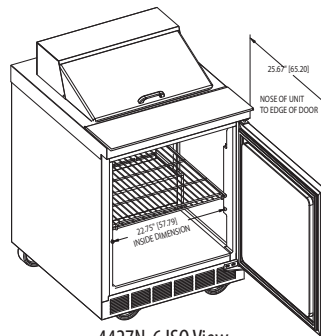

4427N-6 ISO View

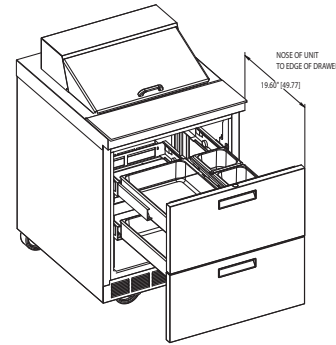

D4427N-6 ISO View

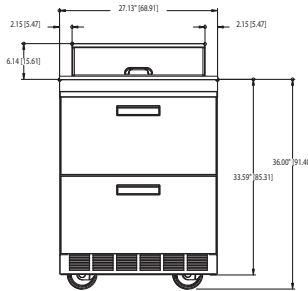

D4427N-6 Elevation View

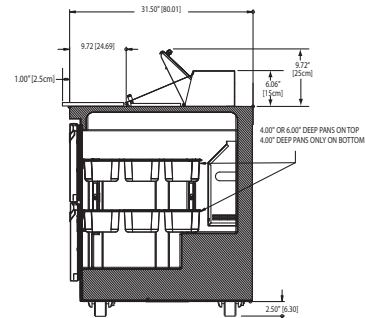

D4427N-6 Right Side View

INSTALLATION NOTE:

Refrigeration system is designed so that air will flow under the unit, through the compressor area and out the front of the unit. Any restriction to this air flow path will void the warranties.

PLEASE NOTE:

Air flow through the louver on the back of the unit is not necessary for operation, however, any air which passes through the louver is beneficial.

Specifications

Model	1/6 Size Pan Capacity	# Of Shelves	Shelf Area sq.ft.	Volume cu.ft	H.P.	V/Hz/Ph	Amps	Nema Plug	Ship Weight
4427N-6	6	1	3.17	8.20	1/5	115/60/1	7.2	5-15P	223lbs/101kg
D4427N-6	6	NA	NA	8.20	1/5	115/60/1	7.2	5-15P	245lbs/111kg

Delfield reserves the right to make changes to the design or specifications without prior notice.

980 S. Isabella Rd.
Mt. Pleasant, Michigan 48858

Phone: 800-733-8948 or 989-773-7981
Fax: 800-669-0619
www.delfield.com

Printed in the U.S.A.
DS4427N-5
04/11

