

TABLE TYPE, ELECTRIC KETTLES

*TILTING, "SPASH PROOF SERIES"
 SELF-CONTAINED, 2/3 STEAM JACKETED,
 3, 6 or 12 GALLONS (11, 23 or 45 LITERS)*

MODELS: KET-3-T KET-12-T
 KET-6-T

Cleveland Standard Features

- Manual tilting, balanced design
- Self-contained, easily installed - needs only an electrical hook-up
- Steam jacket filled with treated water, venting and/or refilling is not required
- Accurate, consistent solid state temperature controls (mechanical thermostate not as accurate) - less than ±1°C variance (ideal for simmering). Operating temperature range from 145° - 260°F (63°C - 127°C)
 Control panel includes:
 - LED indicator for heat cycle • LED indicator for low water
 - Power ON/OFF switch • Adjustable temperature control dial
- Water resistant controls, splash-proof construction
- Large pouring lip for high capacity and chunky products.
- Re-inforced rolled rim design prevents damage to kettle rim, eliminates "bar rim designs"
- Welded-in heating elements, (holds vacuum better, won't leak or loose water)
- Easily cleaned: kettle and all exterior surfaces are of type 304 stainless steel with an #4 finish
- Rear mounted easy access pressure gauge and pressure relief valve to prevent tampering. Color coded easy to read pressure gauge with "green" and "vent air zone"
- 50 psi steam jacket rating for higher cooking temperatures
- 50 psi safety valve
- Solid state water level control (no sight glass gauge to break or leak)
- Splash proof element cover with a double gasket seal
- **Self locking marine type tilting mechanism** prevents accidental spills. Balanced design makes it easy to tilt
- Standard voltage is 208-240 volts, 60 Hz, 3 phase, 3 wire. Model KET-6 and KET-12 are field rewirable to single phase
- Typical approvals include UL., CSA, CE, NSF and ASME

Options & Accessories

- Stainless Steel equipment stand with drain drawer and splash shield (ST-28)
- Hot and cold (DPK) or cold only (SPK) water faucet with swing spout. Requires mounting bracket (FBKT)
- 316 Stainless Steel kettle liner for high acid food products (316-G)
- High wattages (HW) and special voltages (see back page)
- Cooking Baskets (BS)
- Food Strainers (FS)
- Measuring Strips (MS)
- Spray Hose (PRS-K)
- Lift Off Cover (CL)
- Kettle Markings (KM)
- Protective Control Panel (PCE)



Short Form Specifications

Shall be CLEVELAND, electric kettle, Table Type, self-contained, tilting, Model KET - ____ - T; ____ gallons, ____ KW, ____ volt, ____ Hz, ____ - phase, 3 wire and single phase, 2 wire. 2/3 steam jacketed, type 304 Stainless Steel kettle and supports. Jacket rated at 50 psi with Safety Valve, Permanently filled Steam Jacket, Splash Proof Solid State Temperature (±1° C) and Safety Control System in plug-in Module including L.E.D. indicators. Marine Lock. Optional Lift Off Cover.

DIMENSIONS

MODEL	A	B	C	D	E	F	G	H	J	K	L	M	N	Q	R
KET-3-T	20 1/4"	13 1/4"	6"	1 1/2"	14 1/2"	20"	18"	28 7/8"	12 7/8"	NA	32"	11"	6"	15 1/2"	17"
	(514mm)	(337mm)	(152mm)	(38mm)	(368mm)	(508mm)	(457mm)	(733mm)	(327mm)		(813mm)	(279mm)	(152mm)	(394mm)	(432mm)
KET-6-T	24"	17"	6 1/2"	1 1/2"	16 1/2"	22 1/2"	18"	28 1/2"	15 1/2"	6"	34"	13 1/4"	6"	17 1/4"	17"
	(610mm)	(432mm)	(165mm)	(38mm)	(419mm)	(572mm)	(457mm)	(724mm)	(394mm)	(152mm)	(864mm)	(337mm)	(152mm)	(438mm)	(432mm)
KET-12-T	27 1/2"	20"	7"	1 1/2"	19 1/8"	24 7/8"	18"	34"	16"	6"	38"	16 3/4"	6"	18"	17"
	(699mm)	(508mm)	(178mm)	(38mm)	(486mm)	(632mm)	(457mm)	(864mm)	(406mm)	(152mm)	(965mm)	(425mm)	(152mm)	(457mm)	(432mm)

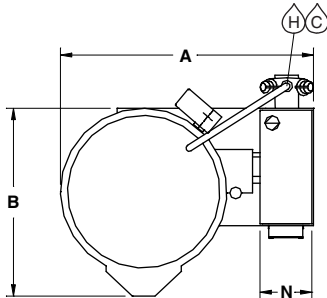

- CAPACITIES: (in 4 oz. servings, other sizes may be calculated)
 - 3 gallons / 11 liters 96 servings
 - 6 gallons / 23 liters 192 servings
 - 12 gallons / 45 liters 352 servings

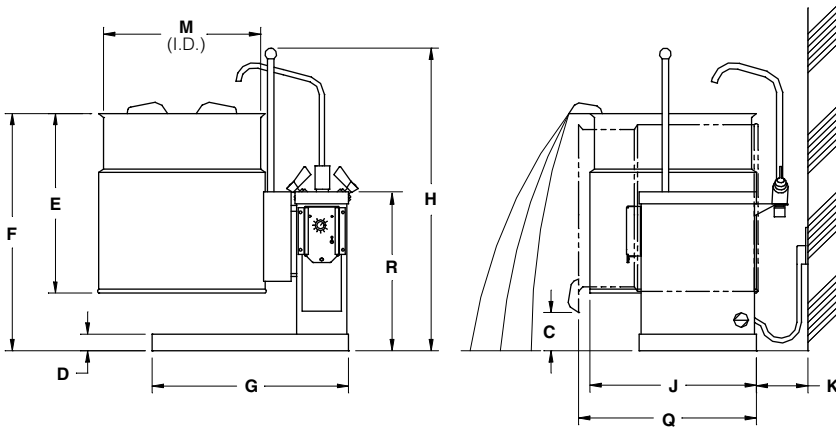

NOTE: SHOWN WITH
OPTIONAL DOUBLE PANTRY
FAUCET. CORD & PLUG
SUPPLIED BY OTHERS

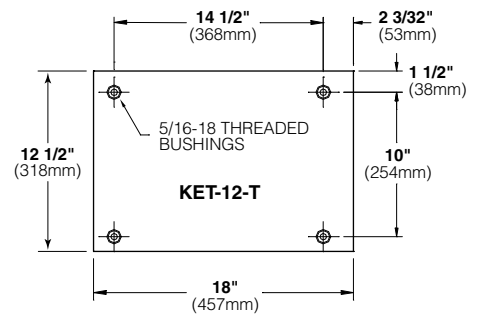
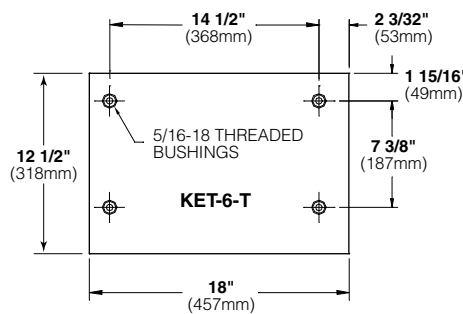
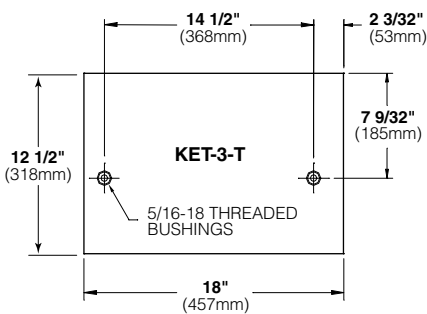

BASE MOUNTING DIAGRAMS

STANDARD WATTAGE

GALS. LITERS	208V			240V			415V			480V			
	KW	1PH	3PH	KW	1PH	3PH	KW	1PH	3PH	KW	1PH	3PH	
3	11	4.1	19.7	NA	5.4	22.7	NA	NA	NA	NA	NA	NA	
6	23	6.1	29.5	17.0	8.2	34.0	19.6	7.5	18.1	10.5	8.2	17.0	9.8
12	45	9.8	47.2	27.2	13.1	54.4	31.4	12.1	29.0	16.7	13.1	27.2	15.7

HIGH WATTAGE

GALS. LITERS	208V			240V			415V			480V			
	KW	1PH	3PH	KW	1PH	3PH	KW	1PH	3PH	KW	1PH	3PH	
6	23	9.8	47.2	27.2	13.1	54.4	31.4	12.1	29.0	16.7	13.1	27.2	15.7
12	45	12.3	59.0	34.1	16.3	68.1	39.3	15.1	36.2	20.9	16.3	34.0	19.6

Consult factory for other voltages.

NOTES:

Cleveland Range reserves right of design improvement or modification, as warranted.
Many regional, state and local codes exist and it is the responsibility of the owner and installer to comply with the codes.
Cleveland Range equipment is built to comply with applicable standards for manufacturers. Included among those approval agencies are U.L., NSF, CGA, CSA, ETL and others.

WATER

3/8" O.D. copper tube or
1/2" N.P.T. pipe.

When ordered with
optional faucet.

CLEARANCE

RIGHT = 0"

LEFT = 0"

REAR = See "K" on
chart above.