

### SteamCraft® Ultra 5

COUNTER TYPE DESIGN

PRESSURELESS CONVECTION STEAMER

GAS STEAM GENERATOR, 70,000 BTU

MODEL:  21-CGA-5

#### Cleveland Standard Features

- Cooking Capacity for up to five 12" x 20" x 2½" deep Cafeteria Pans (OR) 10 - 1" Cafeteria Pans.
- **Innovative PowerPak Gas Steam Generator:**
  - Naturally Fired 70 MBTU Generator is 72% Efficient
  - Strong 14 Gauge Stainless Steel Construction
  - Fully Automatic Electronic Spark Ignition (pilotless)
- **Simple ON/OFF Start Switch:** Ignites Burners and Water Fills into Pressureless Generator with ease.
- **Easy Access Cleaning Port:** Generator Cleaning Port located on the outside, top of the unit. Not necessary to remove hot panels or pan rack guides.
- **Generator Cleaning Light:** Indicator Light located on the front of the unit warns operator it is time to delime generator.
- **Steam Generator Stand By Mode:** Holds generator at a steaming temperature. Allows unit to start cooking instantly.
- **One 60 Minute Electro-Mechanical Timer and Switch for manual operation:** Audible signal for cooking time completion. (MCS)
- **4" Adjustable Legs.**
- **Durable 14 Gauge Stainless Steel Construction:** For compartment door, cavity, and steam generator.
- **Automatic Generator Drain with a "Water Jet" drain cleaning feature.**
- **Exclusive Automatic Remote Float Type Water Level Control:** Separate from the generator for easy access.
- **Exclusive Steam Cooking Distribution System:** Maintenance Free Exclusive Brass Steam Jets produce a high velocity convection steam without fans. Coved Corner design in cooking compartment distributes heat evenly, and is easy to keep clean. Creased top & bottom enhance drainage. Cold water condenser behind drain maintains a dry steam. Fully Insulated cooking compartment for thermal efficiency. Removable Stainless Steel Slide Racks for easy cleaning.
- **Exclusive "Cool to the Touch" Two-Piece Compartment Door Design:** Free floating inner door with reversible gasket provides an air tight seal. Stainless Steel Slam/Latch Door Latch mechanism for reliability.
- **Standard with Cord & Plug for 115 volt controls.**
- **Left Hand Door Hinging:** Compartment door hinged on left, controls on the right.

#### Options & Accessories

- Electronic Timer with Compensating Load Feature (ETC)
- Simple ON/OFF Switch for Compartment Controls (MC)



Shown with optional  
Electronic Timer

#### Short Form Specifications

Shall be CLEVELAND, SteamCraft® Ultra 5, one compartment, Counter-Type Steamer, Model 21-CGA-5, 70 M BTU, heavy duty all Stainless Steel construction; rear mounted, insulated Steam Generator with Remote Probe Type Water Level Controls and Automatic Steam Generator Blowdown with "Water Jet" Drain Cleaning feature.

- 34" (864mm) High Stainless Steel Economy Stand, for one 21-CGA-5 (UniStand34)
- POSK Pull-Out Shelf Kit for UniStand (P/N 111724)
- URK Pan Rack Kit UniStand (P/N 111726)
- Compartment Door Steam Shut Off (SCS)
- Cafeteria Pans in depths of 1", 2½", 4" and 6"
- Dissolve® Descale Solution, 6 one gallon container w/quart markings (106174)
- Propane Gas option (PG)
- Water Filters

### WATER QUALITY REQUIREMENTS

The quality of water varies greatly from region to region. Steam equipment generators must be drained daily and chemically descaled periodically to ensure proper operation. To minimize service problems caused by the accumulation of minerals and chemicals in water review the following quality guidelines with a local water treatment specialist. Inlet water that is beyond these specified guidelines should be treated to achieve these acceptable limits. Total Dissolved Solids less than 60 ppm, Alkalinity less than 20 ppm, Silica less than 13 ppm, pH factor greater than 7.5, Chlorine less than 30 ppm.

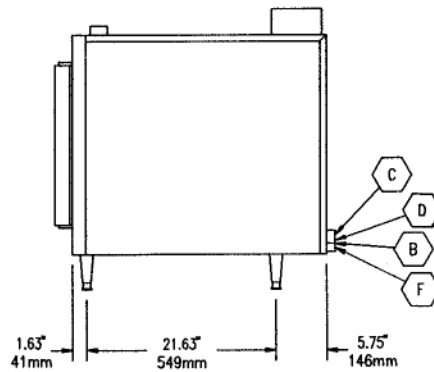
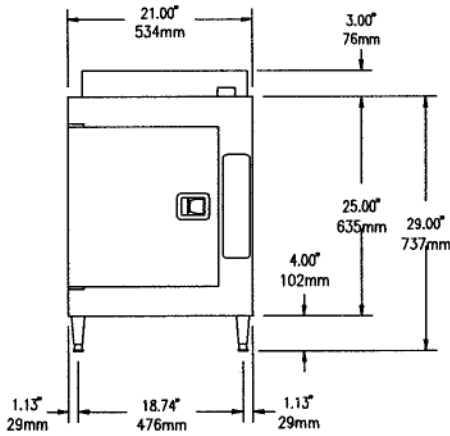
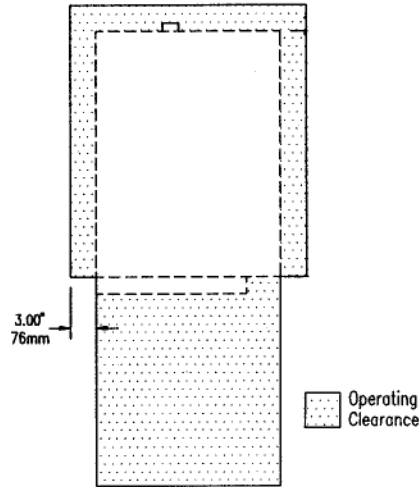
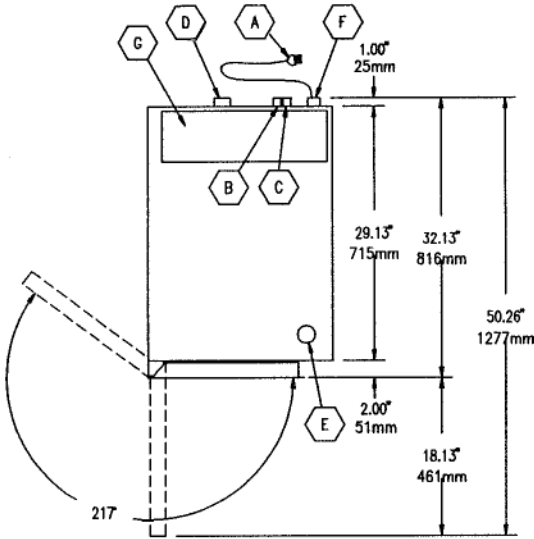

TOTAL CAPACITY	UTILITY CONNECTIONS		
5 — 12" x 20" x 2 1/2" Cafeteria Pans or 10 — 12" x 20" x 1" Cafeteria Pans or 3 — 12" x 20" x 4" Cafeteria Pans	(A) Electrical Supply	(D) Drain: 1-1/4" Dia. IPS	(G) Flue Gas Exhaust from Generator
	(B) Cold Water Supply for Condenser 1/4" Dia. NPT	(E) Inlet for Generator Deliming Solution	
	(C) Cold Water Supply for Generator. 1/4" Dia. NPT (for water treatment conn.) Unit comes with a 40 Mesh Water Strainer	(F) Gas Supply 1/2" Dia. IPS	

GAS	ELECTRIC	COLD WATER	DRAINAGE	CLEARANCE						
1/2" Dia. IPS  <table border="1"> <thead> <tr> <th colspan="2">SUPPLY PRESSURE</th> </tr> <tr> <th>NATURAL</th> <th>PROPANE</th> </tr> </thead> <tbody> <tr> <td>4.00" W.C. minimum 14.00" W.C. maximum</td> <td>12.00" W.C. minimum 14.00" W.C. maximum</td> </tr> </tbody> </table> Manufacturer must be notified if unit will be used above 2,000 ft. altitude.	SUPPLY PRESSURE		NATURAL	PROPANE	4.00" W.C. minimum 14.00" W.C. maximum	12.00" W.C. minimum 14.00" W.C. maximum	115V - 1 Phase 35 Watts 4 Amps	Cold water: 35 psi min., 60 psi max. Two 3/4" NH-F (Garden Thread) Connections. Use NSF approved hose. - one for Condenser - one for Steam Generator	1/4" Dia. IPS Do not connect any other units to this drain. Drain line must be vented. No PVC pipe for drain.	Right - 3", Left - 3", Rear - 3" (12" on control side if adjoining wall or equipment is over 30" high for service access)  <b>Contact factory for variances to clearances.</b>
SUPPLY PRESSURE										
NATURAL	PROPANE									
4.00" W.C. minimum 14.00" W.C. maximum	12.00" W.C. minimum 14.00" W.C. maximum									

#### NOTES:

Cleveland Range reserves right of design improvement or modification, as warranted. Many regional, state and local codes exist and it is the responsibility of the owner and installer to comply with the codes. Cleveland Range equipment is built to comply with applicable standards for manufacturers. Included among those approval agencies are UL/NSF#4 and CSA (AGA, CGA).

(NOT TO SCALE)  
 SECT. **IV** PAGE **8**  
 0411  
 Litho in U.S.A.