



Project _____
 Item _____
 Quantity _____
 FCSI Section _____
 Approval _____
 Date _____

THE "mini" COMBI OVEN-STEAMER

THE "mini" COMBI OVEN-STEAMER

ELECTRIC HEATED – Boilerless

Cooking Modes:

- Steam (86 - 248°F)
- Hot Air (86 - 482°F)
- "Delta T" slow cooking
- "Crisp & Tasty"
- Combi (212 - 482°F)
- Retherm (248 - 320°F)
- "Cook & Hold"

Convotherm Standard Features:

- Exclusive "Crisp & Tasty" de-humidifier feature
- "Press & Go" one step, recipe start buttons
- Requires minimum space - fits anywhere saving expensive floor space
- Boilerless injection system for steam
- Vented, double glass door with integrated door stop and self draining drip tray
- Tray Timer (time-delayed loading for each level)
- Easy to understand menu icons with bright graphics display
- Continuous self diagnostic system with full text message display
- Digital controls for temperature, time and core probe settings
- Advanced programmable start time for recipes
- Program up to 250 recipes with up to 20 steps each
- Exclusive "Smart Key" for selecting cooking option settings
- CONVOTHERM Cookbook with pre-programmed recipes
- Cook & Hold and Delta-T cooking
- Stores all device settings and recipes in an additional memory module (ID module)
- Multipoint core temperature probe
- Heavy duty stainless steel design
- Reliable door switch for long service life
- Heavy duty skid resistant 4" adjustable legs with flanged feet
- Oven light with shockproof glass cover
- Antibacterial two stage rotary lever door lock
- Two (2) speed auto reversing convection fan for even heat distribution

MODEL: OES 6.10 mini

CAPACITY: Three (3) – 13" by 18" half size sheet pans* or
 Three (3) – 12" x 20" by 2 1/2" steam table pans or
 Three (3) – 12" x 20" wire fry baskets

*The "mini" will hold six 13" x 18" half size sheet pans but is designed for optimal cooking results for three pans.

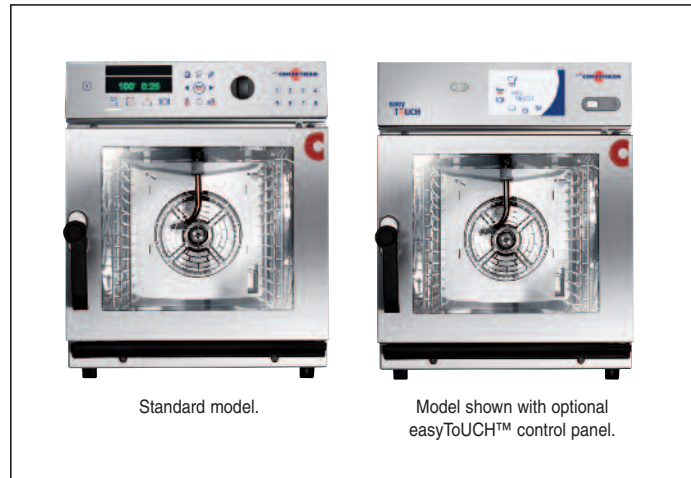

Standard model.

Model shown with optional easyToUCH™ control panel.

Short Form Specifications

Shall be Convotherm Model: OES 6.10 mini Combination Convection Oven / Steamer with simple to operate programmable controls for Hot Air, Convection, Steam, and Combination cooking modes, "Cook & Hold" and overnight slow-cooking capabilities, "Crisp & Tasty" de-humidifier feature. Multiple cooking stage programs, stored recipe library, multipoint core temperature probe, "Press & Go", one-step recipe start buttons, "Smart Key" for selecting option settings, boilerless. Capacity for three (3) – 12" x 20" by 2 1/2" steam table pans.

Options and Accessories

- easyToUCH™ control panel
- CONVOClean hands free automatic compartment washing system
- Open base stand with adjustable legs
- Smooth action hand shower for compartment cleaning
- Pressure spray bottle for manual cleaning
- CONVOClean compartment cleaning solution
- CONVOCare compartment rinse cycle solution
- 12" x 20" wire basket for frying products
- Chicken grill rack
- CONVOGrill Grilling Rack
- 12" x 20" Wire Shelves
- Water Treatment Systems
- Stackable stand for double stacked units

Click here to buy now!



1-866-285-1252

SECT. IIA PAGE 59
0613



NOTE:

The owner / operator / purchaser must ensure that the drinking/potable water quality requirements are met. Not meeting the water quality requirements will void the original equipment warranty.

Water Quality Requirements:

TDS	50-125 ppm	pH Factor	7.0-8.5
Total Alkalinity	50-100 ppm	Free Chlorine	< 0.1 ppm
Silica	< 13 ppm	Hardness	50-100 ppm (3<6 gpg)
Chloride	< 25 ppm	Water Pressure	35-80 psi

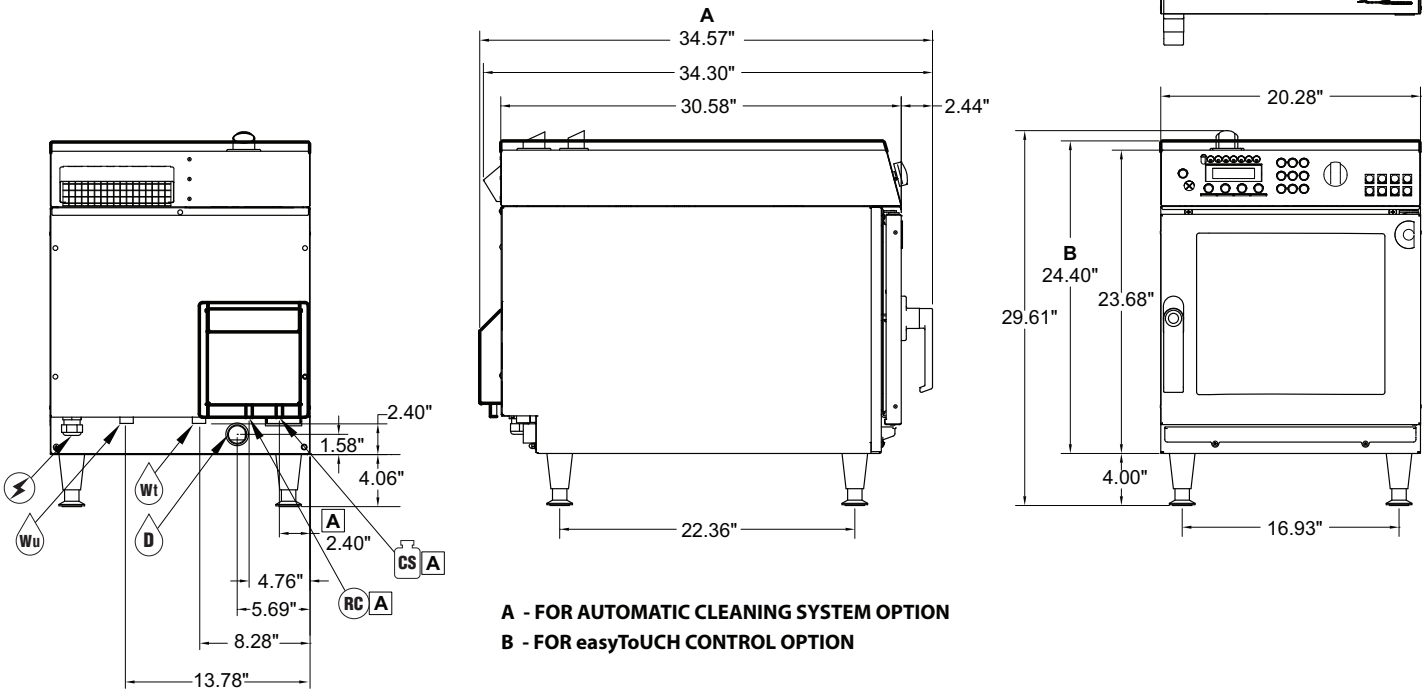
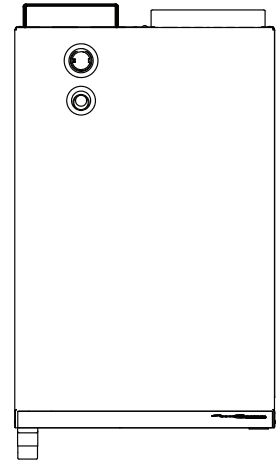

A - FOR AUTOMATIC CLEANING SYSTEM OPTION
B - FOR easyToUCH CONTROL OPTION

ELECTRICAL CONNECTIONS

The 3 phase 208-240 volt units will be supplied with a 10 AWG, SOOW, 4 conductor 6 foot long cord. The customer will have to provide the NEMA plug (NEMA # 15-30P or L15-30P). Unit current rating 17.9 amps.

The 1 phase 208-220 volt units will be supplied with a 10 AWG, SOOW, 3 conductor 6 foot long cord. The customer will have to provide the NEMA plug (NEMA # 6-30P or L6-30P). Unit current rating 22.7 amps.

The 1 phase 240 volt units will be supplied with a 10 AWG, SOOW, 3 conductor 6 foot long cord. The customer will have to provide the NEMA plug (NEMA # 6-50P or L6-50P). Unit current rating 24.5 amps.

These units cannot be hard wired to the circuit box. They must have a NEMA plug to be connected to a mating NEMA receptacle (customer supplied) to comply with the U.L. and NEC electrical standards.

AGENCY APPROVALS



NOTES:

Convotherm reserves right of design improvement or modification, as warranted. Many regional, state and local codes exist and it is the responsibility of the owner and installer to comply with the codes. Convotherm equipment is built to comply with applicable standards for manufacturers.

COLD WATER CONNECTION

- Wt** One 3/4" GHT (Garden Hose Thread) connection for treated potable water.
 - Wu** One 3/4" GHT (Garden Hose Thread) connection for untreated potable water.
- Use NSF approved hose. 35 PSI minimum, 80 PSI maximum.

DRAIN CONNECTION

1 1/2" Tube. Do not connect other units to this drain. Drain line must be vented.

CS CONNECTION FOR CONVOClean CLEANING SOLUTION (Available as an option)

RC CONNECTION FOR CONVOCare RINSE SOLUTION (Available as an option)

SERVICE CLEARANCES

3" left, 3" right, 3" rear, allow 20" on top for service. Allow for sufficient distance if a "high heat source" (i.e. Broiler) is located next to the unit.

SHIPPING WEIGHT

190 lbs.