

STEAMCRAFT® GENERATOR STYLE HIGH SPEED CONVECTION STEAMERS

Project _____
 Item _____
 Quantity _____
 FCSI Section _____
 Approval _____
 Date _____

SteamCraft® Gemini™ 10 TWO COMPARTMENT FLOOR MODEL DESIGN PRESSURELESS CONVECTION STEAMER TWIN, INDEPENDENT GAS-FIRED GENERATORS

MODEL: 24-CGA-10.2

Cleveland Standard Features

- Cooking Capacity for up to ten 12" x 20" x 2 1/2" deep Cafeteria Pans, five each compartment.
- Totally independent cooking compartments, each has its' own generator, gas valve and water level controls - no shared components
- Exclusive High Efficiency Gas Power Burner (forced air) Generator: Produces more steam for faster cooking while lowering operating costs (72M BTU's per compartment)
- Easy Access Cleaning Port: Each generator has a delimiting port located on the outside, top of the unit
- Generator Steam Standby Mode: Holds generator at a steaming temperature, allows unit to start cooking quickly
- Each compartment has one, 60-Minute Electro-Mechanical Timer with "SureCook" load compensating feature. Manual Bypass Switch for constant steaming.
- Durable 14 Gauge, 304 Stainless Steel construction for compartment door, cooking cavity and steam generator
- Exclusive Two-Piece Compartment door: Slammable, self-adjusting door provides and airtight seal, reversable door gasket for extended life
- Exclusive Gemini Drain/Power Control System: Simple, reliable 1/2" ball valve style drain automatically turns power ON/OFF
- Exclusive Brass Steam Jets distribute even-high velocity steam throughout cooking compartment for faster cooking times
- Easy, Front -Access Generator Controls comes with a pullout drawer for simple servicing of unit
- 6" Stainless Steel Adjustable Legs with Flanged Feet
- Approvals: CSA (AGA, CSA) and U.L/NSF#4
- Compartment Steam Shut-Off Switch when compartment door is opened



Short Form Specifications

Shall be Two Compartments, Cleveland Convection Steamer series SteamCraft® Gemini™ 10, Model 24-CGA-10.2, Twin Gas Atmospheric Steam Generator, 72M BTU's input per compartment. Independent steam generator, gas valve and water level control system. Automatic Generator Blowdown. Steam Generator with Automatic Water Fill on start up. Exclusive remote probe-type water level controls. Exclusive Brass "Steam Jet" distribution system. Two-piece free-floating compartment door. Type 430 Stainless Steel exterior and cooking compartments. Pullout service drawer for controls and Gemini Drain/Power Control System. Exclusive Cold Water Condenser design. Choice of Compartment Controls. Manual By Pass for continuous steaming.

markings (106174)

- Water Filters

Options & Accessories

- Electronic Timer with Compensating Feature (ETC)
- On/Off Steam Switch Controls, no timer (MC)
- Propane Gas (PG)
- Dissolve® Descale Solution, 6 one gallon container w/quart

SECT. IV PAGE 13A
0612

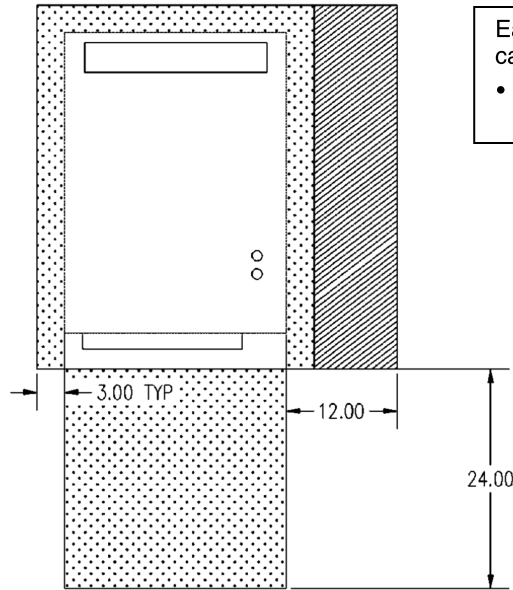
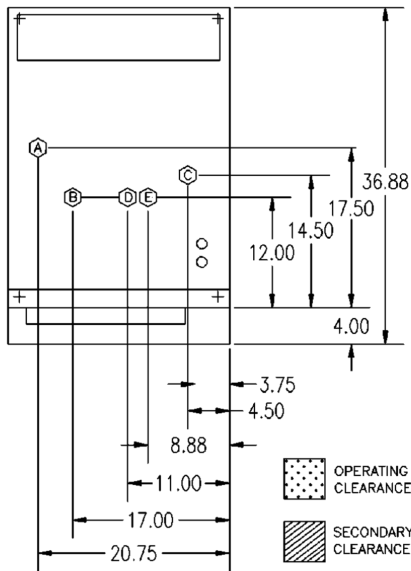

Each Compartment has capacity for:

- Five, 12" x 20" x 2½" deep Cafeteria Pans.

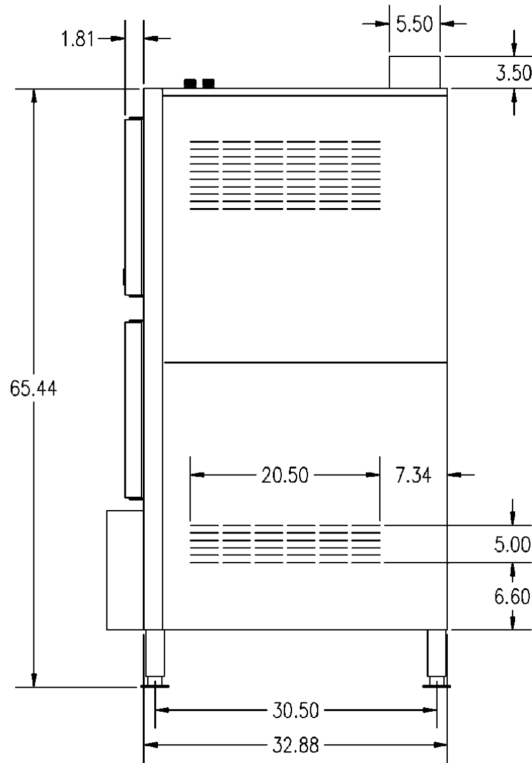
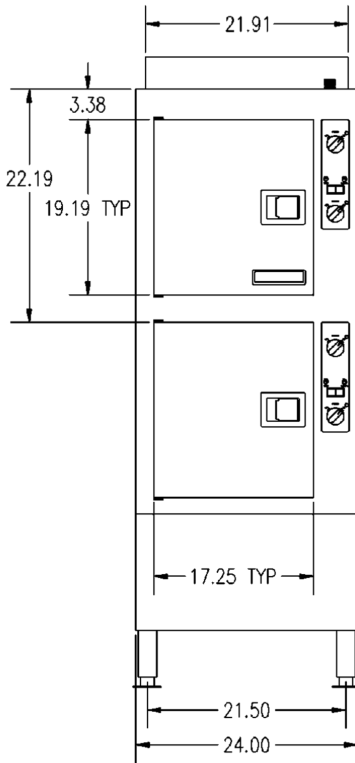

WATER QUALITY REQUIREMENTS

The quality of water varies greatly from region to region. Steam equipment generators must be drained daily and chemically descaled periodically to ensure proper operation. To minimize service problems caused by the accumulation of minerals and chemicals in water review the following quality guidelines with a local water treatment specialist. Inlet water that is beyond these specified guidelines should be treated to achieve these acceptable limits. Total Dissolved Solids less than 60 ppm, Alkalinity less than 20 ppm, Silica less than 13 ppm, pH factor greater than 7.5, Chlorine less than 30 ppm.

Ⓐ GAS			Ⓑ ELECTRIC	Ⓒ COLD WATER	CLEARANCE	Ⓓ DRAINAGE
1½" IPS line size, ¾" connection			120V-1Phase, 60 Hz.	35 psi minimum	Right - 3", Left - 3", Rear - 3"	1½" dia.
NATURAL	PROPANE	BTU	2 Blowers & Controls	60 psi maximum	(12" on control side if adjoining wall or equipment is over 30" high for service access)	Do not connect other units to this drain
Piping ¾" N.P.T.	Piping ¾" N.P.T.	72,000 each	150 watts each	One (E) 3/8" dia. NPT for Generator	Contact factory for variances to clearances.	Drain must not be located beneath the steamer itself
Supply pressure 4.50" W.C. Min.	Supply pressure 11.00" W.C. Min.	Generator, 144,000 total	** Do not connect to GFI outlet. See note below.	One (D) 3/8" dia NPT for Condenser		Preferred floor drain location should be a minimum distance (from the unit) of at least 12" from the left side, 12" from the right side, 6" from the front and 6" from the rear.
14.00" W.C. Max.	14.00" W.C. Max.					Do not use PVC pipe
Manufacturer must be notified if unit will be used above 2,000 feet						

NOTES:
 **DO NOT CONNECT TO GFI OUTLET. CLEVELAND RANGE RECOMMENDS GAS FIRED 120 VOLT STEAMERS BE HARD WIRED DIRECTLY TO ELECTRICAL SYSTEM. Cleveland Range reserves right of design improvement or modification, as warranted. Many regional, state and local codes exist and it is the responsibility of the owner and installer to comply with the codes. Cleveland Range equipment is built to comply with applicable standards for manufacturers. Included among those approval agencies are UL/NSF#4 and CSA (AGA, CGA).