

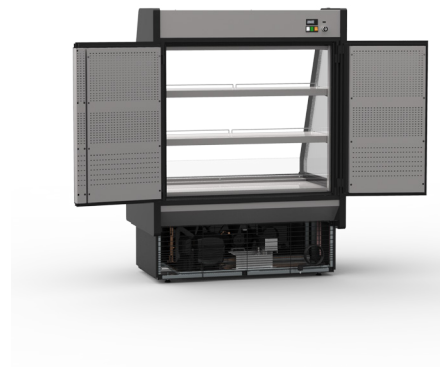

ELECTRIC SHUTTER



REAR LOADING

## MODELS

KGL-RS-(40, 60)-S

KGL-RS-(40, 60)-R

## GRAB-N-GO LOW PROFILE CASE FRONT AND REAR LOADING, ELECTRIC SHUTTER

CASE HOLDS 38°F TO 40°F • FORCED AIR REFRIGERATION • OPEN FRONT  
FRONT AND REAR LOADING • KEY OPERATED ELECTRIC SHUTTER • TEMPERATURE RECORDER



AVAILABLE WITH A BLUE DECAL  
\*CONTACT OUR SALES DEPARTMENT FOR MORE INFORMATION



AUTODESK®  
REVIT®

SELF CONTAINED	Model	O.A. Length (inches)	Volume FT <sup>3</sup>	Electrical 115 Volts					NEMA 115 V Plug	Weight lbs		Crate Size (inches)			
				Front	Compressor		LIGHTS Fans HTRS	EVAP Pan		Total Amps	No Crate	With Crate	L"	W"	H"
					H.P	F.L.A									
	KGL-RS-40-S	41	12.98	5/8	8.9	2.32	6.7	16.8	5-20P	419	585	44	39	74	
	KGL-RS-60-S	60.6	19.85	3/4	16	3.45	6.7	25	-	510	750	64	39	74	

REMOTE	Model	O.A. Length (inches)	115 Volts Total Amps	B.T.U	Weight lbs	
					No Crate	With Crate
					KGL-RS-40-R	41
KGL-RS-60-R	60.6	1.4	5835	430	635	

**SPECIAL FEATURES**

- Locking back doors for rear loading
- Key operated electric shutter
- Digital temperature data logger
- Graphics on upper and lower front panels

**STANDARD FEATURES**

- Silver colored PVC coated steel front panel with a blue decal
- CFC free injected foam insulation
- PVC coated steel gray interior
- Black steel kick plate
- Foamed polystyrene black end panels
- Tempered side glass
- LED lighting in canopy and under shelves
- Temperature and defrost regulated by a digital controller
- Slide out condensing unit on self-contained units
- Removable condensate evaporating pan for easy cleaning
- Product stops on all shelves
- Height adjustable, shelves can be tilted
- Levelling feet

**OPTIONAL FEATURES**

- Stainless steel exterior and / or interior
- Other colors available
- Additional shelves
- Price tag molding
- Product dividers
- Condensate evaporating pan for remote cases
- Stainless steel legs are adjustable from 5-1/8" to 7-5/8"
- KGL-RS caster kit

**WARRANTY**

One year parts and labor with an additional four years on the compressor (part only)

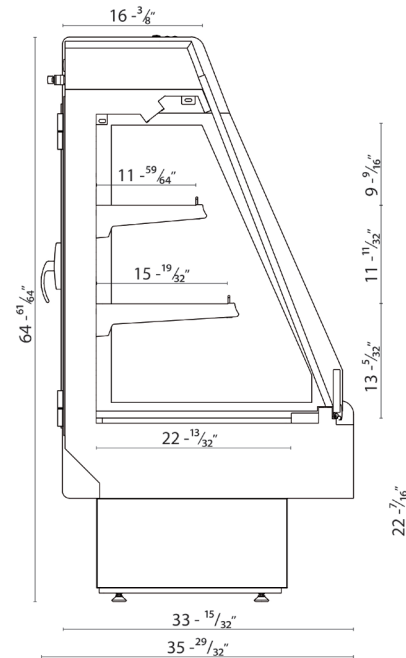

**NOTE**

These cases are engineered to operate in locations not exceeding 75°F and 55% R.H. These cases are designed to operate using R404a refrigerant. Alternate refrigerants available by special order. O.A. length includes (2) ends at 1-1/2" each. Ventilation grills at front and back cannot be blocked. B.T.U.'s are calculated at 14°F (evaporator) and 90°F (ambient). Remote cases are provided with an expansion valve and a liquid solenoid for pump down cycle. On remote cases, if no floor drain is provided, a condensate evaporating pan must be ordered and 6.7 amps added to the amp load. Remote cases must be hard wired – no plugs.