



MODELS

KGL-OU-(48)

COMBINATION TYPE CASE

CASE HOLDS 36°F TO 40°F • UPPER SECTION CAN BE OPERATED AS REFRIGERATED OR DRY
MULTIPLE USES • FORCED AIR REFRIGERATION • OPEN FRONT LOWER SECTION
FRONT LOADING LOWER SECTION • TEMPERED GLASS,
REAR SLIDING DOORS IN UPPER SECTION



AUTODESK[®]
REVIT[®]

SELF CONTAINED	Model	O.A. Length (inches)	Volume FT ³	Electrical					Weight lbs		Crate Size (inches)		
				Compressor		LIGHTS Fans HTRS	Evap PAN	Total Amps 115 V	No Crate	With Crate	L"	W"	H"
				H.P	F.L.A 115V								
	KGL-OU-48-S	48.03	11	3/4	16	1.33	6.67	24	564	708	53	40	71

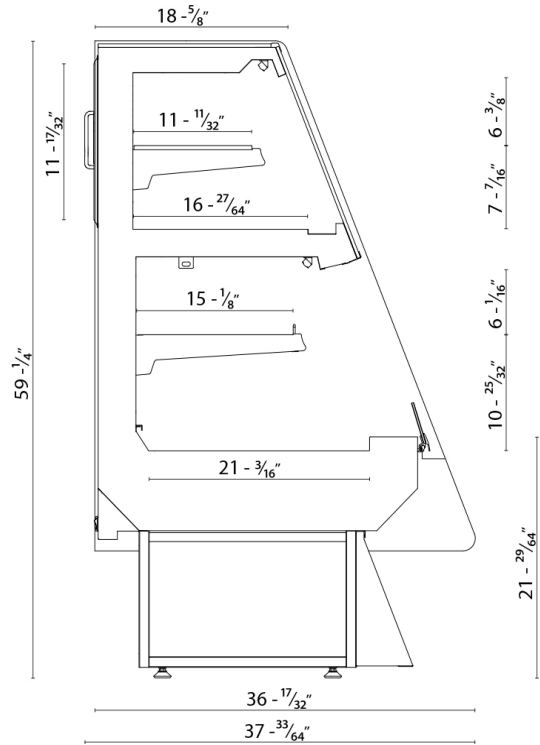

STANDARD FEATURES

- CFC free injected foam insulation
- Silver colored PVC coated steel front panel
- PVC coated steel gray interior
- Wood laminate covered end panels
- LED lighting in canopy and under all shelves
- Height adjustable shelves can be tilted
- Temperature and defrost regulated by a digital controller
- Removable condensate evaporating pan for easy cleaning
- Slide out condensing unit on self-contained units

OPTIONAL FEATURES

- Stainless steel front panel
- Stainless steel base and / or interior
- Mirror rear sided doors (upper section)
- Mirrored side glass
- Front panel bumper protector
- PVC coated gray steel folding rear shelf
- Stainless steel folding rear shelf
- Acrylic product partitions
- Shelf price tag moldings
- Casters add 4-3/8" to height
- Stainless steel legs are adjustable from 5-1/8" to 7-5/8"
- Please specify grey or white when ordering

Standard Mounting



Levelling Feet

Optional Mounting



Adjustable Legs



Casters

NOTE

These cases are engineered to operate in locations not exceeding 75°F and 55% R.H. These cases are designed to operate using R404a refrigerant. Alternate refrigerants available by special order. Ventilation grills at front and back cannot be blocked. B.T.U.'s are calculated at 14°F (evaporator) and 90°F (ambient).

WARRANTY

One year parts and labor with an additional four years on the compressor (part only)



Tel: 786.600.4687 / Toll Free: 844.218.8477

Fax: 786.661.4100



Tel: 514.737.9701 / Toll Free: 888.275.4538

Fax: 514.342.3854 / toll free: 877.453.8832

sales@mvpgroupcorp.com / mvpgroupcorp.com

