



Foodservice Equipment

Job _____ Item# _____

Lava Rock Gas Charbroilers

TMLC24, TMLC36, TMLC48

Radiant Style Gas Charbroilers

TMRC24, TMRC36, TMRC48

Standard Features:

- Available in 24", 36" and 48" widths.
- Stainless steel front including top rail.
- 30,000 BTU per foot.
- Aluminized steel drip pan, rear and sides.
- Adjustable flame per 12" cooking zone.
- Reversible double branding grates.
- Narrow grates have drain channels.
- Full width water pan for easy cleaning.
- Radiant units are designed with stainless steel radiantss.
- Lava rock units include 1 bag of lava rock per 12" section.
- 4" nickel plated steel legs.
- 3/4" rear gas connection.



TMLC36

Applications:

Toastmaster's Countertop Gas Charbroilers are the most economical and flexible countertop charbroiler in the food service industry. They offer unsurpassed performance, combining a proven control system with Toastmaster quality and durability. Available in three different sizes - 24", 36" and 48".

General Information:

Stainless steel front includes top rail, with aluminized steel rear and sides. Full width water pan,

reversible grates and 30,000 BTU per foot burners.

Warranty:

Toastmaster charbroilers are covered by Toastmaster's one year parts and labor warranty.



T103/0119

Lava Rock Gas Charbroilers

TMLC24, TMLC36, TMLC48

Radiant Style Gas Charbroilers

TMRC24, TMRC36, TMRC48

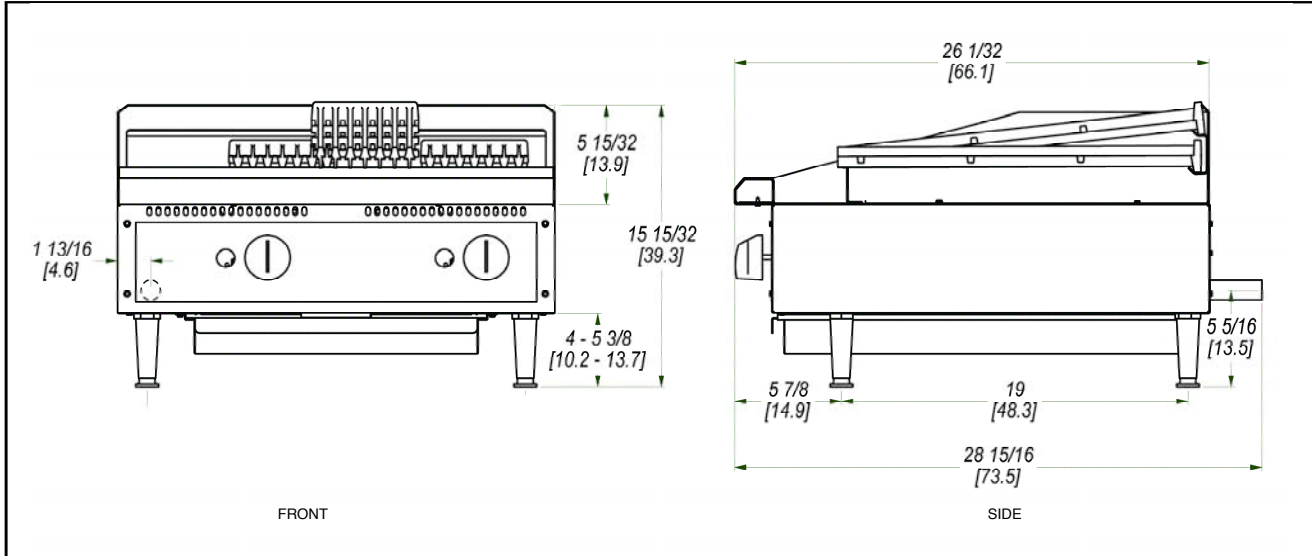

| Model Number | TMLC24 | TMLC36 | TMLC48 | TMRC24 | TMRC36 | TMRC48 |
|-------------------------------------|--|--|--|--|--|--|
| Dimensions | 24" W x 15-15/32" H x 26-1/32" L | 36" W x 15-15/32" H x 26-1/32" L | 48" W x 15-15/32" H x 26-1/32" L | 24" W x 15-15/32" H x 26-1/32" L | 36" W x 15-15/32" H x 26-1/32" L | 48" W x 15-15/32" H x 26-1/32" L |
| Number of Controls | 2 | 3 | 4 | 2 | 3 | 4 |
| BTU | 60,000 | 90,000 | 120,000 | 60,000 | 90,000 | 120,000 |
| Griddle Plate Thickness | 5/8" | 5/8" | 5/8" | 5/8" | 5/8" | 5/8" |
| Cook Zone Size | 24" | 36" | 48" | 24" | 36" | 48" |
| Installed Weight (lbs.) (kg) | 153 lbs. (69.5) | 192 lbs. (87.2) | 299 lbs. (135.7) | 153 lbs. (69.5) | 192 lbs. (87.2) | 299 lbs. (135.7) |
| Shipping Weight (lbs.) (kg) | 186 lbs. (84.4) | 230 lbs. (104.4) | 350 lbs. (158.9) | 186 lbs. (84.4) | 230 lbs. (104.4) | 350 lbs. (158.9) |

Typical Specifications:

Gas charbroilers are constructed with stainless steel front panel and reinforced aluminized steel side panels. Every 12" (30.5 cm) an individually controlled, corrosion resistant, burner supplies up to 30,000 BTU/hr (8.8Kw) of heat. Cooking surface is heavy-duty cast iron with two grid mark widths on opposite sides. Cooking surface can be adjusted for level or slanted grilling. Standing pilot is provided. A full width water pan is provided. Control knobs are protected by a stainless steel bull nose front. Char-broilers are supplied with 4" (10.2 cm) high die cast nickel plated legs with a 1-3/8" (3.5 cm) adjustment. Gas connection is 3/4" N.P.T. (male) and a convertible regulator is supplied as well as a kit for conversion to LP gas. Units are UL Gas Certified for U.S. and Canada. UL listed to NSF4 standard. Printed in the U.S.A.

INTENDED FOR COMMERCIAL USE ONLY. NOT FOR HOUSEHOLD USE.



Toastmaster, in line with its policy to continually improve its product, reserves the right to change materials or specifications without notice. Such revisions do not entitle the buyer to corresponding changes, improvements, additions, or replacements for previously purchased equipment.



Toastmaster® 10 Sunnen Dr, St. Louis MO 63143 • www.toastmastercorp.com
Toll Free: 1-800-264-7827 • Telephone: 1-314-781-2777 • Fax: 1-314-781-3636