



# U Series 36" Gas Restaurant Range

Item: \_\_\_\_\_  
 Quantity: \_\_\_\_\_  
 Project: \_\_\_\_\_  
 Approval: \_\_\_\_\_  
 Date: \_\_\_\_\_

U Series 36" Gas Restaurant Range

### Models:

- |                                 |                                    |                                    |                                   |
|---------------------------------|------------------------------------|------------------------------------|-----------------------------------|
| <input type="checkbox"/> U36-6R | <input type="checkbox"/> U36-4G12R | <input type="checkbox"/> U36-2G24R | <input type="checkbox"/> U36-G36R |
| <input type="checkbox"/> U36-6S | <input type="checkbox"/> U36-4G12S | <input type="checkbox"/> U36-2G24S | <input type="checkbox"/> U36-G36S |



Model U36-6R

NOTE: Ranges supplied with casters must be installed with an approved restraining device.

### Standard Features:

- Large 27" (686mm) work top surface
- Stainless steel front and sides
- Stainless steel 5" (127mm) plate rail
- Stainless steel backguard, w/removable stainless steel shelf
- 12" (305mm) section stamped drip trays w/ dimpled bottom
- 6" (152mm) adj. stainless steel legs
- Large easy-to-use control knobs
- Gas regulator

### Standard on Applicable Models:

- Cabinet base in lieu of oven, suffix S
- Ergonomic split cast iron top ring grates
- Powerful 32,000 Btuh/ 9.37 kW 2 piece cast iron geometric open top burner
- 5/8" (15mm) thick steel griddle plate w/manual hi/lo valve control, 23" (584mm) working depth surface, Standard on right, optional on left
- 4-1/4" (108mm) wide grease trough
- 18,000 Btuh/5.27 kW cast iron "H" style griddle burner per 12"(305mm) width of griddle
- 38,000 Btuh/ 11.13 kW cast iron "H" style oven burner
- Snap action modulating oven thermostat low to 500° F
- Large porcelain ribbed oven bottom & door, aluminized steel top, sides and back; oven fits standard sheet pans in both directions for standard ovens
- Strong, keep-cool oven door handle

- Nickel plated oven rack and 3-position removable oven rack guide
- Convection oven w/3 nickel plated oven racks and removable rack guides in lieu of standard oven w/ 1/3HP 120v 60 Hz single phase fan motor; change suffix R to C

### Optional Features:

- Convection oven motor 240v 50/60HZ single phase
- Snap action modulating griddle control 175° to 425° F
- Grooved griddle in 1/2 or full plate section widths
- Hot top 12" (305mm) plate in lieu of two open burners, manual valve controlled w/18,000 Btuh/5.27 kW cast iron "H" burner standard on left side
- Low profile 9-3/8" (238mm) backguard stainless steel front and sides
- Stainless steel back for high shelf, low profile backguard or range
- Additional oven racks
- 6" (152mm) levelling swivel casters (4), w/front locking
- Flanged deck mount legs
- Two stainless steel doors for storage base models
- Intermediate stainless steel shelf for storage base models
- Celsius temperature dials

### Specifications:

Gas restaurant series range with large capacity (standard) oven. 35 7/16" (900mm) wide with a 27" (686mm) deep work top surfaces. Stainless steel front, sides and 5" wide front rail. 6" (152mm) legs with adjustable feet. Six powerful 2 piece 32,000 Btuh/9.37 kW (Natural Gas), cast open burners set in split cast iron ergonomic grates. Griddle or optional hot-top with cast iron "H" style burners, 18,000 Btuh/5.27 kW (natural gas), in lieu of open burners. Porcelain oven bottom and door

liner. Durable heavy duty oven door w/ "keep cool" handle. Heavy cast iron "H" oven burner rated 38,000 Btuh/11.13 kW (natural gas) Oven controlled by even bake, fast recovery snap action modulating oven thermostat. Available with convection oven or storage base in lieu of standard oven.



Garland  
 1333 East 179th Street  
 Cleveland, Ohio 44110  
 Phone: 800-424-2411  
 Fax: 800-624-0218

Garland Commercial Ranges Ltd  
 1177 Kamato Road,  
 Mississauga, Ontario  
 L4W 1X4 CANADA  
 Phone: 905-624-0260  
 Fax: 905-624-5669



Model Number	Description	Total BTU/Hr Natural	Shipping Information		
			Lbs.	Kg	Cu Ft <sup>2</sup>
U36-6R <sup>1</sup>	Six Open Burners w/26" Oven	230,000	430	195	37
U36-6S	Six Open Burners w/Storage Base	192,000	310	141	37
U36-4G12R <sup>1</sup>	12" Griddle, Four Open Burners w/26" Oven	184,000	460	209	37
U36-4G12S	12" Griddle, Four Open Burners w/Storage Base	146,000	340	154	37
U36-2G24R <sup>1</sup>	24" Griddle, Two Open Burners w/26" Oven	138,000	495	225	37
U36-2G24S	24" Griddle, Two Open Burners w/Storage Base	100,000	375	170	37
U36-G36R <sup>1</sup>	36" Griddle w/26" Oven	92,000	530	240	37
U36-G36S	36" Griddle w/Storage Base	54,000	410	186	37

<sup>1</sup> Available with convection oven change R to C    <sup>2</sup> Ranges with convection ovens "C" are 57 Cu Ft

Width In (mm)	Depth <sup>3</sup> In (mm)	Height w/shelf In (mm)	Oven Interior-in (mm)			Combustible Wall Clearance-In (mm)		Entry Clearances In (mm)		Manifold Operating Pressure	
			Height	Depth <sup>4</sup>	Width	Sides	Rear	Crated	Uncrated	Natural	Propane
35-7/16 (900)	34-1/2 (876)	57 (1448)	13 (330)	26 (660)	26-1/4 (667)	14 (356)	6 (152)	37 (940)	36-1/2 (927)	4.5" WC 11 mbar	10" WC 25 mbar

<sup>3</sup> Convection oven base models add 3 7/8" (98mm) to the depth of the unit.    <sup>4</sup> Convection oven depth 22" (559mm)  
 Gas input ratings shown for installations up to 2000 ft.,(610m) above sea level. Please specify altitudes over 2000 ft.

Burner Ratings (BTU/Hr/kW)			
Gas Type	Open Top	Griddle/ Hot Top	Standard Oven or Convection
Natural	32,000/9.37	18,000/5.27	38,000/11.13
Propane	26,000/7.61	18,000/5.27	32,000/9.38

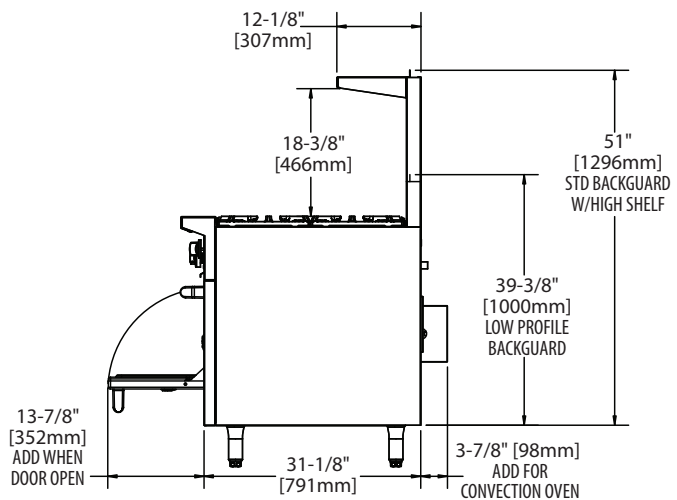
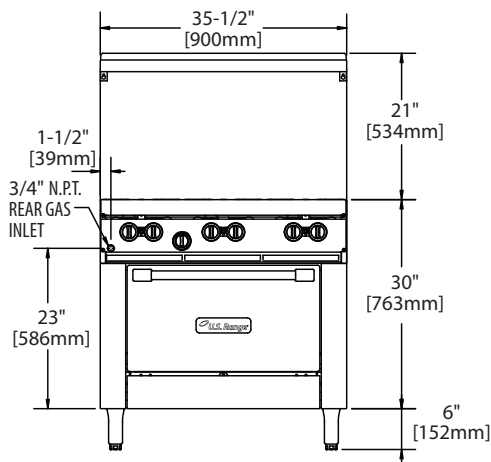
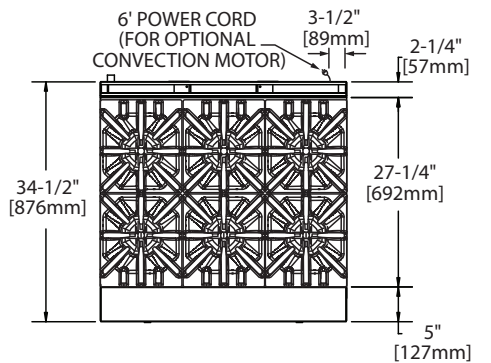

Note: Installation clearance reductions are applicable only where local codes permit.

This product is not approved for residential use.

Convection ovens with 120V, 60 Hz, 1 phase, 3.4 amps motors are supplied with 6'/1829mm cord and plug (NEMA 5-15P); 240V, 50/60 Hz, 1 phase motors are not supplied with cord and plug and must have direct connect.

Form# U36 Series (01/04/11)

Garland  
 1333 East 179th Street  
 Cleveland, Ohio 44110  
 Phone: 800-424-2411  
 Fax: 800-624-0218

Garland Commercial Ranges Ltd  
 1177 Kamato Road,  
 Mississauga, Ontario  
 L4W 1X4 CANADA  
 Phone: 905-624-0260  
 Fax: 905-624-5669

