



Master Series Heavy Duty Upright Broiler

Item: _____
 Quantity: _____
 Project: _____
 Approval: _____
 Date: _____

Master Series Heavy Duty Upright Broiler

Models:

- M60XR M60XS

Ceramic Broiler with Upper Finishing oven



Model M60XS

Standard Features:

- Stainless steel front; black powder coat epoxy sides
- 6" (152mm) chrome steel adjustable legs
- 7-1/2" (191mm) stainless steel front rail
- Porcelain interior finishing oven
- Two large cast iron multi-jet burners, 80,000 BTU (23.44 kW) total, (natural gas)
- Removable broiler grid
- 5 position adjustable rack
- On/Off control for broiler
- Piezo spark ignition for oven
- Fully porcelainized oven interior
- 40,000 BTU (11.72 kW - natural gas)/35,000 BTU (10.25kW - propane) cast iron oven burner

- Stainless steel main back
- Convection oven base, add C to Model No., e.g. M60XRC
- Additional oven rack
- Rear gas connection, 1-1/4" NPT (battery installation), 3/4" NPT (stand-alone installation)
- End caps and cover (NC- Specify)
- Swivel casters (4) w/front brakes
- Polyurethane non-marking swivel casters (4) w/front brakes
- 6" (152mm) stainless steel adjustable legs
- Toe base or curb mount (not for use with "RC" oven)
- Storage cabinet with doors
- 230 volt, 50 cycle components, RC motor (export)
- Celsius dial for oven thermostat (NC)

Optional Features:

- Stainless steel left, right or both sides

Specifications:

Heavy-duty gas ceramic broiler with oven and upper finishing oven, Model #M60XR. Two 40,000 BTU (11.72 kW) large cast iron multi-jet burners. Adjustable broiler rack with removable grid. Porcelain enamel oven interior with 40,000 BTU (11.72 kW) cast iron oven burner. Stainless steel front with black powder coat epoxy sides. 120,000 BTU (35.16 kW) total. Natural or propane gas. Also available with storage base w/ doors, M60XS.



NOTE: Broilers supplied with casters must be installed with an approved restraining device.

Garland Commercial Ranges Ltd
 1177 Kamato Road,
 Mississauga, Ontario
 L4W 1X4 CANADA
 Phone: 905-624-0260
 Fax: 905-624-5669



Product	Width: In(mm)	Depth: In(mm)	Height: In(mm) (w/ NSF Legs)	Oven/Storage Base Interior: In(mm)			Shipping Wt: (Lb/Kg) – Cu F
				Width	Depth	Height	
M60XR	34(864)	38(965)	72-1/8(1831)	26-1/4(667)	29(737)	13-1/2(343)	750/341 – 70
M60XS	34(864)	38(965)	72-1/8(1831)	26(665)	30-1/2(773)	20-1/2(519)	650/295 – 70

INPUT-BTU/hr (Natural Gas)	M60XR	kW Equivalent	M60XS	kW Equivalent
Top Section	80,000	23.44	80,000	23.44
Oven	40,000	11.72	N/A	–
TOTAL	120,00	35.16	80,000	23.44

RC=Range w/Convection Oven R=Range w/Oven S=Range w/Storage Base

INSTALLATION NOTES		
Combustible Wall Clearances ¹	Entry Clearances	Operating Pressure
Sides: 6" (152mm) Back: 6" (152mm)	Crated: 39-1/4" (997mm) Uncrated: 34-1/4" (870mm)	Natural: 6" WC (15mbar) Propane: 11" WC (28mbar)

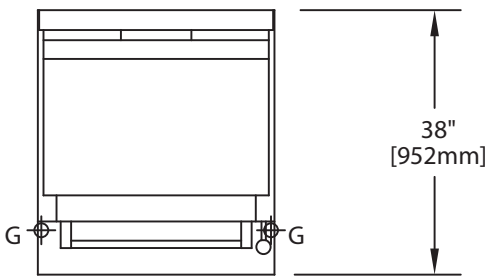

¹NOTE: Installation clearance reductions are applicable only where local codes permit.

Data applies only to North America

Gas input ratings shown here are for installations up to 2,000 Ft. (610m) above sea level. Specify altitudes over 2,000 Ft.

Electrical characteristics each RC oven: 1/3 HP motor, 120 VAC, single phase, 3.4 amps, 6 ft. (1.8m) power supply cord provided. 230 VAC export is direct connect, single phase, 50 Hz.

Please specify gas type when ordering.

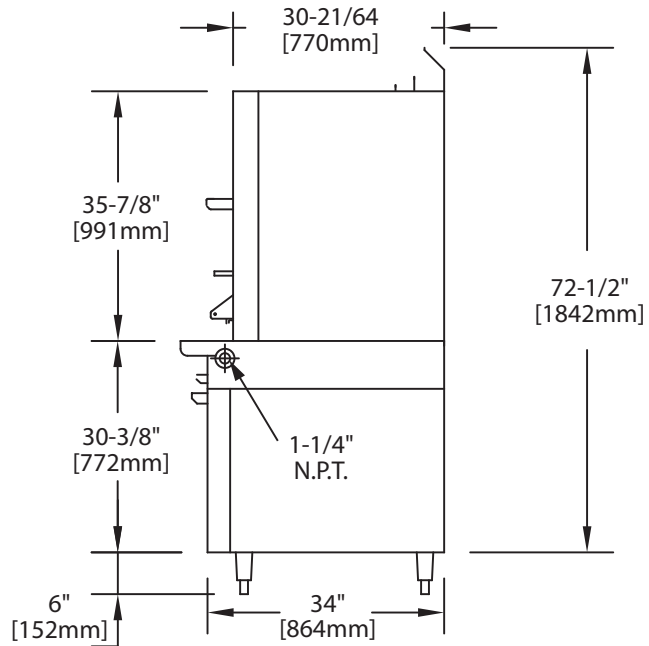
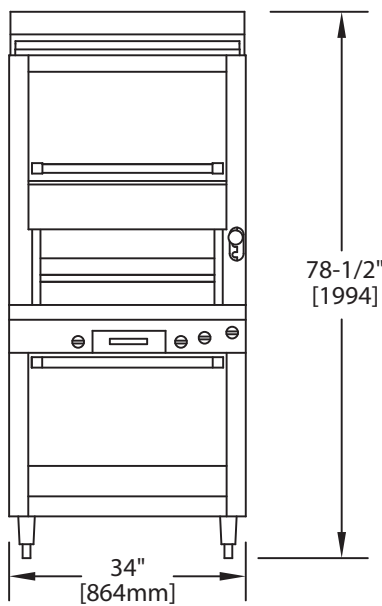

Form# M60X (08/09/10)