



# Heavy Duty Gas Griddles

Item: \_\_\_\_\_  
 Quantity: \_\_\_\_\_  
 Project: \_\_\_\_\_  
 Approval: \_\_\_\_\_  
 Date: \_\_\_\_\_

Heavy Duty Gas Griddles

### Models:

- GTGG24-GT24     GTGG36-GT36     GTGG48-GT48     GTGG60-GT60     GTGG72-GT72  
 GTGG24-G24     GTGG36-G36     GTGG48-G48     GTGG60-G60     GTGG72-G72



Model GTGG36-GT36  
(shown with optional chrome griddle plate)

### Standard Features:

- Thermostat-control models feature precise control from LOW: 175°F, (79°C) to 525°F, (274°C), full flame safety, and 32,000 BTU/h input per burner, natural or propane
- Valve-control models feature hi-lo valve control with approximate plate temperature range: 320°F, (160°C) to 730°F, (388°C), and 26,000 BTU/h input per burner, natural or propane gas.
- One burner and control (hi-lo or thermostat control) for every 12" linear width of griddle surface.
- Piezo pilot ignition system
- 3/4" NPT gas regulator with "T" gas manifold connection for straight through rear or flush-mount gas connections.
- SS front, sides and back
- 4" SS adjustable legs
- SS front rail; 4" (102mm) deep overall with 3 1/2" (89mm) top

work surface

- Large capacity SS grease tray(s)
- 1" thick polished steel griddle plate
- 23" depth with 4" wide grease trough.

### Optional Features:

- Chrome griddle plate
- Full or half-grooved griddle plate
- Stainless steel skirt for dias/ counter surface mounting
- Electric spark ignition; 120V 60 Hz, sgl-phase 1 amp; includes cord and NEMA 5-15P plug
- Stainless stand with solid top and holding shelves, and adjustable feet
- Stainless stand with solid top and holding shelves, and casters, (locking front)
- Removable stainless steel attachment condiment rail with 1/9 food pan cut outs (pans supplied by others)

Garland heavy duty gas counter production griddles designed for side-by-side matching with other models in the product line. Models are of nominal imperial widths from 24" (600mm) to 72"(1800mm), 13" (330mm) height, (w/std. legs), and 32" (814mm) depth. There is a heavy "H" shaped, cast iron even-heating burner for every 12" of linear griddle surface width. Each burner is individually controlled with a hi-lo valve or thermostat temperature control. Burner input is 26,000 BTU/h each on valve-controlled models, and 32,000 BTU/h each on thermostat controlled models. Thermostat control models are equipped with full flame safety systems. Griddle plate is standard 1" thick polished steel with a 4" wide grease trough. Stainless steel front, sides and back with large capacity stainless steel grease tray(s).



Garland  
 1333 East 179th Street  
 Cleveland, Ohio 44110  
 Phone: 800-424-2411  
 Fax: 800-624-0218

Garland Commercial Ranges Ltd  
 1177 Kamato Road,  
 Mississauga, Ontario  
 L4W 1X4 CANADA  
 Phone: 905-624-0260  
 Fax: 905-624-5669





# Heavy Duty Gas Griddles

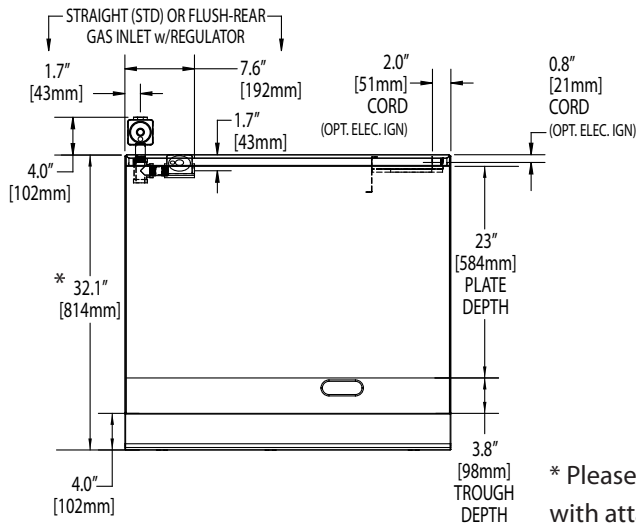

For use with Natural or Propane gas only. Gas input ratings shown for installations up to 2000 ft., (610m), above sea level. Please specify altitudes over 2000 ft. and gas type required when ordering.

Garland/U.S. Range products are not approved or authorized for home or residential use, but are intended for commercial applications only. Garland / U.S. Range will not provide service, warranty, maintenance or support of any kind other than in commercial applications.

\* Please add 5" (127mm) in overall depth with attachment condiment rail option.

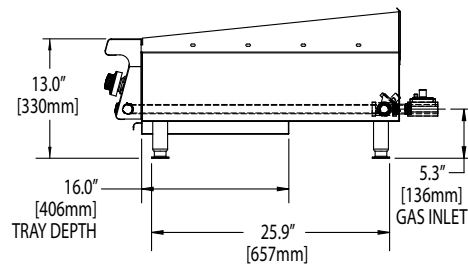
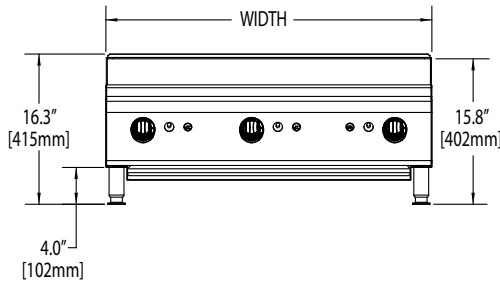

Model #	Width In (mm)	Height (w/std legs)	Depth In (mm)	Total Input (BTU)	Shipping Information	
					Lbs/Kg	Cu Ft
<b>Thermostat Controlled Standard Griddle (1" steel plate)</b>						
GTGG24-GT24	23-5/8 (600)	13 (330)	32 (814)	64,000	270/122	18
GTGG36-GT36	35-7/16 (900)			96,000	370/168	22
GTGG48-GT48	47-1/4 (1200)			128,000	441/200	33
GTGG60-GT60	59-1/16 (1500)			160,000	578/262	40
GTGG72-GT72	70-7/8 (1800)			192,000	800/363	47
<b>Manually Controlled Standard Griddle (1" steel plate)</b>						
GTGG24-G24	23-5/8 (600)	13 (330)	32 (814)	52,000	247/112	18
GTGG36-G36	35-7/16 (900)			78,000	359/159	22
GTGG48-G48	47-1/4 (1200)			104,000	446/202	33
GTGG60-G60	59-1/16 (1500)			130,000	561/254	40
GTGG72-G72	70-7/8 (1800)			156,000	690/309	47

SUPPLY OPERATING PRESSURE				MANIFOLD OPERATING PRESSURE				CLEARANCES	
NATURAL GAS		PROPANE		NATURAL GAS		PROPANE		INSTALLATION TO COMBUSTIBLE	
"WC	MBar	"WC	Mbar	"WC	MBar	"WC	Mbar	Sides	Rear
7	17.5	11	27.5	4.5	11	10	24.5	6" (152mm)	6" (152mm)

Form# GTGG (03/15/11)

Garland  
1333 East 179th Street  
Cleveland, Ohio 44110  
Phone: 800-424-2411  
Fax: 800-624-0218

Garland Commercial Ranges Ltd  
1177 Kamato Road,  
Mississauga, Ontario  
L4W 1X4 CANADA  
Phone: 905-624-0260  
Fax: 905-624-5669

