



Item: _____

Quantity: _____

Project: _____

Approval: _____

Date: _____

Heavy Duty Gas Hot Plates

Heavy Duty Gas Hot Plates

Models:

GTOG12-2

GTOG24-4

GTOG36-6

GTOG48-8



Model GTOG24-4

Standard Features:

- SS front, sides and back
- 4" SS adjustable legs
- 3/4" NPT gas regulator with "T" gas manifold connection for straight through rear or flush-mount gas connections.
- SS front rail; 4" (102mm) deep overall with 3 1/2" (89mm) top work surface
- SS large capacity crumb tray
- Split ergonomic grates which are easy to handle and clean
- Pilots are protected from spills
- 30,000 BTU (Natural Gas) Starfire Pro 2-piece star shaped gas burners
- Burners are controlled with individual adjustable valve
- Models are available with 2, 4, 6, and 8 open-top burners

Optional Features:

- Stainless steel skirt for dias/ counter surface mounting.
- Stainless stand with solid top and holding shelves, and adjustable feet
- Stainless stand with solid top and holding shelves, and casters, (locking front)
- Removable stainless steel attachment condiment rail with 1/9 food pan cut outs (pans supplied by others)

Garland designed these heavy duty counter hot plates for high-volume production, while offering the flexibility to match up with a full counter lineup. Models available with 2, 4, 6 and 8 open top burner combinations.

Available in nominal imperial widths 12" (300mm) to 48"(1200mm) with 13" (330mm) height, and 32" (814mm) depth. Split ergonomic cast iron grates protect pilots from spill-overs, and are easy to handle and clean. Each individually valve-controlled burner is rated at 30,000 BTU/h (8.78 kW) natural gas or 26,000 BTU/h (7.61 kW) propane gas. Stainless steel front, sides and back with large capacity stainless steel crumb tray.



Garland
1333 East 179th Street
Cleveland, Ohio 44110
Phone: 800-424-2411
Fax: 800-624-0218

Garland Commercial Ranges Ltd
1177 Kamato Road,
Mississauga, Ontario
L4W 1X4 CANADA
Phone: 905-624-0260
Fax: 905-624-5669





Heavy Duty Gas Hot Plates

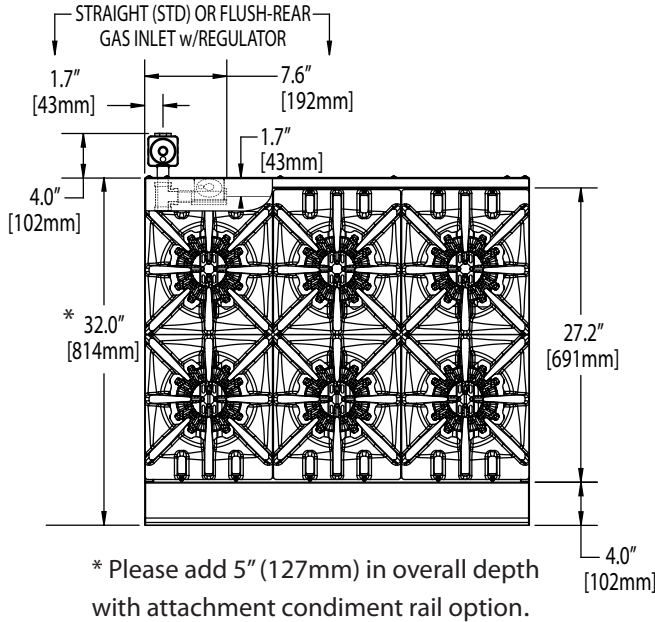

For use with Natural or Propane gas only. Gas input ratings shown for installations up to 2000 ft., (610m), above sea level. Please specify altitudes over 2000 ft. and gas type when ordering. Garland/U.S. Range products are not approved or authorized for home or residential use, but are intended for commercial applications only. Garland/U.S. Range will not provide service, warranty, maintenance or support of any kind other than in commercial applications.

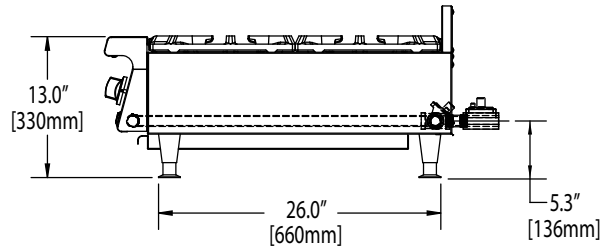
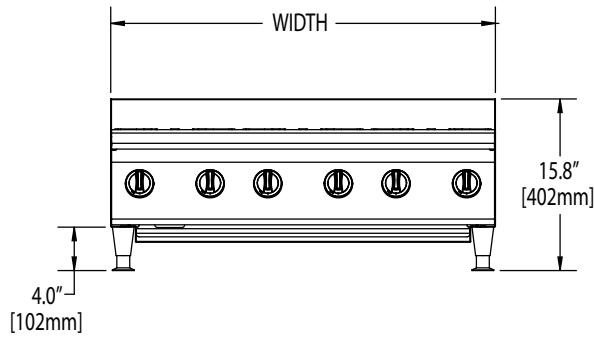

| Model # | Width In (mm) | Height (w/std legs) | Depth In (mm) | Total Input (BTU) | | Shipping Information | |
|----------|----------------|---------------------|---------------|-------------------|---------|----------------------|-------|
| | | | | NAT | PRO | Lbs/Kg | Cu Ft |
| GTOG12-2 | 11-13/16 (300) | 13 (330) | 32 (814) | 60,000 | 52,000 | 73/33 | 4 |
| GTOG24-4 | 23-5/8 (600) | | | 120,000 | 104,000 | 135/61 | 8 |
| GTOG36-6 | 35-7/16 (900) | | | 180,000 | 156,000 | 191/87 | 25 |
| GTOG48-8 | 47-1/4 (1200) | | | 240,000 | 208,000 | 247/112 | 33 |

| SUPPLY OPERATING PRESSURE | | | | MANIFOLD OPERATING PRESSURE | | | | CLEARANCES | |
|---------------------------|------|---------|------|-----------------------------|------|---------|------|-----------------------------|------------|
| NATURAL GAS | | PROPANE | | NATURAL GAS | | PROPANE | | INSTALLATION TO COMBUSTIBLE | |
| "WC | MBar | "WC | Mbar | "WC | MBar | "WC | Mbar | Sides | Rear |
| 7 | 17.5 | 11 | 27.5 | 4.5 | 11 | 10 | 24.5 | 7" (178mm) | 6" (152mm) |

Form# GTOG (03/15/11)

Garland
1333 East 179th Street
Cleveland, Ohio 44110
Phone: 800-424-2411
Fax: 800-624-0218

Garland Commercial Ranges Ltd
1177 Kamato Road,
Mississauga, Ontario
L4W 1X4 CANADA
Phone: 905-624-0260
Fax: 905-624-5669

