

BACK BAR COOLERS

EBB – Series • EBB23 • EBB48 • EBB59 • EBB69 • EBB90



▲ EBB23



▲ EBB48



▲ EBB59



▲ EBB69



▲ EBB90

Cabinet Construction

Heavy duty stainless steel countertop, with textured and laminated black vinyl exterior. Galvanized steel interior wall, and high quality stainless steel floor. 1 3/4" thick high density foamed-in-place polyurethane insulation. Pre-installed four 4" diameter casters for single door unit. Built-in caster thread receptacles for all units.

Refrigeration System

- Back mounted condensing unit for single door, and side mounted condensing unit for two and three door models
- Oversized condenser and evaporator coils quickly achieve and maintain desired temperature
- Forced-air cooling with oversized evaporator fan motors provide balanced airflow throughout cabinet to ensure faster temperature drop
- Removable side panel and slide-out condensing unit for convenient repair and maintenance
- Environmentally friendly CFC free R-134A refrigerant
- Air defrost controlled by electrical timer
- Copper tube and aluminum fin evaporator with anti-corrosive coating
- Energy efficient condensate drain pan assembly heated by high side copper tube
- Pre-wired and ready to plug, 115V/60Hz/1Ph, NEMA 5-15P

Lighting

- Shielded vertical LED interior lighting with on/off switch for energy efficiency, minimal heat generation and enhanced illumination (not applicable to EBB23 models manufactured prior to 2017)

Doors

- Textured and laminated black exterior with galvanized steel interior
- 1 3/4" thick high density foamed-in-place polyurethane insulation
- One piece snap-in magnetic door gaskets for easy replacement
- Heavy duty recessed door handles for a flat surface
- Door locks

Shelving

- Two epoxy coated wire shelves per section
- Stainless steel pilasters and shelf clips

Temperature Control

- Factory preset temperature, 35°F
- Temperature setting range from 32°F to 42°F
- Easy to set analog thermostat

Option

- 2 1/2" and 4" diameter casters (3 1/2" and 5" overall height) optional for all models except EBB23



Dimensions

Side View (all models except EBB23)

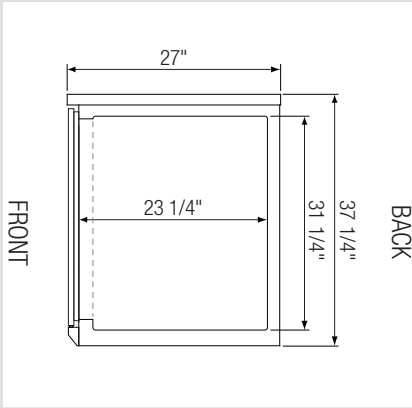

Equipped with 9 ft long NEMA 5-15P plug.

Side View (EBB23)

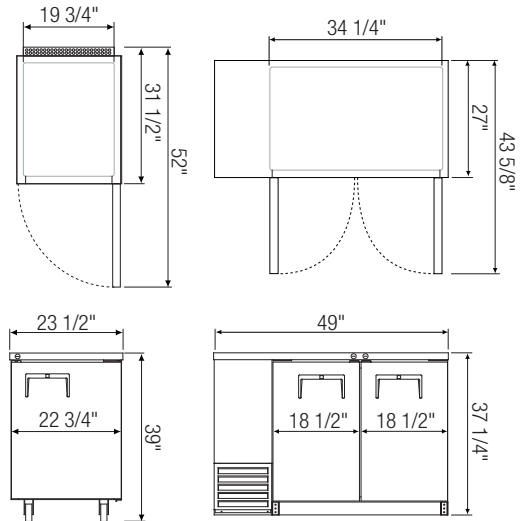
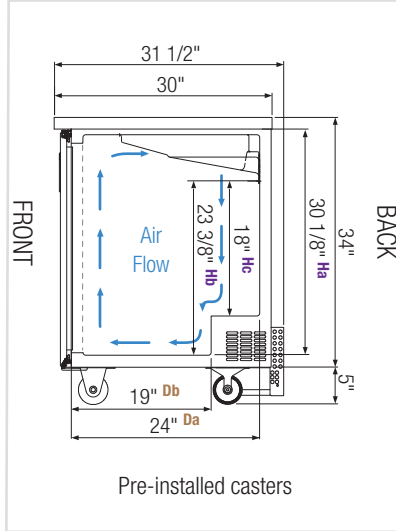

▲ EBB23

▲ EBB48

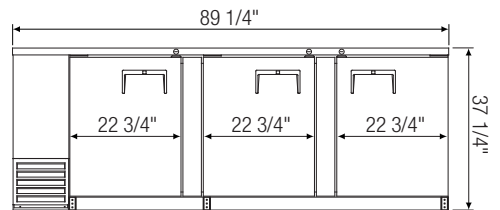
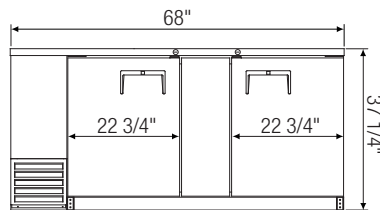
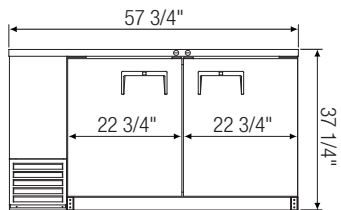
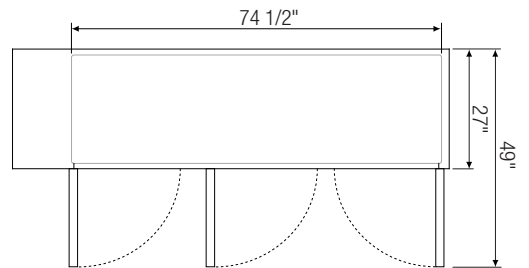
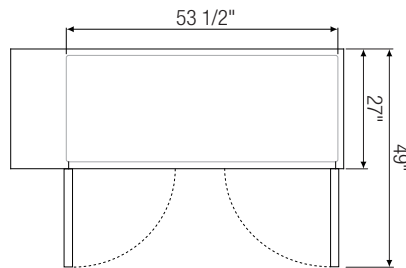
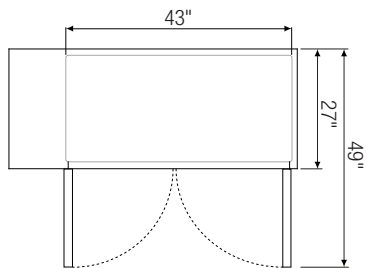

▲ EBB59

▲ EBB69

▲ EBB90

Model	Ref/ Frz/ Dual	# of Doors	# of Shelves	Capacity (Cu.Ft.)	HP	Refrigerant	Capacity		Power (V-Hz-Ph)	Amps	Crated Weight (LBS)	Exterior Dimensions (Inches)			Interior Dimensions (Inches)		
							12 oz. Cans	12 oz. Bottles				L	D	H	L	D	H
EBB23	Ref	1	2	8.19	1/5	R-134A	220	125	115-60-1	3.90	158	23 1/2	31 1/2 [†]	39 [*]	19 3/4	24 ^{Da} 19 ^{Db}	30 1/8 ^{Ha} 23 3/8 ^{Hb} 18 ^{Hc}
EBB48	Ref	2	4	14.3	1/4+	R-134A	490	344	115-60-1	4.20	260	49	27	37 1/4	34 1/4	23 1/4	31 1/4
EBB59	Ref	2	4	20.09	1/4+	R-134A	640	408	115-60-1	4.50	297	57 3/4	27	37 1/4	43	23 1/4	31 1/4
EBB69	Ref	2	4	24.01	1/4+	R-134A	800	504	115-60-1	4.50	329	68	27	37 1/4	53 1/2	23 1/4	31 1/4
EBB90	Ref	3	6	32.37	1/3	R-134A	1120	696	115-60-1	4.50	420	89 1/4	27	37 1/4	74 1/2	23 1/4	31 1/4

* : Height includes 5" for casters.

† : Depth includes 1 1/2" for back grill.

Da, Db : Interior Depth Ha, Hb, Hc : Interior Height

Ref = Refrigerator

Specifications subject to change without notice.

Product dimensions are for general purposes and not absolute value. Product capacity(▶) is calculated based on standard industry figures. Slight variations may exist. If dimensions and capacity are critical, please contact Everest Refrigeration.



Please visit our website for updated Energy Efficiency information.