

24" DEEP BACK BAR COOLERS

EBB – Series • EBB48-24 • EBB59-24 • EBB69-24 • EBB90-24



▲ EBB48-24



▲ EBB59-24



▲ EBB69-24



▲ EBB90-24

Cabinet Construction

Heavy duty stainless steel countertop, with textured and laminated black vinyl exterior. Galvanized steel interior wall, and high quality stainless steel floor. 1 3/4" thick high density foamed-in-place polyurethane insulation. Built-in caster thread receptacles for all units.

Refrigeration System

- Side mounted condensing unit
- Oversized condenser and evaporator coils quickly achieve and maintain desired temperature
- Forced-air cooling with oversized evaporator fan motors provide balanced airflow throughout cabinet to ensure faster temperature drop
- Removable side panel and slide-out condensing unit for convenient repair and maintenance
- Environmentally friendly CFC free R-134A refrigerant
- Air defrost controlled by electrical timer
- Copper tube and aluminum fin evaporator with anti-corrosive coating
- Energy efficient condensate drain pan assembly heated by high side copper tube
- Pre-wired and ready to plug, 115V/60Hz/1Ph, NEMA 5-15P

Lighting

- Shielded vertical LED interior lighting with on/off switch for energy efficiency, minimal heat generation and enhanced illumination

Doors

- Textured and laminated black exterior with galvanized steel interior
- 1 3/4" thick high density foamed-in-place polyurethane insulation
- One piece snap-in magnetic door gaskets for easy replacement
- Heavy duty recessed door handles for a flat surface
- Door locks

Shelving

- Two epoxy coated wire shelves per section
- Stainless steel pilasters and shelf clips

Temperature Control

- Factory preset temperature, 35°F
- Temperature setting range from 32°F to 42°F
- Easy to set analog thermostat

Option

- 2 1/2" and 4" diameter casters (3 1/2" and 5" overall height)



Dimensions

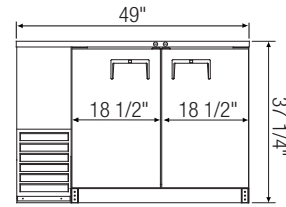
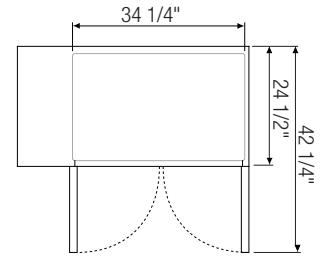
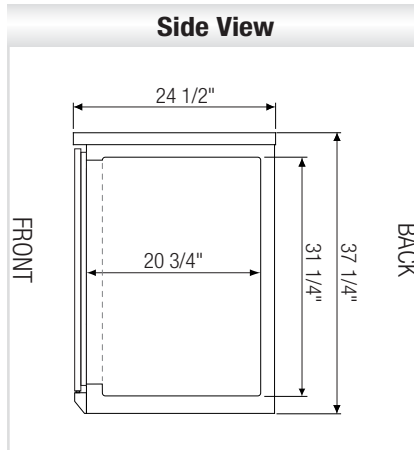
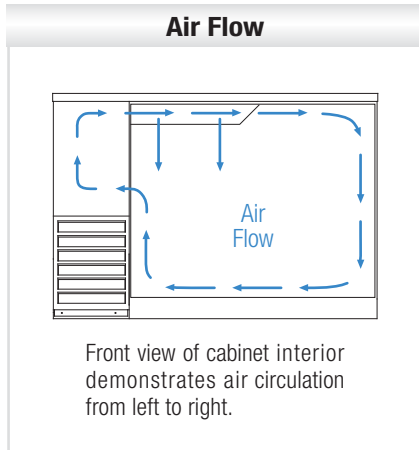

Equipped with 9 ft long NEMA 5-15P plug.

▲ **EBB48-24**

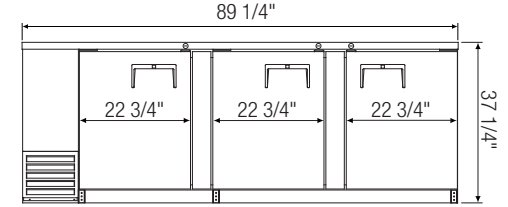
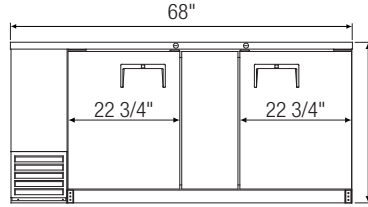
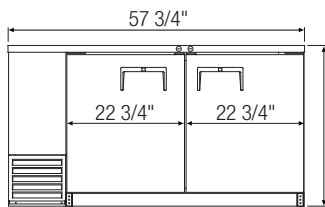
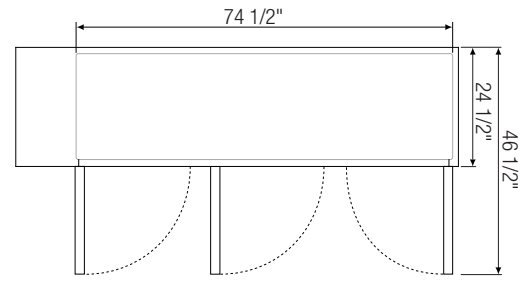
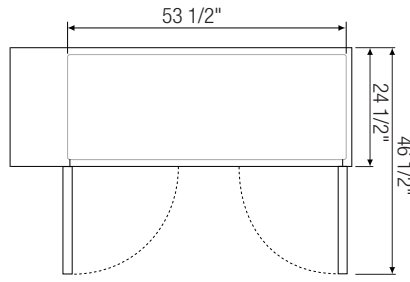
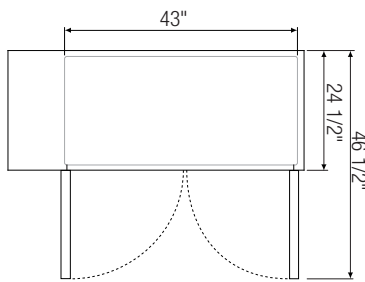

▲ **EBB59-24**

▲ **EBB69-24**

▲ **EBB90-24**

Model	Ref/ Frz/ Dual	# of Doors	# of Shelves	Capacity [†] (Cu.Ft.)	HP	Refrigerant	Capacity		Power (V-Hz-Ph)	Amps	Crated Weight (LBS)	Exterior Dimensions (Inches)			Interior Dimensions (Inches)		
							12 oz. Cans	12 oz. Bottles				L	D	H	L	D	H
EBB48-24	Ref	2	4	13.95	1/4+	R-134A	420	294	115-60-1	4.50	253	49	24 1/2	37 1/4	34 1/4	20 3/4	31 1/4
EBB59-24	Ref	2	4	16.86	1/4+	R-134A	560	357	115-60-1	4.50	280	57 3/4	24 1/2	37 1/4	43	20 3/4	31 1/4
EBB69-24	Ref	2	4	20.41	1/4+	R-134A	700	441	115-60-1	4.50	307	68	24 1/2	37 1/4	53 1/2	20 3/4	31 1/4
EBB90-24	Ref	3	6	27.76	1/3	R-134A	980	609	115-60-1	4.50	381	89 1/4	24 1/2	37 1/4	74 1/2	20 3/4	31 1/4

Ref = Refrigerator

Specifications subject to change without notice.

Product dimensions are for general purposes and not absolute value. Product capacity(†) is calculated based on standard industry figures. Slight variations may exist. If dimensions and capacity are critical, please contact Everest Refrigeration.



Please visit our website for updated Energy Efficiency information.