

CHEF BASES (Two Drawer) Side Mounted Condensing Unit

ECB – Series • ECB36D2 • ECB48D2 • ECB52D2 • ECB52-60D2



▲ ECB36D2



▲ ECB48D2



▲ ECB52D2



▲ ECB52-60D2

Cabinet Construction

Heavy duty stainless steel interior and exterior, with galvanized steel finished bottom and back wall of exterior. High quality 16 gauge stainless steel worktop. 2.5" thick high density foamed-in-place polyurethane insulation. Four 4" diameter casters (front casters with brakes) with additional front weight support legs. 12 gauge sheet metal caster brackets installed at bottom of cabinet to support added weight of mounted cooking equipment. Air chamber and vents preserve the structural integrity of the worktop. High heat insulation material able to withstand extreme heat of up to 500°F is layered between the worktop panel and unit body to ensure cold cabinet temperature, preserve freshness of food and reduce energy costs. Durable stainless steel corner guards mounted on the top surface prevent cooking equipment from accidentally sliding off the unit. Heavy duty stainless steel top surface grips for easy and safe maneuverability of the unit.

Recommended Operating Conditions

Minimum clearance of 4" is required between bottom of cooking equipment heating element and chef base worktop. Failure to provide clearance voids manufacturer warranty.

Temperature Control

- Factory preset temperature, 35°F
- Temperature setting range from 33°F to 54°F
- Easy to read digital temperature display
- Easy to program push-button temperature control
- Microchip digital control and monitoring system with a variety of functions to monitor and maintain optimum temperature

Refrigeration System

- Side mounted condensing unit for large compartment use for drawers
- Oversized condenser and evaporator coils quickly achieve and maintain desired temperature
- Forced-air cooling with multiple evaporator fan motors provide balanced airflow throughout cabinet to ensure faster temperature drop
- Removable side panel and slide-out condensing unit for convenient repair and maintenance
- Removable condenser coil air filter for easy cleaning
- Environmentally friendly CFC free R-134A refrigerant
- Air defrost, time-initiated and terminated
- Copper tube and aluminum fin evaporator with anti-corrosive coating
- Energy efficient condensate drain pan assembly heated by high side copper tube
- Pressure relief ports for rapid re-entry
- Pre-wired and ready to plug, 115V/60Hz/1Ph, NEMA 5-15P

Drawers

- Heavy duty stainless steel interior and exterior
- Heavy duty 304 stainless steel drawer frames with low-friction ball bearing slides
- 2" thick foamed-in-place polyurethane insulation
- One piece snap-in heat resistant drawer gaskets for easy replacement
- Heavy duty recessed drawer handles for a flat surface
- Sanitary polycarbonate 1(full) size & 1/6 size pans
(note: refer to website for pan configurations)



Dimensions

Side View

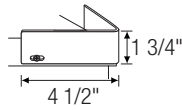

Corner Guards

Durable stainless steel corner guards mounted on the top surface prevent cooking equipment from accidentally sliding off the unit.

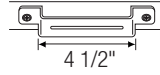

Stainless Steel Grips

Heavy duty stainless steel top surface grips for easy and safe maneuverability of the unit.

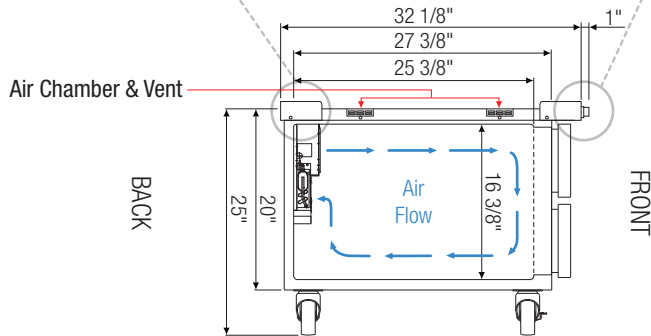

ABS Legs

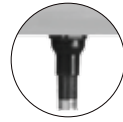

Two additional front adjustable stainless steel clad ABS legs to provide extra stability when opening, closing doors and weight support.



Equipped with 9 ft long NEMA 5-15P plug.

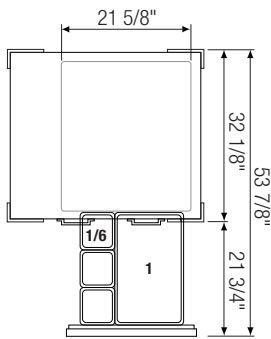

▲ ECB36D2

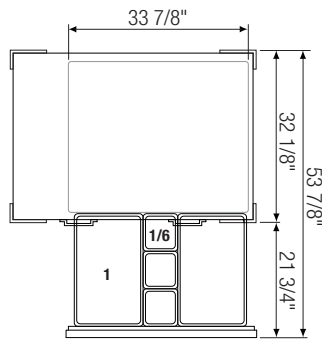

▲ ECB48D2

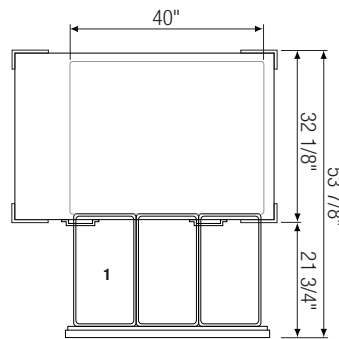

▲ ECB52D2

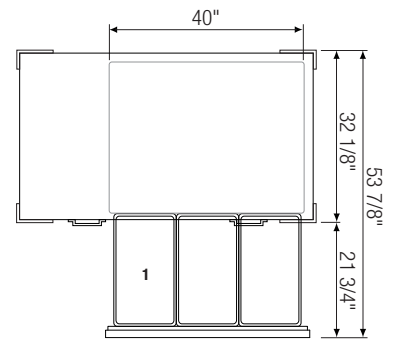

▲ ECB52-60D2

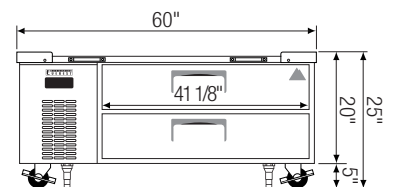
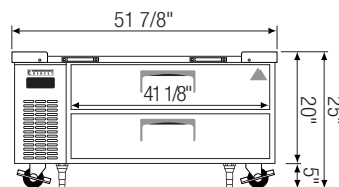
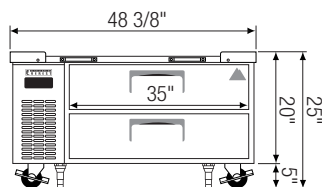
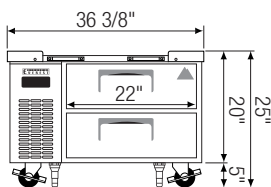

Model	Ref/ Frz/ Dual	# of Drawers	Max. Weight Support Capacity (LBS)	HP	Refrigerant	# of Pans	BTU/HR [†]	Power (V-Hz-Ph)	Amps	Crated Weight (LBS)	Exterior Dimensions (Inches) ^a *			Interior Dimensions (Inches)		
											L	D	H	L	D	H
ECB36D2	Ref	2	717	1/5	R-134A	1 x 2 1/6 x 6	1,974	115-60-1	4.20	242	36 3/8	32 1/8	20	21 5/8	27 3/8	16 3/8
ECB48D2	Ref	2	717	1/4+	R-134A	1 x 4 1/6 x 6	2,075	115-60-1	4.40	300	48 3/8	32 1/8	20	33 7/8	27 3/8	16 3/8
ECB52D2	Ref	2	717	1/4+	R-134A	1 x 6	2,075	115-60-1	4.40	315	51 7/8	32 1/8	20	40	27 3/8	16 3/8
ECB52-60D2	Ref	2	717	1/4+	R-134A	1 x 6	2,075	115-60-1	4.40	337	60	32 1/8	20	40	27 3/8	16 3/8

* : Height does not include 5" for casters.

† : Based on evaporating temperature of 23°F (-5°C) & condensing temperature of 131°F (55°C).

a : Depth does not include 1" for stainless steel grip.

Ref = Refrigerator

Specifications subject to change without notice.

Product dimensions are for general purposes and not absolute value. Product capacity(▶) is calculated based on standard industry figures. Slight variations may exist. If dimensions and capacity are critical, please contact Everest Refrigeration.



Please visit our website for updated Energy Efficiency information.