

BACK BAR & DIRECT DRAW KEG REFRIGERATORS

EBD – Series • EBD2-BB • EBD2-BBG • EBD3-BB • EBD3-BBG



▲ EBD2-BB



▲ EBD2-BBG



▲ EBD3-BB



▲ EBD3-BBG

Cabinet Construction

Heavy duty stainless steel countertop, textured and laminated black vinyl exterior. Galvanized steel interior wall and high quality stainless steel floor. 1 3/4" thick high density foamed-in-place polyurethane insulation. Built-in caster thread receptacles for all units.

Refrigeration System

- Side mounted condensing unit
- Oversized condenser and evaporator coils quickly achieve and maintain desired temperature
- Forced-air cooling with oversized evaporator fan motors provide balanced airflow throughout cabinet to ensure faster temperature drop
- Removable side panel and slide-out condensing unit for convenient repair and maintenance
- Environmentally friendly CFC free R-134A refrigerant
- Air defrost controlled by electrical timer
- Copper tube and aluminum fin evaporator with anti-corrosive coating
- Energy efficient condensate drain pan assembly heated by high side copper tube
- Pre-wired and ready to plug, 115V/60Hz/1Ph, NEMA 5-15P

Lighting

- Shielded vertical LED interior lighting with on/off switch for energy efficiency, minimal heat generation and enhanced illumination

Doors

- Textured and laminated black exterior with galvanized steel interior for solid doors, and black PVC frames with low emissivity double pane glass system for glass doors
- 1 3/4" thick high density foamed-in-place polyurethane insulation
- One piece snap-in magnetic door gaskets for easy replacement
- Heavy duty recessed and die-cast door handles
- Door locks

Draft Arms

- NSF approved 3" diameter insulated stainless steel draft arm with air distributor

Shelving

- Two epoxy coated wire shelves
- Stainless steel pilasters and shelf clips

Temperature Control

- Factory preset temperature, 35°F
- Temperature setting range from 32°F to 42°F
- Easy to set analog thermostat

Options

- 2 1/2" and 4" diameter casters (3 1/2" and 5" overall height)
- Dual faucet towers



5 YEAR Compressor
3 YEAR Parts & Labor

Dimensions

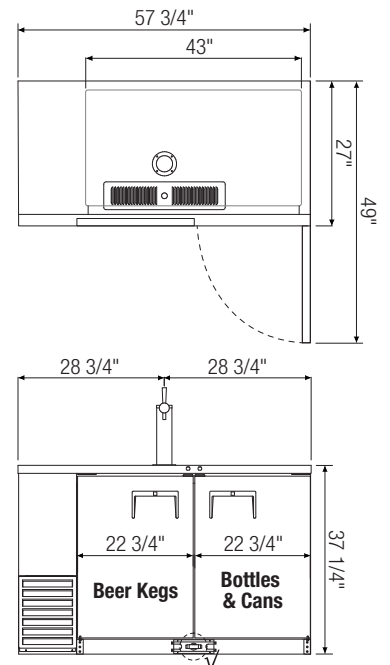
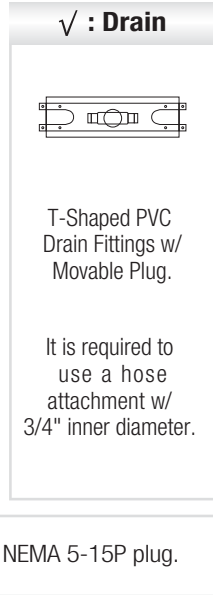
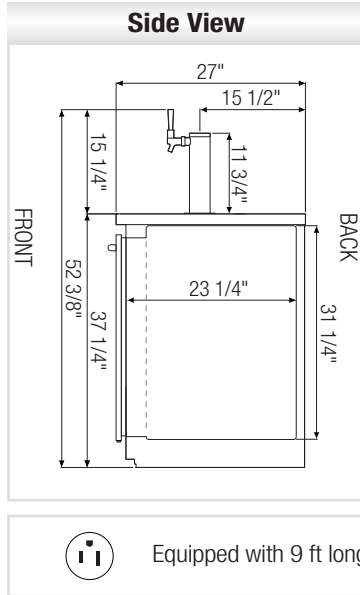
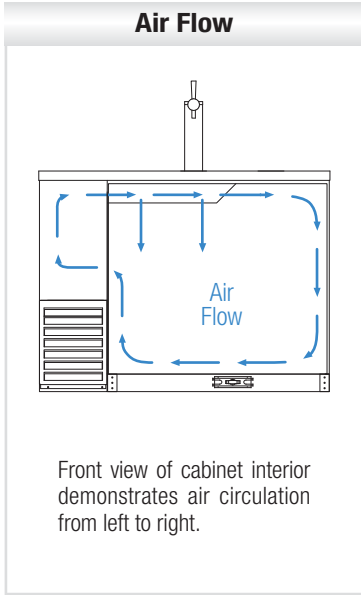

▲ EBD2-BB

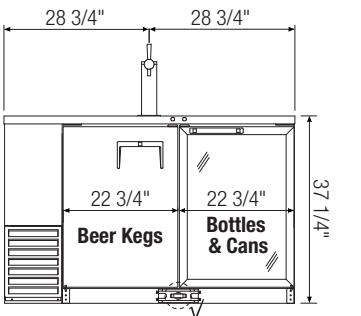
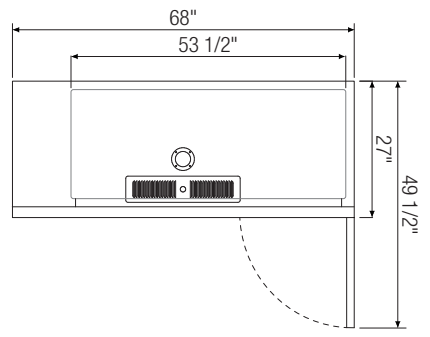
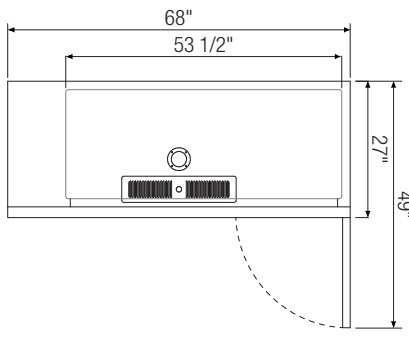
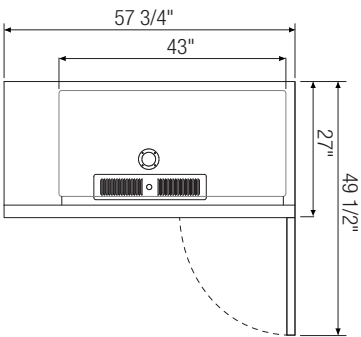

▲ EBD2-BBG

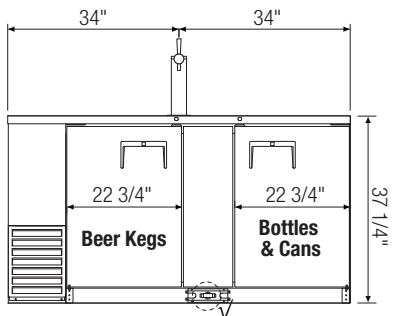

▲ EBD3-BB

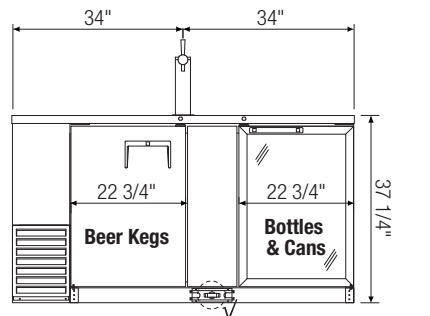

▲ EBD3-BBG

Model	Ref/ Frz/ Dual	# of Doors	Capacity & Size of Barrels	HP	Refrigerant	# of Shelves	Capacity		Power (V-Hz-Ph)	Amps	Crated Weight (LBS)	Exterior Dimensions (Inches)			Interior Dimensions (Inches)		
							12 oz. Cans	12 oz. Bottles				L	D	H	L	D	H
EBD2-BB	Ref	2 (SD)	(1) 1/2	1/4+	R-134A	2	280	192	115-60-1	4.50	280	57 3/4	27	37 1/4	43	23 1/4	31 1/4
EBD2-BBG	Ref	1 (SD) 1 (GD)	(1) 1/2	1/4+	R-134A	2	280	192	115-60-1	4.50	297	57 3/4	27	37 1/4	43	23 1/4	31 1/4
EBD3-BB	Ref	2 (SD)	(1) 1/2 (1) 1/4-Slim	1/4+	R-134A	2	360	240	115-60-1	4.50	320	68	27	37 1/4	53 1/2	23 1/4	31 1/4
EBD3-BBG	Ref	1 (SD) 1 (GD)	(1) 1/2 (1) 1/4-Slim	1/4+	R-134A	2	360	240	115-60-1	4.50	337	68	27	37 1/4	53 1/2	23 1/4	31 1/4

Ref = Refrigerator | (SD) = Solid Door | (GD) = Glass Door

Specifications subject to change without notice.

Product dimensions are for general purposes and not absolute value. Product capacity(▶) is calculated based on standard industry figures. Slight variations may exist. If dimensions and capacity are critical, please contact Everest Refrigeration.



Please visit our website for updated Energy Efficiency information.