

# GLASS DOOR MERCHANDISER FREEZERS

## Swing Doors

EM – Series • EMGF23 • EMGF36 • EMGF48 • EMGF69



### Cabinet Construction

Heavy duty white coated steel for cabinet interior and exterior. High quality stainless steel interior floor with round edges for convenient cleaning. 2.5" thick high density foamed-in-place polyurethane insulation. Four or six 4" diameter casters (front casters with brakes) with additional front weight support legs. Door heater installed around inside cabinet frame to prevent moisture build-up.

### Refrigeration System

- Bottom mounted condensing unit
- Removable bottom grill and slide-out condensing unit for easy repair and maintenance
- Oversized condenser and evaporator coils quickly achieve and maintain desired temperature
- Removable condenser coil air filter for easy cleaning
- Forced-air cooling with oversized evaporator fan motors provide balanced airflow throughout cabinet to ensure faster temperature drop
- Environmentally friendly CFC free R-404A refrigerant
- Hot gas defrost cycle (time-initiated and temperature terminated)
- Copper tube and aluminum fin evaporator with anti-corrosive coating
- Pressure relief ports for rapid re-entry
- Interior airflow backward to ensure proper air circulation
- Energy efficient condensate drain pan utilizing hot gas pipe
- Pre-wired and ready to plug, 115V/60Hz/1Ph, NEMA 5-20P (EMGF23)
- Pre-wired power cord without plug, 230V/60Hz/1Ph (EMGF36 / EMGF48 / EMGF69)

### Doors

- Matte finish aluminum door frames
- Low emissivity triple pane glass system reflects UV rays and improves insulation for maximized energy efficiency
- Defroster strips on glass door to ensure product visibility
- Heavy duty adjustable torsion spring self-closing door system
- One piece snap-in magnetic door gasket for easy replacement
- Heavy duty die-cast door handles
- Door locks

### Lighting

- Shielded vertical LED interior lighting with on/off switch for energy efficiency, minimal heat generation and enhanced illumination

### Shelving

- Four epoxy coated wire shelves per section
- Stainless steel pilasters and shelf clips

### Temperature Control

- Factory preset temperature, -4°F
- Temperature setting range from -10°F to 54°F
- Easy to read digital temperature display
- Easy to program push-button temperature control
- Microchip digital control and monitoring system with a variety of functions to monitor and maintain optimum temperature



**5 YEAR** Compressor  
**3 YEAR** Parts & Labor

## Dimensions

### ABS Legs



Additional front adjustable stainless steel clad ABS legs to provide extra stability when opening and closing doors.

### ✓: Vacuum Relief Mechanism



The vacuum relief valve equalizes cabinet pressure for rapid door re-entry.



Equipped with 9 ft long NEMA 5-20P plug. (model EMGF23)

### Side View

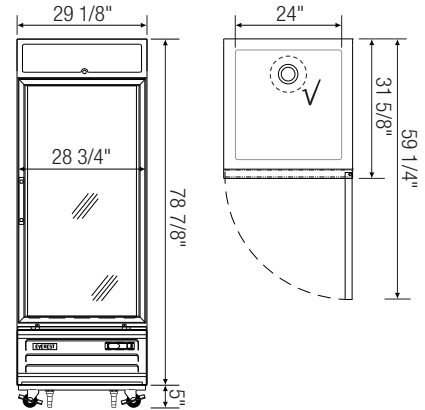
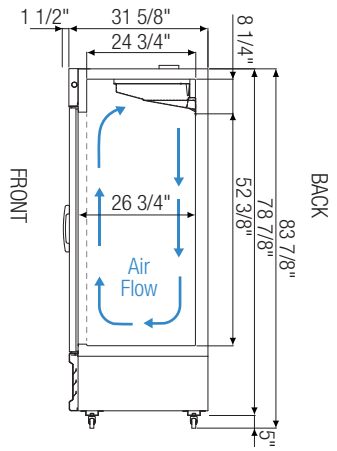

▲ EMGF23

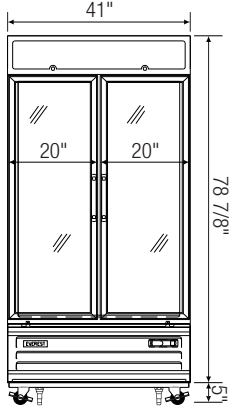
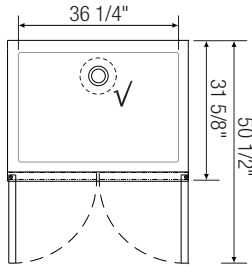

▲ EMGF36

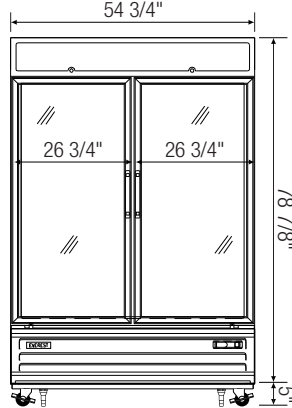
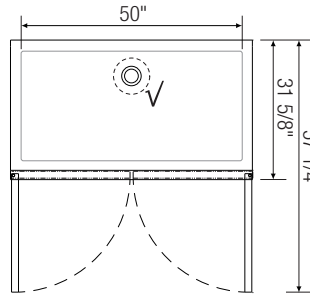

▲ EMGF48

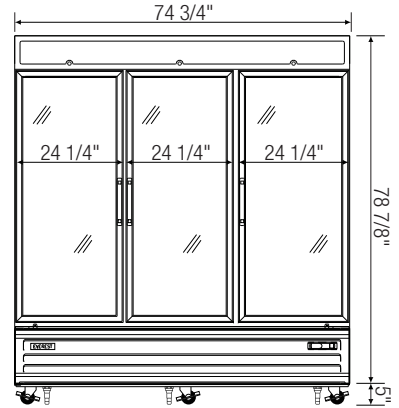
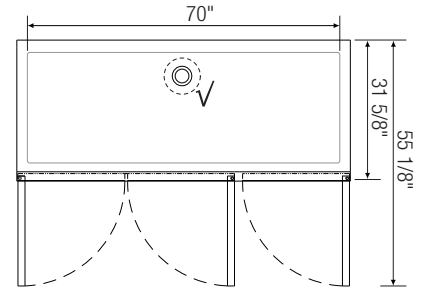

▲ EMGF69

Model	Ref/ Frz/ Dual	# of Doors	Capacity (Cu.Ft.)	HP	BTU/HR †	Refrigerant	# of Shelves	Power (V-Hz-Ph)	Amps	Crated Weight (LBS)	Exterior Dimensions (Inches)			Interior Dimensions (Inches)		
											L	D	H *	L	D	H
EMGF23	Frz	1	23	1-	4,036	R-404A	4	115-60-1	11.06	400	29 1/8	31 5/8	78 7/8	24	26 3/4	60 5/8
EMGF36	Frz	2	36	1-1/4	5,441	R-404A	8	230-60-1	5.40	532	41	31 5/8	78 7/8	36 1/4	26 3/4	60 5/8
EMGF48	Frz	2	48	1-x 2	4,036 x 2	R-404A	8	230-60-1	8.24	701	54 3/4	31 5/8	78 7/8	50	26 3/4	60 5/8
EMGF69	Frz	3	69	1-1/4 x 2	5,441 x 2	R-404A	12	230-60-1	11.20	1045	74 3/4	31 5/8	78 7/8	70	26 3/4	60 5/8

\* : Height does not include 5" for casters.

† : Based on evaporating temperature of -4°F (-20°C) & condensing temperature of 131°F (55°C).

a : Exterior depth dimension does not include 1 1/2" for door handles.

Frz = Freezer

Specifications subject to change without notice.

Product dimensions are for general purposes and not absolute value. Product capacity(▶) is calculated based on standard industry figures. Slight variations may exist. If dimensions and capacity are critical, please contact Everest Refrigeration.



Please visit our website for updated Energy Efficiency information.