

DOOR & DRAWER COMBO UPRIGHT REACH-INS

Top Mounted Condensing Unit

ES – Series • ESR1D2 • ESR2D2 • ESR2D4 • ESRF2D2 • ESWQ2D2



▲ ESR1D2



▲ ESR2D2



▲ ESR2D4



▲ ESRF2D2
(Dual Temp)



▲ ESWQ2D2
(Dual Temp)

Cabinet Construction

Heavy duty stainless steel interior and exterior, with galvanized steel finished top, bottom and back wall of exterior. ABS evaporator drain covers. 2.5" thick high density foamed-in-place polyurethane insulation. Four 4" diameter casters (front casters with brakes). Door heater installed around inside cabinet frame to prevent moisture build-up.

Refrigeration System

- Self-contained condensing unit located at top of cabinet for high performance
- Oversized condenser and evaporator coils quickly achieve and maintain desired temperature
- Forced-air cooling with multiple evaporator fan motors provide balanced airflow throughout cabinet to ensure faster temperature drop
- Environmentally friendly CFC free R-134A and R-404A refrigerant
- Adjustable, time-initiated defrost cycle of 3 to 12 hours with 350 watt defrost heater, both time and temperature terminated for fail-safe operation
- Automatic evaporator fan motor delay after defrost cycle
- Copper tube and aluminum fin evaporator with anti-corrosive coating
- Exterior anodized aluminum drain pan for self sufficient condensation removal
- Pressure relief ports for rapid re-entry
- Interior airflow back guard to ensure proper air circulation
- Pre-wired and ready to plug, 115V/60Hz/1Ph, NEMA 5-15P

Lighting

- Shielded incandescent interior lighting

Doors & Drawers

- Heavy duty stainless steel interior and exterior
- 2.5" thick high density foamed-in-place polyurethane insulation
- Rounded corners for a comfortable and hazard-free work space
- Heavy duty adjustable torsion spring self-closing door system
- One piece snap-in magnetic door and drawer gaskets for easy replacement
- Heavy duty recessed door and drawer handles for a flat surface
- Heavy duty 304 stainless steel drawer frames with low-friction ball bearing slides
- Door locks
(note: refer to the website for pan configurations)

Shelving

- Epoxy coated wire shelves *(see next page for shelf quantity)*
- Stainless steel pilasters and shelf clips

Temperature Control

- Factory preset temperature, 35°F for refrigerators and -4°F for freezers
- Temperature setting range from 33°F to 54°F for refrigerators and -10° F to 54° F for freezers
- Easy to read digital temperature display
- Easy to program push-button temperature control
- Microchip digital control and monitoring system with a variety of functions to monitor and maintain optimum temperature



Dimensions

ABS Legs



Two additional front adjustable stainless steel clad ABS legs for model ESR1D2 to provide extra stability when opening and closing doors.



Equipped with 9 ft long NEMA 5-15P plug.

Side View

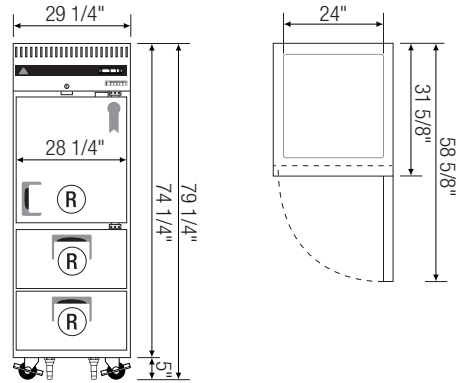
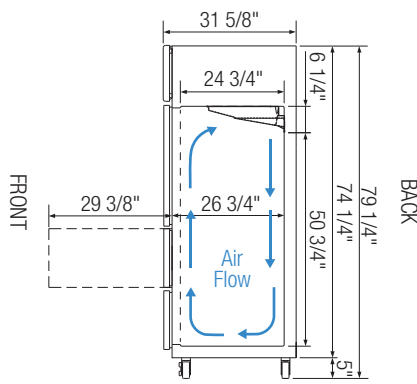

▲ ESR1D2

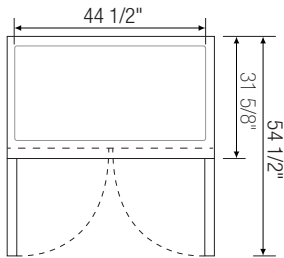

▲ ESR2D2

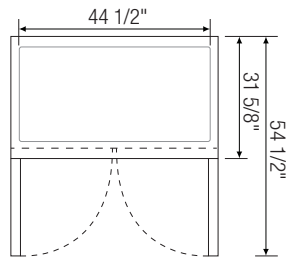

▲ ESR2D4

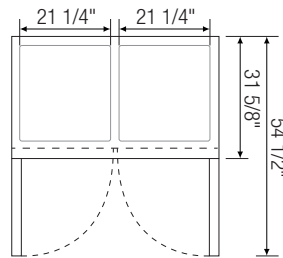

▲ ESRF2D2 (Dual Temp)

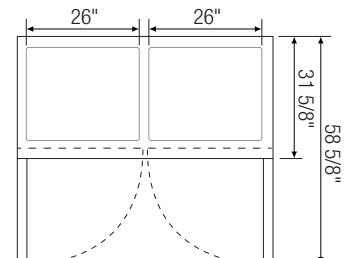

▲ ESWQ2D2 (Dual Temp)

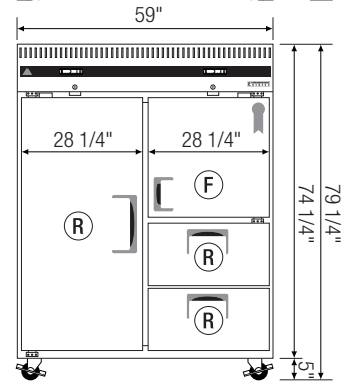
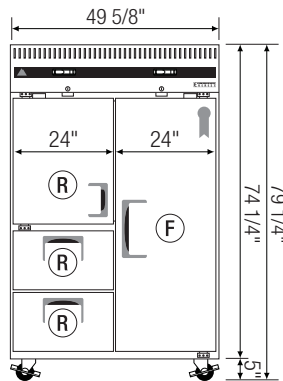
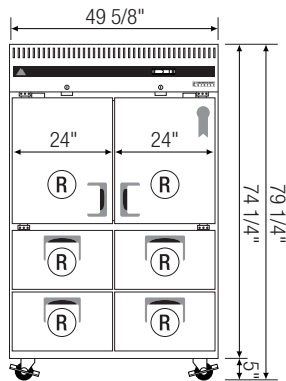
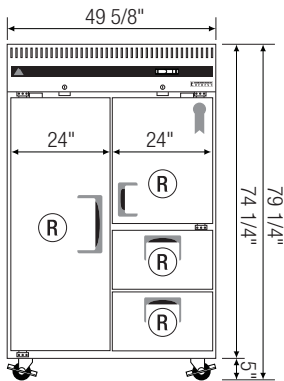

Model	Ref/ Frz/ Dual	# of Doors	Capacity (Cu.Ft.)	HP	BTU/HR †	Refrigerant	# of Shelves	Power (V-Hz-Ph)	Amps	Crated Weight (LBS)	Exterior Dimensions (Inches)			Interior Dimensions (Inches)		
											L	D	H*	L	D	H
ESR1D2	Ref	1 (H) 2 (Dr)	23	1/3	2,041	R-134A	2	115-60-1	4.92	335	29 1/4	31 5/8	74 1/4	24	26 3/4	57
ESR2D2	Ref	1 (F) / 1 (H) 2 (Dr)	48	1/3	2,041	R-134A	5	115-60-1	5.25	450	49 5/8	31 5/8	74 1/4	44 1/2	26 3/4	57
ESR2D4	Ref	2 (H) 4 (Dr)	48	1/3	2,041	R-134A	4	115-60-1	5.25	466	49 5/8	31 5/8	74 1/4	44 1/2	26 3/4	57
ESRF2D2	Dual	1 (FD) / 1 (H) 2 (Dr)	22 (R)	1/3 (R)	2,041 (R)	R-134A (R)	5	115-60-1	11.94	512	49 5/8	31 5/8	74 1/4	21 1/4	26 3/4	57 (R)
			22 (F)	1/2 (F)	3,435 (F)	R-404A (F)								21 1/4	26 3/4	57 (F)
ESWQ2D2	Dual	1 (F) / 1 (H) 2 (Dr)	39 (R)	1/3 (R)	2,041 (R)	R-134A (R)	4	115-60-1	11.94	543	59	31 5/8	74 1/4	26	26 3/4	57 (R)
			13 (F)	1/3 (F)	2,041 (F)	R-134A (F)								26	26 3/4	27 3/8 (R)
														26	26 3/4	27 3/8 (F)

* : Height does not include 5" for casters.

† : Based on evaporating temperature of 14°F (-10°C) & condensing temperature of 131°F (55°C).

Ref = Refrigerator | Dual = Ref & Frz Combo
 (H) = Half Door | (FD) = Full Door | (Dr) = Drawer

Specifications subject to change without notice.

Product dimensions are for general purposes and not absolute value. Product capacity(▶) is calculated based on standard industry figures. Slight variations may exist. If dimensions and capacity are critical, please contact Everest Refrigeration.



Please visit our website for updated Energy Efficiency information.