

GLASS & SOLID COMBINATION HALF-DOOR UPRIGHT REACH-IN REFRIGERATORS

Top Mounted Condensing Unit



ES – Series • EGS2 • EGS2H2 • EGS4 • EGSWH4 • EGS6



▲ EGS2



▲ EGS2H2
(Dual Temp)



▲ EGS4



▲ EGSWH4



▲ EGS6

Cabinet Construction

Heavy duty stainless steel interior and exterior, with galvanized steel finished top, bottom and back wall of exterior. ABS evaporator drain covers. 2.5" thick high density foamed-in-place polyurethane insulation. Four 4" diameter casters (front casters with brakes). Door heater installed around inside cabinet frame to prevent moisture build-up.

Refrigeration System

- Self-contained condensing unit located at top of cabinet for high performance
- Oversized condenser and evaporator coils quickly achieve and maintain desired temperature
- Forced-air cooling with multiple evaporator fan motors provide balanced airflow throughout cabinet to ensure faster temperature drop
- Environmentally friendly CFC free R-134A and R-404A refrigerant
- Adjustable, time-initiated defrost cycle of 3 to 12 hours with 350 watt defrost heater, both time and temperature terminated for fail-safe operation
- Automatic evaporator fan motor delay after defrost cycle
- Copper tube and aluminum fin evaporator with anti-corrosive coating
- Exterior anodized aluminum drain pan for self sufficient condensation removal
- Pressure relief ports for rapid re-entry
- Interior airflow backward to ensure proper air circulation
- Pre-wired and ready to plug, 115V/60Hz/1Ph, NEMA 5-15P

Lighting

- Shielded vertical LED interior lighting with on/off switch for energy efficiency, minimal heat generation and enhanced illumination

Doors

- Matte finish aluminum door frames
- Low emissivity double pane glass system reflects UV rays and improves insulation for maximized energy efficiency
- Heavy duty stainless steel interior and exterior
- 2.5" thick foamed-in-place polyurethane insulation
- Rounded corners for a comfortable and hazard-free work space
- Heavy duty die-cast handles for glass doors and recessed handles for solid doors
- Models available in left hinge upon request except EGS4, EGSWH4 and EGS6
- Door locks

Shelving

- Four epoxy coated wire shelves per section
- Stainless steel pilasters and shelf clips

Temperature Control

- Factory preset temperature, 35°F for refrigerators and -4°F for freezers
- Temperature setting range from 33°F to 54°F for refrigerators and -10°F to 54°F for freezers
- Easy to read digital temperature display
- Easy to program push-button temperature control
- Microchip digital control and monitoring system with a variety of functions to monitor and maintain optimum temperature



Dimensions

ABS Legs



Two additional front adjustable stainless steel clad ABS legs for model EGS2 and EGSD2 to provide extra stability when opening and closing door, and one additional leg for model EGS6 for weight support.



Equipped with 9 ft long NEMA 5-15P plug.

Side view

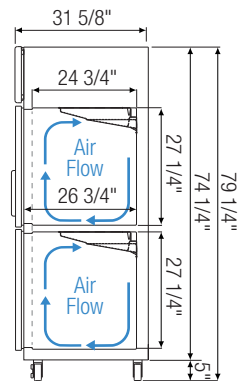

EGSDH2

Side view

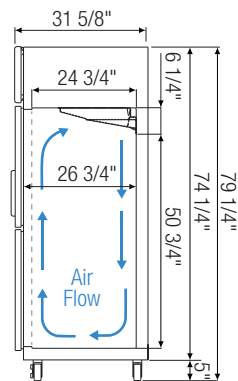

EGSH2, EGS4, EGSDH4, EGS6

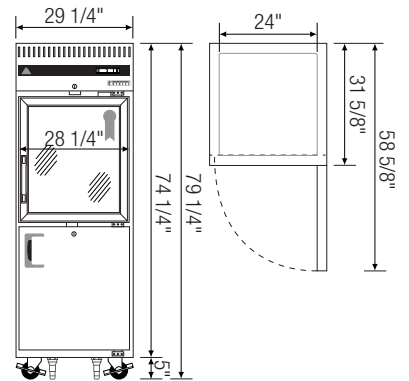

▲ EGS2

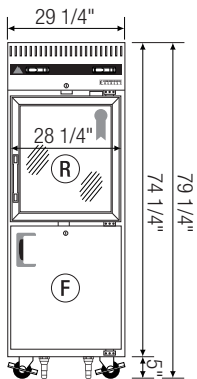
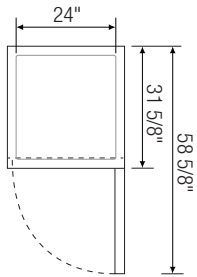

▲ EGS2H2 (Dual Temp)

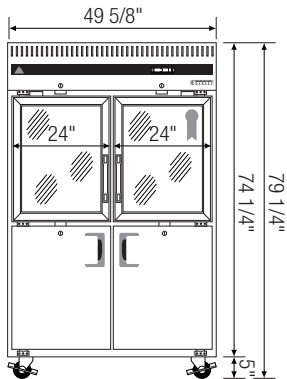
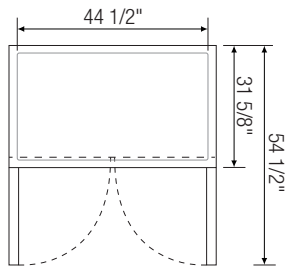

▲ EGS4

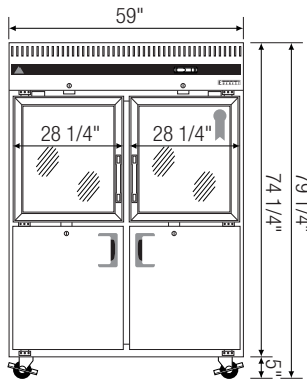
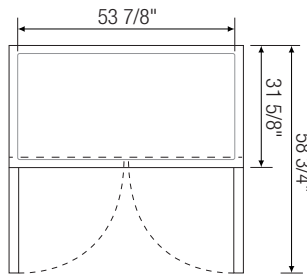

▲ EGS4H4

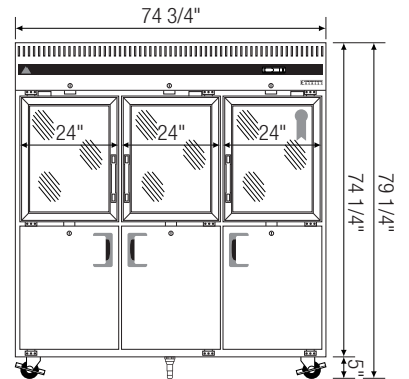
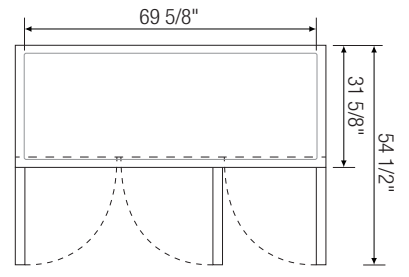

▲ EGS6

Model	Ref/ Frz/ Dual	# of Doors	Capacity (Cu.Ft.)	HP	Refrigerant	BTU/HR †	# of Shelves	Power (V-Hz-Ph)	Amps	Crated Weight (LBS)	Exterior Dimensions (Inches)			Interior Dimensions (Inches)		
											L	D ^a	H*	L	D	H
EGS2	Ref	2 (H)	23	1/3	R-134A	2,041	4	115-60-1	5.50	320	29 1/4	31 5/8	74 1/4	24	26 3/4	57
EGSDH2	Dual	2 (H)	11 (R) 11 (F)	1/2	R-404A	3,435	4	115-60-1	7.57	342	29 1/4	31 5/8	74 1/4	24	26 3/4	27 1/4 (R) 27 1/4 (F)
EGS4	Ref	4 (H)	48	1/3+	R-134A	2,612	8	115-60-1	11.00	453	49 5/8	31 5/8	74 1/4	44 1/2	26 3/4	57
EGSDH4	Ref	4 (H)	55	1/3+	R-134A	2,612	8	115-60-1	11.00	490	59	31 5/8	74 1/4	53 7/8	26 3/4	57
EGS6	Ref	6 (H)	71	1/3+ x 2	R-134A	2,612 x 2	12	115-60-1	9.49	620	74 3/4	31 5/8	74 1/4	69 5/8	26 3/4	57

* : Height does not include 5" for casters.

† : Based on evaporating temperature of 14°F (-10°C) & condensing temperature of 131°F (55°C).

a : Exterior depth dimension does not include 1-1/2" for door handles.

Ref = Refrigerator | Dual = Ref & Frz Combo
(H) = Half Door | (R) = Refrigerator | (F) = Freezer

Specifications subject to change without notice.

Product dimensions are for general purposes and not absolute value. Product capacity(▶) is calculated based on standard industry figures. Slight variations may exist. If dimensions and capacity are critical, please contact Everest Refrigeration.



Please visit our website for updated Energy Efficiency information.