

APPLICATION:

PRODUCT NAME:  
 ULTRA SPRAY VALVE

JOB NAME:

SPECIAL CONFIGURATION  
 CHECK BASE MODEL AND OPTIONS

QUANTITY:

ITEM NO.

MODEL:  
 2949 W/ 1.15 GPM NOZZLE

OPTIONS OR MODIFICATIONS:  
 OTHER \_\_\_\_\_

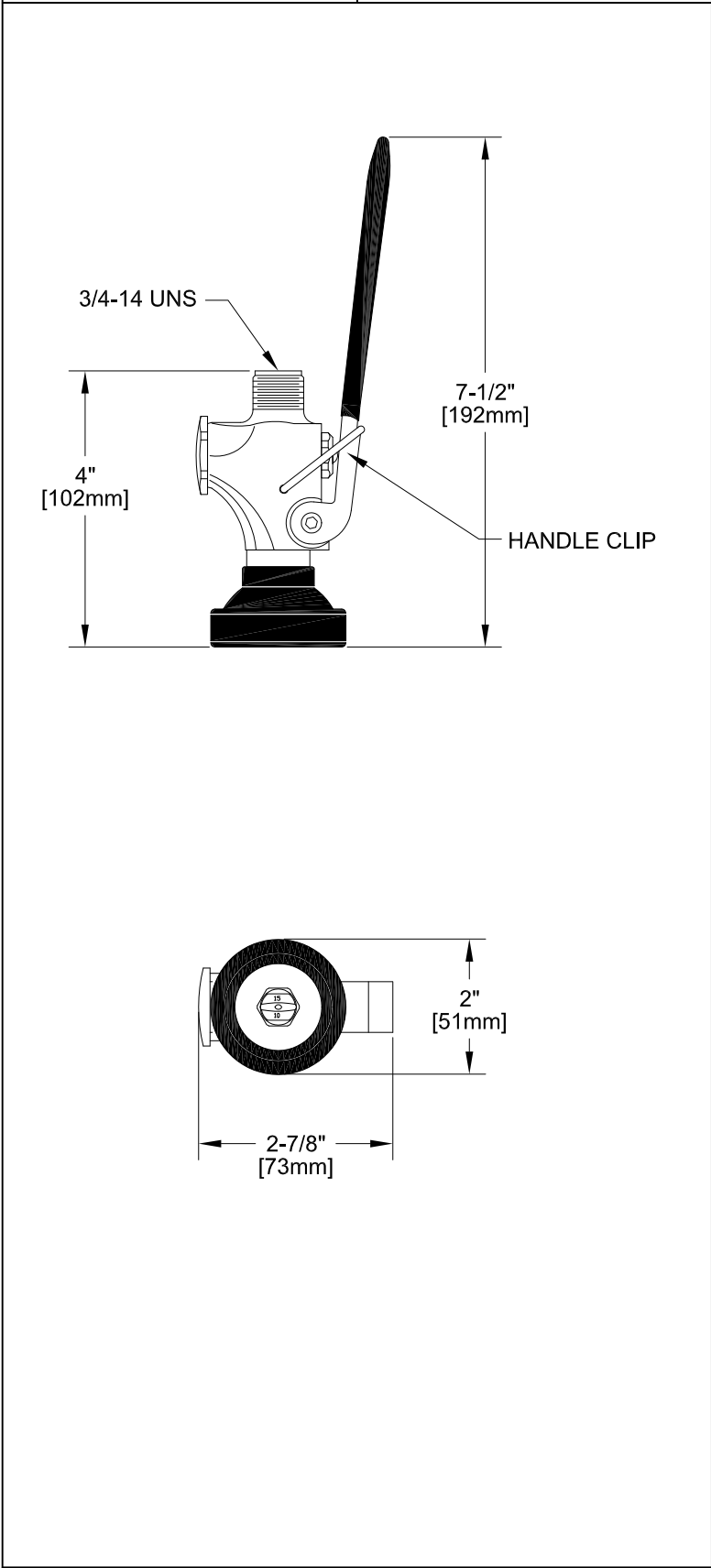

FEATURES

ULTRA SPRAY VALVE  
 \* LOWEST ENERGY USER - 1.15 GPM @ 60 PSI  
 \* CLEANS FASTER - TEST PROVEN  
 \* ENGINEERED TO LAST - NO 'O' RINGS TO LEAK  
 \* INTERCHANGEABLE - FITS ALL BRANDS

SYSTEM LIMITS  
 \* TEMP: 40°F MIN. TO 140°F MAX.  
 \* PRESSURE: 200 PSI MAX. STATIC  
 \* 1.15 GPM AT 60 PSI

SHIPPING WEIGHT  
 \* 1.5 LBS

EPAct 2005 Compliant  ANSI/A112.18.1M

**FISHER**  
 FISHER MANUFACTURING COMPANY  
 TOLL FREE: 800-421-6162 - FAX: 800-832-8238  
 information@fisher-mfg.com - www.fisher-mfg.com