

APPLICATION:

JOB NAME:

QUANTITY:                      ITEM NO.:

PRODUCT NAME:

**ELECTRONIC SENSOR SD**

MODEL:

- 74016    ELECTRONIC SENSOR BS 0.35 GPM
- 73751    ELECTRONIC SENSOR BS 0.50 GPM
- 74011    ELECTRONIC SENSOR BS 1.00 GPM
- 74017    ELECTRONIC SENSOR BS 1.50 GPM
- 74010    ELECTRONIC SENSOR BS 1.80 GPM
- 74009    ELECTRONIC SENSOR BS 2.20 GPM
- 74018    ELECTRONIC SENSOR BS 5.00 GPM

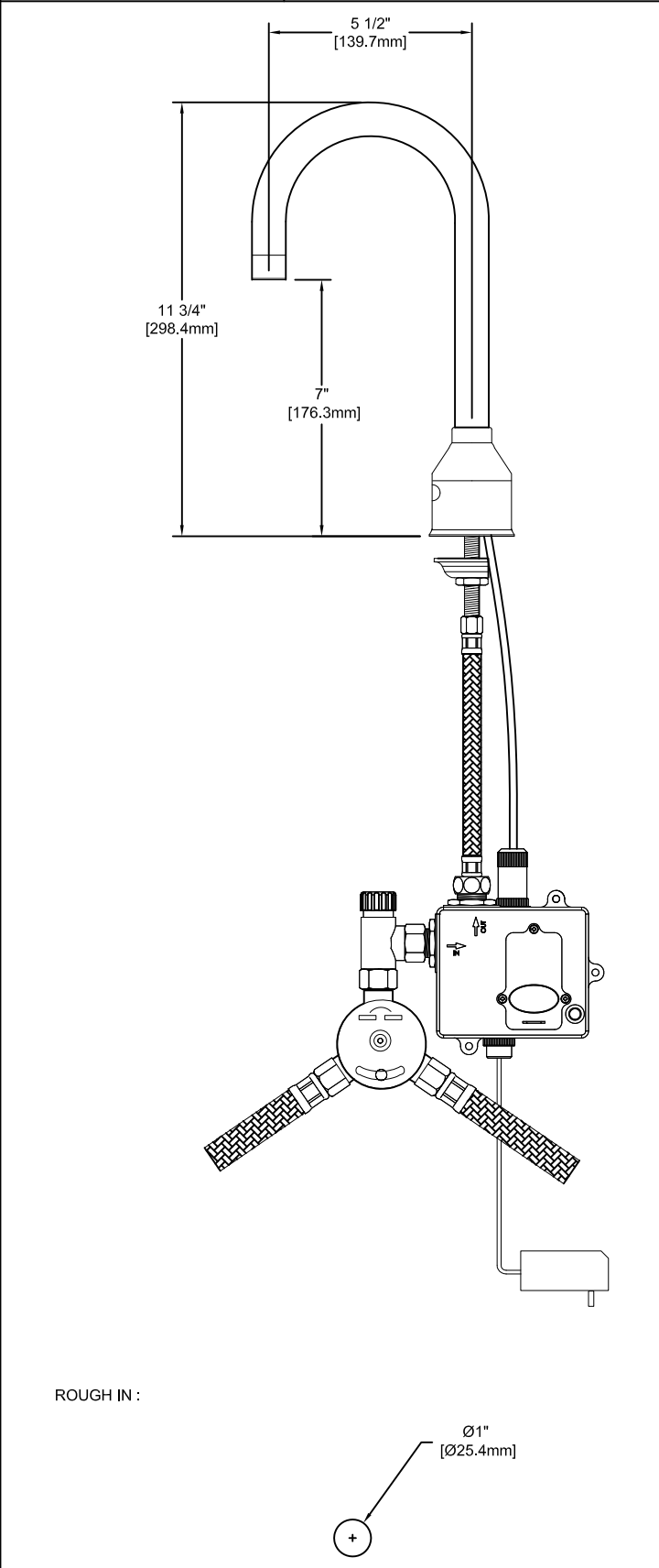

OPTIONS OR MODIFICATIONS:

OTHER \_\_\_\_\_

- FEATURES:
- \* AUTOMATIC SENSOR FAUCET
  - \* LOW LEAD BRASS WITH CHROME PLATING
  - \* BATTERY INCLUDED FOR DC USE
  - \* POWER SUPPLY INCLUDED FOR AC USE
  - \* FRESH BATTERY LIFE UP TO 500,000 CYCLES
  - \* LOW BATTERY INDICATOR: RED LIGHT FLASH
  - \* 3 BRAIDED SUPPLY LINES
  - \* MECHANICAL MIXING VALVE

SYSTEM LIMITS

- \* TEMP: 40°F MIN. TO 160°F MAX.
- \* PRESSURE 200 PSI MAX. STATIC

SHIPPING WEIGHT

- \* 8.0 LBS



**WARNING:**  
Proposition 65 requires that we provide you with the following notice: "This product Contains A Chemical Known To The State Of California To Cause Cancer Or Birth Defects Or Other Reproductive Harm."

