

Project _____
 Item _____
 Quantity _____
 CSI Section 11400
 Approval _____
 Date _____

Models
 NXP-HTD



Standard Features

- Built-in 70 °F (38.9 °C) rise booster heater with Sani-Sure™ final rinse system
- Automatic tank fill
- Door-actuated start
- Digital temperature display
- Delime cycle
- 17-1/4" (438 mm) vertical chamber clearance
- Specially designed stainless steel nozzles provide superior cleaning action
- Interchangeable upper and lower wash/rinse arms
- 1 hp stainless steel wash pump motor
- Vent fan control - shuts vent fan off when machine is idle
- Top mounted controls for ease of operation
- Large scrap basket
- Low watt density electric wash tank heater
- Hi-limit thermostat and low water protection
- Detergent/rinse additive signal connection fuse box
- Adjustable bullet feet

Mandatory Specs

Specify:
 Voltage _____

Options

- Single Phase
- Pressure Regulator
- Drain Water Tempering Kit
- Scaltrol
- Water Hammer Arrestor
- Flanged Feet
- False Panel (for corner installations)

Accessories

- 36-Compartment Rack
 - 4-1/8" tall (105 mm)
 - 5-5/8" tall (143 mm)
 - 7" tall (178 mm)
- Combination Rack
- Peg Rack

Specifications

- Uses 0.89 gallons (3.3 liters) of water per rack
- Total automatic cycle - 57 seconds
- 63 (58)* racks per hour
- Built-in 70 °F (38.9 °C) rise booster heater
- 1 hp stainless steel wash pump motor
- Single point connections for all utilities
- Field convertible from straight through to corner and vice versa (kit required)

- Field convertible from 3-phase to single-phase and vice versa (kit required)
- Durable stainless steel construction
- Uses standard 20" X 20" (508 mm X 508 mm) racks
- 1-year parts and labor warranty

*Racks per hour calculated with NSF suggested load time of five (5) seconds for door-type (straight thru)



Intertek



Intertek



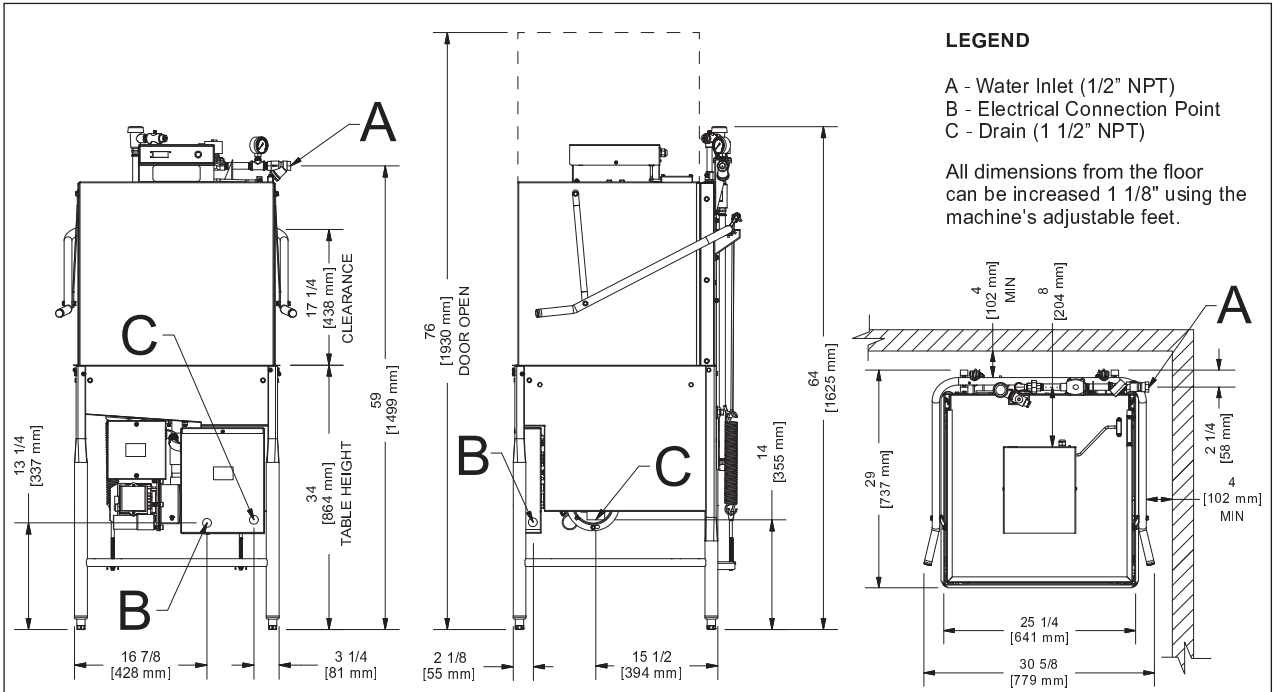

MODEL NO.	MACHINE DIMENSIONS				DRAIN HEIGHT	SHIPPING INFORMATION					
	HEIGHT	WIDTH	WIDTH BETWEEN TABLES	DEPTH		WEIGHT	CLASS	CUBE	HEIGHT	WIDTH	DEPTH
NXP-HTD	64" (1625 mm)	30-5/8" (779 mm)	25-1/4" (641 mm)	29" (737 mm)	14" (355 mm)	263 lbs (119 kg)	200	58.15 cu. ft.	72.5" (1842 mm)	33" (839 mm)	42" (1067 mm)

DIMENSION REQUIREMENTS	
Wall Clearance - Rear (minimum)	4" (102 mm)
Wall Clearance - Corner Installation Side (minimum)	4" (102 mm)
Standard Table Height	34-1/4" (871 mm)
Inside Clearance	17-1/4" (438 mm)
Machine Height with Door Open	76" (1930 mm)

WATER REQUIREMENTS	
Inlet Water Temperature	110 °F (43 °C)
Gallons per Hour	56.1 gal (212.4L)
Gallons per Hour**	51.7 gal (195.7L)
Gallons per Rack	.89 gal (3.3 L)
Waterline Size IPS (minimum)	1/2"
Drainline Size IPS (minimum)	1- 1/2"
Wash Tank Capacity	8 gal (30 L)
Booster Tank Capacity	1.66 gal (6.29 L)

OPERATING CAPACITY	
Racks per Hour	63 (58)*

ELECTRICAL REQUIREMENTS				
	Power Supply	Total Load	Minimum Circuit Ampacity	Maximum Overcurrent Protection
	208/60/3	45.6 A	46.8 A	50 A
	230/60/3	49.8 A	51.1 A	55 A
	208/60/1	75.2 A	76.5 A	80 A
	230/60/1	82.7 A	83.9 A	85 A

OPERATING CYCLE (seconds)				
	Wash	Rinse	Dwell	Total Cycle
	40	13	4	57

OPERATING TEMPERATURES	
Wash (minimum)	150 °F (66 °C)
Rinse (minimum)	180 °F (82 °C)

WASH PUMP MOTOR	
Wash Pump Motor Horsepower	1 HP

HEATERS		
	Volts	KW
Wash Heater	208V	4.1
	230V	5.0
Electric Rinse Tank Heater - 70°F (38.9°C) Rise	208V	10.5
	230V	12.9

The NXP carries the standard Jackson one (1) year warranty, but is not eligible for:

- Complimentary Start-up
- Extended warranties
- Bonus 6-month warranty when installed by a Jackson ASA

HOW TO SPECIFY: NXP-HTD

*Racks per hour calculated with NSF suggested load time of five (5) seconds for door-type (straight thru)
 **Gallons per hour calculated with NSF suggested load time of five (5) seconds for door-type (straight thru)

Jackson WWS, Inc.
 Shipping Address: 6209 North U.S. Highway 25E, Gray, KY 40734
 Mailing Address: P.O.Box 1060, Barbourville, KY 40906
 Telephone: 888-800-5672 • Fax: 606-523-1799
 Email: info@jacksonwws.com
 07610-004-90-31 [10/28/2020]

www.jacksonwws.com