



"ST6-SBK" Stainless Steel Top Work Tables

w/ 16 Gauge Stainless Steel Work Top
w/ Stainless Base & Adjustable Bracing



Item #	_____	Qty	_____
Model #	_____		
Project	_____		

16 GAUGE TOP w/ ADJUSTABLE BRACING					
24"WIDE	Qty	30"WIDE	Qty	36"WIDE	Qty
ST6-2436SBK		ST6-3036SBK		ST6-3636SBK	
ST6-2448SBK		ST6-3048SBK		ST6-3648SBK	
ST6-2460SBK		ST6-3060SBK		ST6-3660SBK	
ST6-2472SBK		ST6-3072SBK		ST6-3672SBK	
ST6-2484SBK		ST6-3084SBK		ST6-3684SBK	
ST6-2496SBK		ST6-3096SBK		ST6-3696SBK	
ST6-24108SBK		ST6-30108SBK		ST6-36108SBK	
ST6-24120SBK		ST6-30120SBK		ST6-36120SBK	

FEATURES:

- * 16 Gauge Stainless Steel Top
Type 300 stainless steel with # 3 polish, satin finish
- * Top is **Sound Deadened**
- * Reinforced with 1"x2" channel running entire length of table
- * 1 1/2" **Stallion Edge** on front and rear with side edges 90 degree bend down for table line-up
- * Stainless Base with **Adjustable** Bracing
- * Adjustable bullet feet
- * Shipped knocked-down, easy - to - assemble
- * NSF Approved



Adjustable Bracing

CONSTRUCTION:

Top: Stainless Steel Tops are TIG welded, Exposed welds are polished to match adjacent surface.

MATERIAL:

Top: 16 gauge stainless steel
Type 300 stainless steel with # 3 polish, satin finish

Bracing: 1 1/4" Round O.D. 18 gauge stainless steel

Legs: 1 5/8" Round O.D., 16 gauge tubular stainless steel

Gussets: Stainless Steel

Feet: 1" adjustable stainless bullet feet

OPTIONAL ACCESSORIES

	MODEL #	Qty
DRAWER		
DRAWER LOCK		
CASTERS		
OVERSHELVES		
SINKS		
POT RACK		

John Boos & Co

315 South First Street - Effingham, IL 62401
Phone: 217-347-7701 - Fax: 217-347-7705
Email: sales@johnboos.com - Web-site: www. johnboos.com

DETAILED SPECIFICATIONS

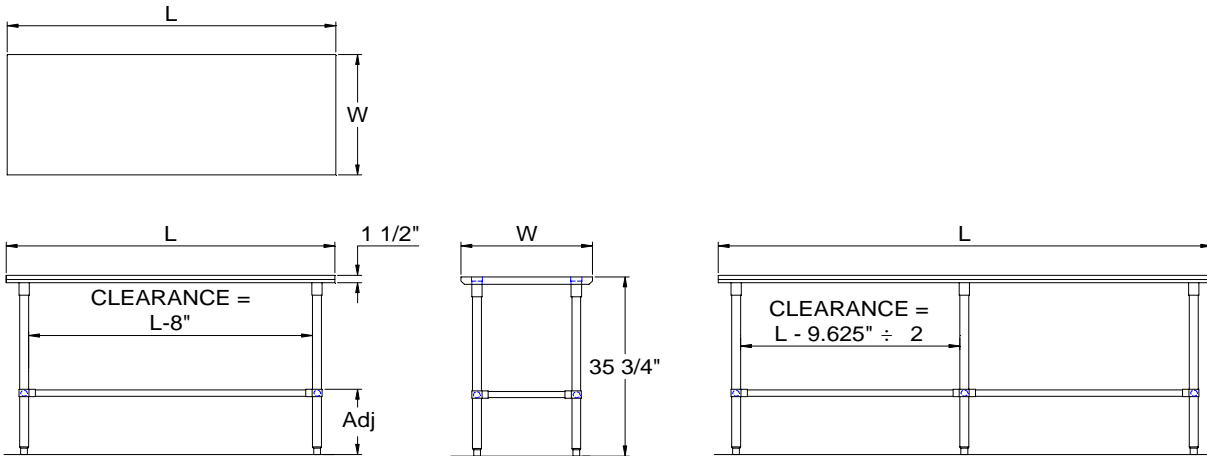

All units ship unassembled for reduced shipping cost.
 Units 7 ft. and larger are furnished with six legs.
 All dimensions are typical.
 Tolerance +/- .500".

Finished size of undershelf.
 Shelf length = length minus 4.875"
 Shelf width = width minus 4.25"

16 GAUGE TOP & UNDERSHELF

L	24" WIDE	WT.	30" WIDE	WT.	36" WIDE	WT.
36	ST6-2436SBK	46	ST6-3036SBK	50	ST6-3636SBK	60
48	ST6-2448SBK	54	ST6-3048SBK	60	ST6-3648SBK	66
60	ST6-2460SBK	63	ST6-3060SBK	70	ST6-3660SBK	77
72	ST6-2472SBK	72	ST6-3072SBK	80	ST6-3672SBK	89
84	ST6-2484SBK	85	ST6-3084SBK	94	ST6-3684SBK	104
96	ST6-2496SBK	97	ST6-3096SBK	108	ST6-3696SBK	119
108	ST6-24108SBK	106	ST6-30108SBK	118	ST6-36108SBK	130
120	ST6-24120SBK	114	ST6-30120SBK	128	ST6-36120SBK	141

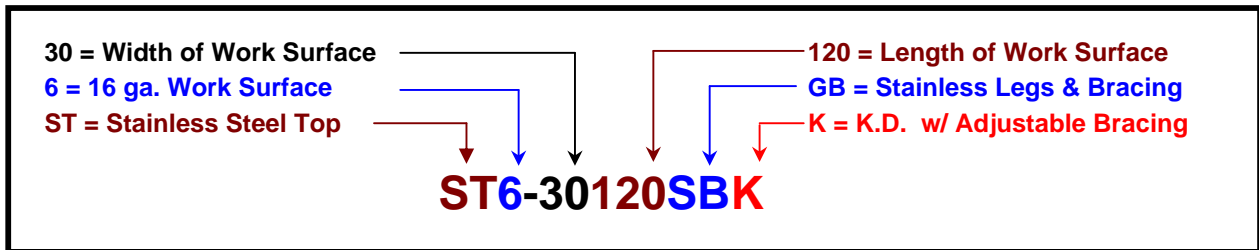

John Boos & Co

315 South First - Effingham, IL 62401 Phone: 217-347-7701 - Fax: 217-347-7705
 Email: sales@johnboos.com - Web-site: www.johnboos.com



June 2009

John Boos is constantly engaged in a program of improving products and therefore reserves the right to change specification without prior notice