



**John
BOOS**
Since 1887

ITEM #: _____ QTY: _____

MODEL #: _____

PROJECT NAME: _____

052118

3601 S. Banker St. Effingham, IL 62401 • P.O. BOX 609 • Ph: (888) 431-2667 • Fax: (800) 433-2667

"B" BLACK METAL TABLE BASES

FEATURES:

- TABLE BASES HAVE CAST IRON CONSTRUCTION AND COME IN BOTH DINNING AND BAR HEIGHTS.
- OPTIONS OF THREE DIFFERENT STYLES ARE AVAILABLE: ROUND BASE, STRAIGHT BASE, OR CROSS BASE
- BAR HEIGHT ADD (40) SUFFIX TO MODEL NUMBER



2015B



2065B



1917B



2015B40-F

BLACK METAL TABLE BASES

MODEL #	QTY
1917B	
1922B	
1930B	
2015B	
2025B	
2065B	
2065B1	
2065B3	
2099B	

DETAILED SPECIFICATIONS

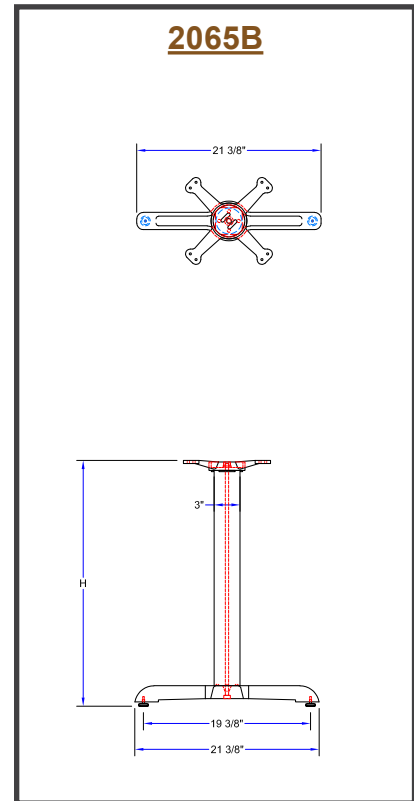
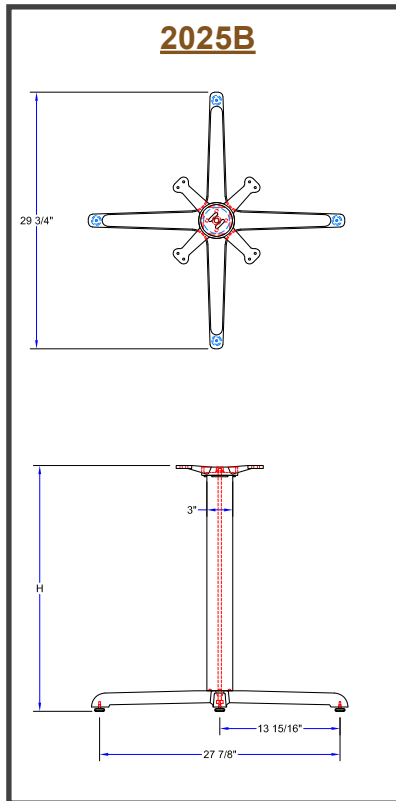
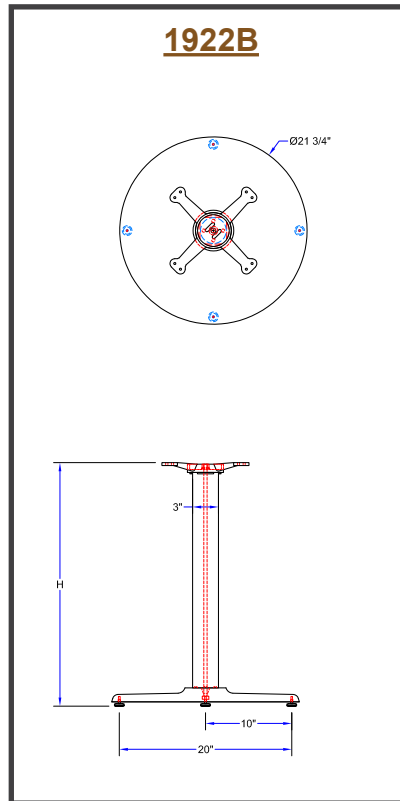

BLACK METAL TABLE BASES

MODEL #	RECOMMENDED TOP SIZE	BASE SPREAD	SPIDER SIZE	WEIGHT (LBS)
1917B	24" - 30"	18"DIA	13"	26
1922B	36" - 42" OR 30" - 42"	22"DIA	13"	35
1930B	48" - 60"	30"DIA	15"	50
2015B	24" - 30"	22" X 22"	13"	19
2025B	36" - 42"	30" X 30"	13"	22
2065B1	-	5" X 22"	13"	15
2065B	48" - 96" (SET 2)	5" X 22"	13"	30
2065B3	120" - 144" (SET 3)	5" X 22"	13"	45
2099B	OBLONG	24" X 30"	13"	21

SOME UNITS SHIP UNASSEMBLED FOR REDUCED SHIPPING COST. ALL DIMENSIONS ARE TYPICAL. TOLERANCE +/- .500"
 John Boos & Co. is constantly engaged in a program of improving products and therefore reserves the right to change specifications without prior notice.



3601 S. Banker St. • Effingham, IL 62401 • PO BOX 609 • quotes@johnboos.com

www.johnboos.com