



**TRUE FOOD SERVICE
EQUIPMENT, INC.**

2001 East Terra Lane • O'Fallon, Missouri 63366
 (636)240-2400 • Fax (636)272-2408 • (800)325-6152 • Intl Fax# (001)636-272-7546
 Parts Dept. (800)424-TRUE • Parts Dept. Fax# (636)272-9471 • www.truemfg.com

Project Name: _____

Location: _____

Item #: _____ Qty: _____

Model #: _____

A/A #

SIS #

Model:
T-23DT-G

T-Series:

Reach-In Glass Swing Door Dual Temperature Refrigerator/Freezer



T-23DT-G

- ▶ Designed using the highest quality materials and components to provide the user with colder product temperatures, lower utility costs, exceptional food safety and the best value in today's food service marketplace.
 - ▶ Refrigerator located in top section; freezer on bottom.
 - ▶ Equipped with two, self-contained, independent refrigeration systems. Oversized and factory balanced; refrigerator section holds 33°F to 38°F (.5°C to 3.3°C); freezer holds -10°F (-23.3°C).
 - ▶ Energy efficient, "Low-E", double pane thermal tempered glass doors in refrigerator section.
 - ▶ Energy efficient, triple pane thermal insulated glass doors in freezer section.
 - ▶ Adjustable, heavy duty PVC coated shelves.
 - ▶ Positive seal self-closing doors. Lifetime guaranteed door hinges and torsion type closure system.
- Bottom mounted units feature:**
- ▶ "No stoop" lower shelf.
 - ▶ Storage on top of cabinet.
 - ▶ Compressors perform in coolest, most grease free area of kitchen.
 - ▶ Easily accessible condenser coil for cleaning.

ROUGH-IN DATA

Specifications subject to change without notice.
 Chart dimensions rounded up to the nearest 1/8" (millimeters rounded up to next whole number).

Model	Doors	Shelves	Cabinet Dimensions (inches) (mm)			HP		Voltage	Amps	NEMA Config.	Cord Length (total ft.) (total m)	Crated Weight (lbs.) (kg)
			L	D†	H*	Ref.	Frz.					
T-23DT-G	2	3	27	29¾	78¾	½	½	115/60/1	15.6	5-20P	9	380
			686	756	1991	½	½	230-240/50/1	7.3	▲	2.74	173

† Depth does not include 1 3/8" (35 mm) for door handle.

* Height does not include 5" (127 mm) for castors or 6" (153 mm) for optional legs.

▲ Plug type varies by country.

	APPROVALS: 	AVAILABLE AT:
7/11	Printed in U.S.A.	

Model:
T-23DT-G

T-Series:
Reach-In Glass Swing Door Dual Temperature Refrigerator/Freezer



STANDARD FEATURES

DESIGN

- True's glass door reach-in's are designed with enduring quality that protects your long term investment.
- True's commitment to using the highest quality materials and oversized refrigeration systems provides the user with colder product temperatures, lower utility costs, exceptional food safety and the best value in today's food service marketplace.

REFRIGERATION SYSTEM

- Equipped with two, independent, factory engineered, self-contained, capillary tube refrigeration systems using environmentally friendly (CFC free) refrigerant. Refrigerator uses 134A and freezer uses R404A.
- Refrigerator located in top section; freezer on bottom.
- Extra large evaporator coils balanced with higher horsepower compressors and large condensers; maintain colder standard temperatures for the best in food preservation. Refrigerator holds 33°F to 38°F (.5°C to 3.3°C); freezers holds -10°F (-23.3°C).
- Sealed, cast iron, self-lubricating evaporator fan motors and larger fan blades give True reach-in's a more efficient, low velocity, high volume airflow design. This unique design ensures faster temperature recovery and shorter run times in the busiest of food service environments.
- Bottom mounted condensing units positioned for easy cleaning. Compressors run in coolest and most grease free area of the kitchen. Allows for storage area on top of unit.
- Automatic freezer defrost system is time-initiated, time-terminated.

CABINET CONSTRUCTION

- Exterior - Stainless steel front. Anodized quality aluminum ends, back and top.
- Interior - attractive, NSF approved, white aluminum liner. Stainless floor with coved corners.
- Insulation - entire cabinet structure is foamed-in-place using Ecomate. A high density, polyurethane insulation that has zero ozone depletion potential (ODP) and zero global warming potential (GWP).
- Welded, heavy duty steel frame rail, black powder coated for corrosion protection.
- Frame rail fitted with 4" (102 mm) diameter stem castors - locks provided on front set.

DOORS

- "Low-E", double pane thermal glass assembly in refrigerator door. Triple pane thermal glass assembly in freezer door.
- Extruded aluminum frames. Door locks standard.
- Each door fitted with 15" (381 mm) long extruded aluminum handle.
- Positive seal self-closing doors. Lifetime guaranteed door hinges and torsion type closure system.
- Magnetic door gaskets of one piece construction, removable without tools for ease of cleaning.

SHELVING

- Three (3) adjustable, heavy duty PVC coated wire shelves 22 7/8" L x 23 1/4" D (582 mm x 591 mm). Four (4) chrome plated shelf clips included per shelf.
- Shelf support pilasters made of same material as cabinet interior; shelves are adjustable on 1/2" (13 mm) increments.

LIGHTING

- Compartmentalized, fluorescent interior lighting (one per section). Door utilizes full-length, patented, integrated door light (IDL) system. Safety shielded.

MODEL FEATURES

- Two (2) exterior digital temperature displays, one for refrigerator section and one for freezer.
- Evaporator is epoxy coated to eliminate the potential of corrosion.
- Minimum wattage heater in cabinet frame and freezer door.
- NSF-7 compliant for open food product.

ELECTRICAL

- Unit completely pre-wired at factory and ready for final connection to a 115/60/1 phase, 20 amp dedicated outlet. Cord and plug set included.



OPTIONAL FEATURES/ACCESSORIES

Upcharge and lead times may apply.

- 230 - 240V / 50 Hz.
- 6" (153 mm) standard legs.
- 6" (153 mm) standard or seismic/flanged legs.
- Additional shelves.
- Novelty baskets.
- Half door bun tray racks (refrigerator section only). Each holds up to eleven 18"L x 26"D (458 mm x 661 mm) sheet pans (sold separately).
- Remote cabinets (condensing unit supplied by others; system comes standard with 404A expansion valve and requires R404A refrigerant). Consult factory technical service department for BTU information. All remote units must be hard wired during installation.

PLAN VIEW

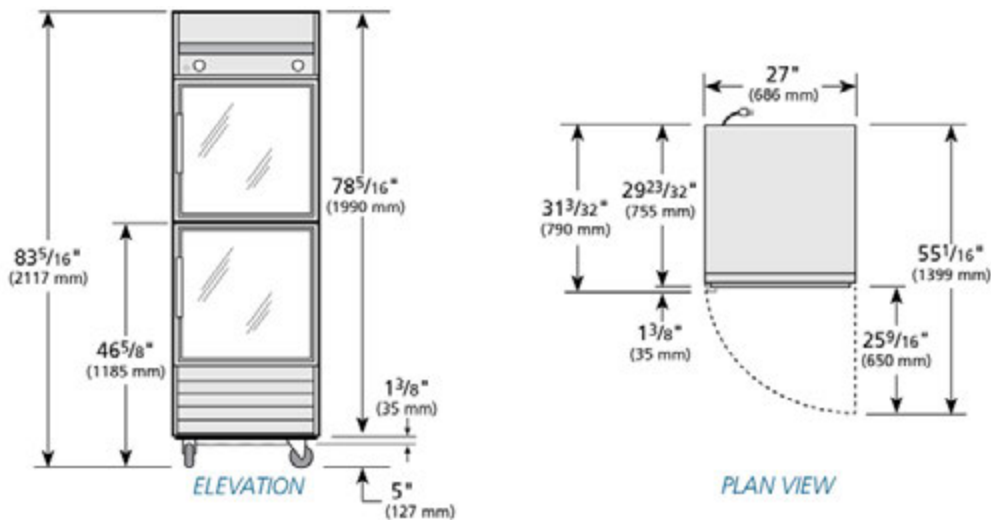

WARRANTY
One year warranty on all parts and labor and an additional 4 year warranty on compressor. (U.S.A. only)

METRIC DIMENSIONS ROUNDED UP TO THE NEAREST WHOLE MILLIMETER
SPECIFICATIONS SUBJECT TO CHANGE WITHOUT NOTICE

	Model	Elevation	Right	Plan	3D	Back
	T-23DT-G	TFEY65E	TFGY085	TFEY06P	TFEY653	

TRUE FOOD SERVICE EQUIPMENT

2001 East Terra Lane • O'Fallon, Missouri 63366 • (636)240-2400 • Fax (636)272-2408 • (800)325-6152 • Intl. Fax# (001)636-272-7546 • www.truefmfg.com