



**U.S.A FOODSERVICE
DIVISION**

TRUE MANUFACTURING CO., INC.

2001 East Terra Lane • O'Fallon, Missouri 63366-4434 • (636)240-2400
 Fax (636)272-2408 • Toll Free (800)325-6152 • Intl Fax# (001)636-272-7546
 Parts Dept. (800)424-TRUE • Parts Dept. Fax# (636)272-9471 • www.truemfg.com

Model:

TBR48-RISZ1-L-B-SS-1

**True Bar Refrigerator:
Reach-In Single Zone Refrigerator**

PROJECT NAME

LOCATION

ITEM #

QTY

AIA #

MODEL #

SIS #



FEATURES

- ▶ R290 Hydrocarbon refrigerant.
- ▶ Temperatures of 33°F to 38°F (.5°C to 3.3°C)
- ▶ Exterior: Black powder coated cold rolled steel with stainless steel countertop
- ▶ Interior: Stainless steel
- ▶ RCU Technology
- ▶ White LED interior lighting
- ▶ NSF/ANSI standard 7 compliant for open food product
- ▶ UL Rated for outdoor use
- ▶ Three (3) interior access ports
- ▶ Field reversible doors
- ▶ Zero clearance (side and back)
- ▶ Front air intake / front air discharge
- ▶ Electronic temperature control with exterior digital display

ROUGH-IN DATA

Specifications subject to change without notice.
 Chart dimensions rounded up to the nearest 1/8" (millimeters rounded up to next whole number).

Model	Doors	Shelves	Capacity		Cabinet Dimensions (inches) (mm)			115V/60/1 Voltage			Cord Length‡ (total ft.) (total m)	Crated Weight (lbs.) (kg)
			12 oz. Cans	12 oz. Bottles	W	D†	H	HP	Amps	NEMA		
TBR48-RISZ1-L-B-SS-1	2	6	76 6-pks	43 6-pks	48 1219	24 7/8 631	34 3/4 881	1/2	1.8	5-15P	10 3.04	405 184

† Depth does not include 1 1/2" (35 mm) for door handles. * Height does not include 1/4" (7 mm) for leg levelers
 ‡ Cord length listed represents usable cord length.



APPROVALS:

AVAILABLE AT:

Model:

TBR48-RISZ1-L-B-SS-1

True Bar Refrigerator: Reach-In Single Zone Refrigerator



ADDITIONAL FEATURES

REFRIGERATION SYSTEM

- Factory engineered, self-contained, capillary tube system
- Environmentally friendly R290 hydrocarbon refrigerant
- Forced air refrigeration system which maintains 33°F to 38°F (5°C to 3.3°C) product temperatures
- Exclusive RCU technology allows for the reversing of the condenser fan motor, helping to keep the condensing coil clean and reduce the negative effects of a dirty coil

CABINET CONSTRUCTION

- Exterior: Black, powder coated cold-rolled steel with stainless steel countertop
- Interior: Stainless steel floor and sides with ABS plastic ceiling
- Insulation: Entire cabinet is foamed-in-place using a high density, polyurethane insulation that has zero ozone depletion and zero global warming potential
- Base fitted with leg levelers

DOORS

- Door locks standard
- Field Reversible Doors standard (reverse hinge kit included)

SHELVING

- Six (6) adjustable, gray PVC coated wire shelves. 15 1/2"W x 18"D (394 mm x 458 mm). Four (4) chrome plated shelf clips included per shelf.
- Aluminum shelf support pilasters. Shelves are adjustable on 1/2" (13 mm) increments.

MODEL FEATURES

- NSF/ANSI Standard 7 compliant for open food
- UL approved for outdoor use
- Electronic temp control with exterior digital display
- Three (3) access ports standard (see drawing for locations)

ELECTRICAL

- Unit completely pre-wired at factory and ready for final connection to a 115/60/1 phase, 15 amp dedicated outlet. Cord and plug set included.



115/60/1
NEMA-5-15R

OPTIONAL FEATURES/ACCESSORIES

 Upcharge and lead times may apply.

- TruLumina® 14-Color LED lighting
- Castors: 7/8" (23 mm) rollers, 2" (51mm), 3" (77mm), 4" (102mm), 5" (127mm) castors
- 6" (153mm) legs
- 6" (153mm) seismic legs
- Alternative temperature zones available (contact factory)

PLAN VIEW

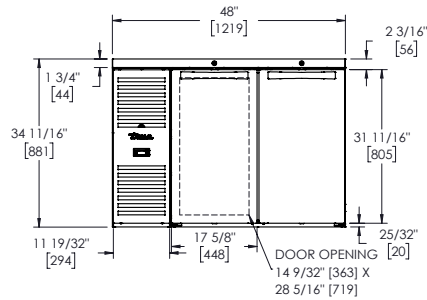

FRONT VIEW

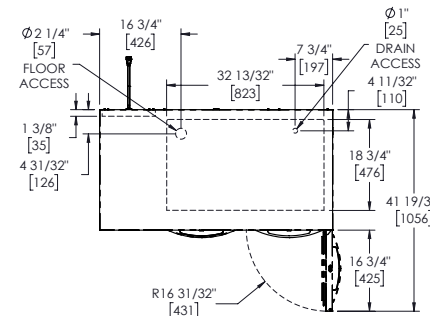

TOP VIEW

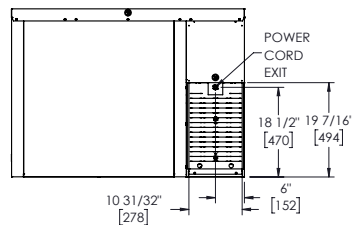

BACK VIEW

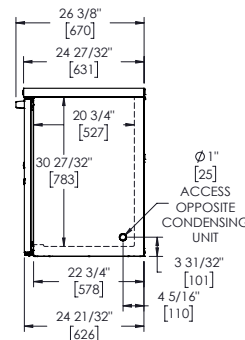

SIDE VIEW

PLAN VIEW NOTES

- Dimensions in brackets are in millimeters.
- Depth does not include 1 1/2" (35 mm) for door handles.
- Height does not include 1/4" (7 mm) for leg levelers

WARRANTY

Three year warranty on all parts and labor and an additional 2 year warranty on compressor. (U.S.A. only)

SPECIFICATIONS SUBJECT TO CHANGE WITHOUT NOTICE
METRIC DIMENSIONS ROUNDED UP TO THE NEAREST WHOLE MILLIMETER

TRUE MANUFACTURING CO., INC.

2001 East Terra Lane • O'Fallon, Missouri 63366-4434 • (636)240-2400 • Fax (636)272-2408 • Toll Free (800)325-6152 • Intl. Fax# (001)636-272-7546 • www.truemfg.com



**U.S.A FOODSERVICE
DIVISION**

TRUE MANUFACTURING CO., INC.

2001 East Terra Lane • O'Fallon, Missouri 63366-4434 • (636)240-2400
 Fax (636)272-2408 • Toll Free (800)325-6152 • Intl Fax# (001)636-272-7546
 Parts Dept. (800)424-TRUE • Parts Dept. Fax# (636)272-9471 • www.truemfg.com

Model:

TBR48-RISZ1-L-S-SS-1

**True Bar Refrigerator:
Reach-In Single Zone Refrigerator**

PROJECT NAME

LOCATION

ITEM #

QTY

AIA #

MODEL #

SIS #



FEATURES

- ▶ R290 Hydrocarbon refrigerant.
- ▶ Temperatures of 33°F to 38°F (.5°C to 3.3°C)
- ▶ Exterior: Stainless steel
- ▶ Interior: Stainless steel
- ▶ RCU Technology
- ▶ White LED interior lighting
- ▶ NSF/ANSI standard 7 compliant for open food product
- ▶ UL Rated for outdoor use
- ▶ Three (3) interior access ports
- ▶ Field reversible doors
- ▶ Zero clearance (side and back)
- ▶ Front air intake / front air discharge
- ▶ Electronic temperature control with exterior digital display

ROUGH-IN DATA

Specifications subject to change without notice.
 Chart dimensions rounded up to the nearest 1/8" (millimeters rounded up to next whole number).

Model	Doors	Shelves	Capacity		Cabinet Dimensions (inches) (mm)			115V/60/1 Voltage			Cord Length‡ (total ft.) (total m)	Crated Weight (lbs.) (kg)
			12 oz. Cans	12 oz. Bottles	W	D†	H	HP	Amps	NEMA		
TBR48-RISZ1-L-S-SS-1	2	6	76 6-pks	43 6-pks	48 1219	24 7/8 631	34 3/4 881	1/2	1.8	5-15P	10 3.04	405 184

† Depth does not include 1 1/2" (35 mm) for door handles. * Height does not include 1/4" (7 mm) for leg levelers
 ‡ Cord length listed represents usable cord length.



APPROVALS:

AVAILABLE AT:

Model:

TBR48-RISZ1-L-S-SS-1

True Bar Refrigerator: Reach-In Single Zone Refrigerator



ADDITIONAL FEATURES

REFRIGERATION SYSTEM

- Factory engineered, self-contained, capillary tube system
- Environmentally friendly R290 hydrocarbon refrigerant
- Forced air refrigeration system which maintains 33°F to 38°F (5°C to 3.3°C) product temperatures
- Exclusive RCU technology allows for the reversing of the condenser fan motor, helping to keep the condensing coil clean and reduce the negative effects of a dirty coil

CABINET CONSTRUCTION

- Exterior: Stainless steel front, sides, and countertop
- Interior: Stainless steel floor and sides with ABS plastic ceiling
- Insulation: Entire cabinet is foamed-in-place using a high density, polyurethane insulation that has zero ozone depletion and zero global warming potential
- Base fitted with leg levelers

DOORS

- Door locks standard
- Field Reversible Doors standard (reverse hinge kit included)

SHELVING

- Six (6) adjustable, gray PVC coated wire shelves. 15 1/2"W x 18"D (394 mm x 458 mm). Four (4) chrome plated shelf clips included per shelf.
- Aluminum shelf support pilasters. Shelves are adjustable on 1/2" (13 mm) increments.

MODEL FEATURES

- NSF/ANSI Standard 7 compliant for open food
- UL approved for outdoor use
- Electronic temp control with exterior digital display
- Three (3) access ports standard (see drawing for locations)

ELECTRICAL

- Unit completely pre-wired at factory and ready for final connection to a 115/60/1 phase, 15 amp dedicated outlet. Cord and plug set included.



115/60/1
NEMA-5-15R

OPTIONAL FEATURES/ACCESSORIES

 Upcharge and lead times may apply.

- TruLumina® 14-Color LED lighting
- Castors: 7/8" (23 mm) rollers, 2" (51mm), 3" (77mm), 4" (102mm), 5" (127mm) castors
- 6" (153mm) legs
- 6" (153mm) seismic legs
- Alternative temperature zones available (contact factory)

PLAN VIEW

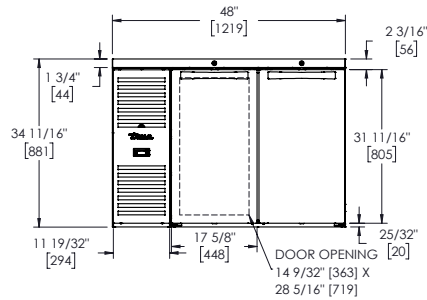

FRONT VIEW

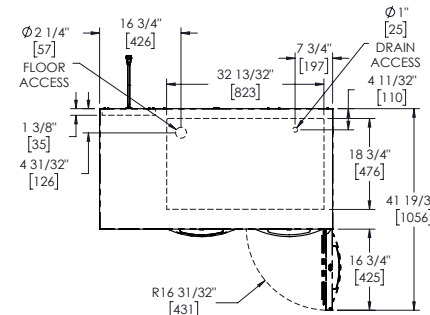

TOP VIEW

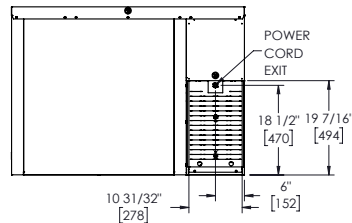

BACK VIEW

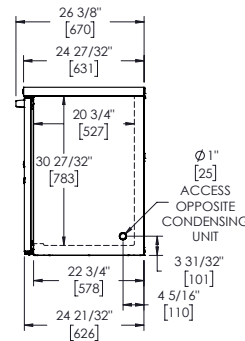

SIDE VIEW

PLAN VIEW NOTES

- Dimensions in brackets are in millimeters.
- Depth does not include 1 1/2" (35 mm) for door handles.
- Height does not include 1/4" (7 mm) for leg levelers

WARRANTY

Three year warranty on all parts and labor and an additional 2 year warranty on compressor. (U.S.A. only)

SPECIFICATIONS SUBJECT TO CHANGE WITHOUT NOTICE
METRIC DIMENSIONS ROUNDED UP TO THE NEAREST WHOLE MILLIMETER

TRUE MANUFACTURING CO., INC.

2001 East Terra Lane • O'Fallon, Missouri 63366-4434 • (636)240-2400 • Fax (636)272-2408 • Toll Free (800)325-6152 • Intl. Fax# (001)636-272-7546 • www.truemfg.com