



ALUMINUM
SANITIZER DISPENSER STAND
MODEL: SST-24

Item #: _____ Qty #: _____

Model #: _____

Project #: _____

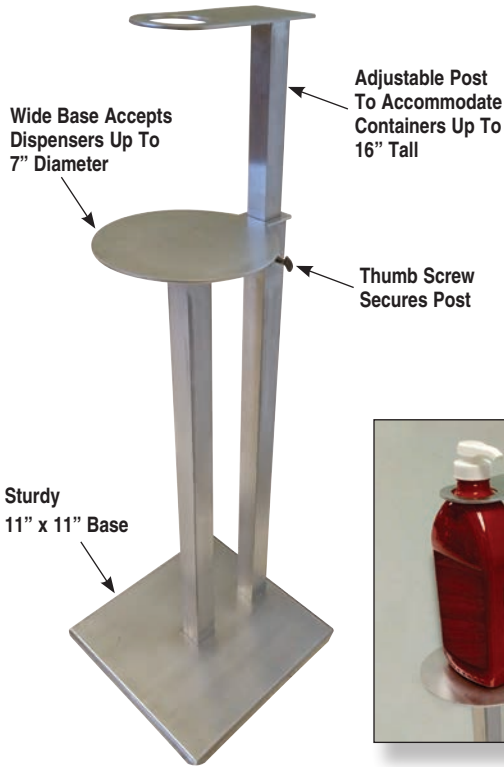

Shown Above With
1.5 Quart Container



Shown Above With
Gallon Container

FEATURES:

Adjustable to fit any height dispenser up to 16" tall. Accepts dispensers up to 7" diameter with less than 2" diameter throat. 11" x 11" base. Footprint minimizes space required. Support mechanism stabilizes dispenser container and prevents it from being knocked off the stand or easily stolen.

MATERIAL:

All Aluminum construction.

DIMENSIONS and SPECIFICATIONS

TOL ± .500"

ALL DIMENSIONS ARE TYPICAL

SST-24

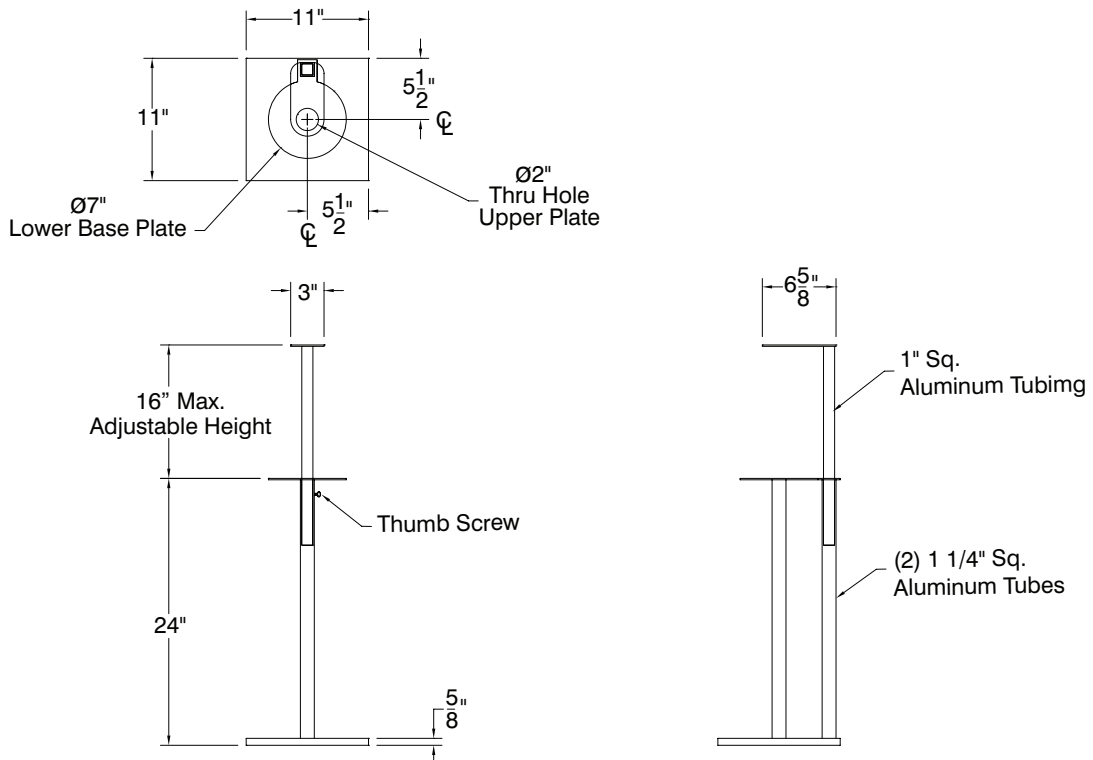

4 Lbs.