

TABLES with Undershaft

This package contains Table Top, Undershaft, Legs & Set Screws

Tool required for installation: 5/32 Allen wrench.

Step 1:

Lay the table top flat on the box to protect the finish during assembly. (Figure 1)

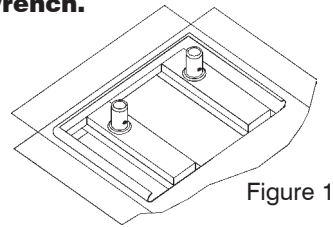

Figure 1

NSF Installations require all set screws filled with an approved silicone sealer.

Step 2:

Remove plastic cap from gusset. (Figure 2) Set screws are located inside gusset.

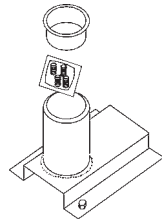

Figure 2

Step 3:

Insert set screws into adjustable shelf corner (underneath shelf). Insert legs into adjustable shelf corner and align with score marks on leg. Tighten set screws. (Figure 3) Shelf is adjustable.

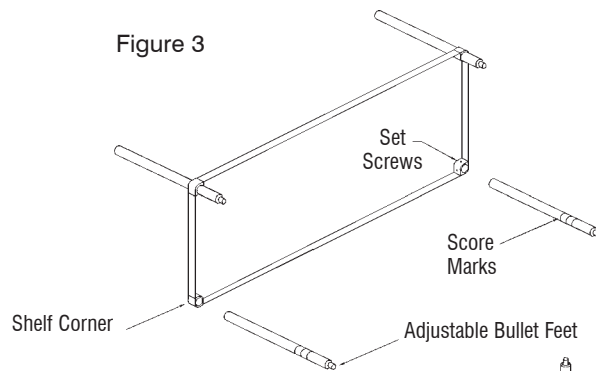

Figure 3

Step 4:

Insert legs and undershaft assembly into gussets as indicated in Figure 4. Tighten set screws.

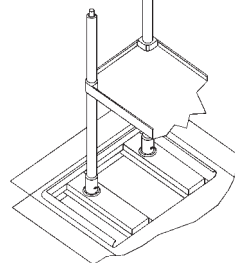

Figure 4

TABLES with Open Style Tubular Base

This package contains Table Top, Front Leg Assembly, Rear Leg Assembly & Fasteners

Tools required for installation: 5/32 Allen wrench and 7/32 Allen wrench

Step 1:

Lay the table top flat on the box to protect the finish during assembly. (Figure 1)

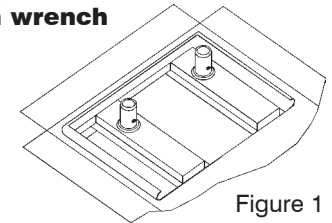

Figure 1

NSF Installations require all set screws filled with an approved silicone sealer.

Step 2:

Remove plastic cap from gusset. (Figure 2) Set screws are located inside gusset.

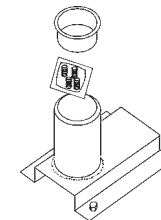

Figure 2

Step 3:

Align rear cross brace with hole at rear of "H" leg assembly and fasten using 3/8" - 16 x 2-1/2" stainless steel button head socket bolt and tighten. Seal hex head with NSF approved silicone sealant. (Figure 3)

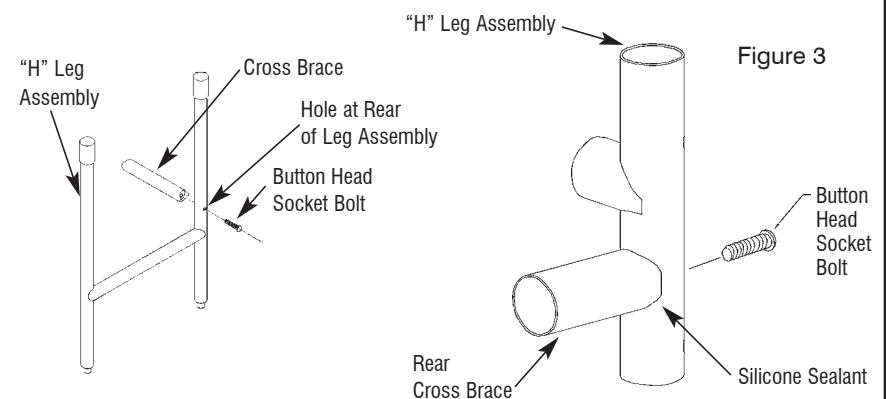

Figure 3

Step 4:

Insert leg assembly into gussets as indicated. (Figure 4)

Tighten all set screws.

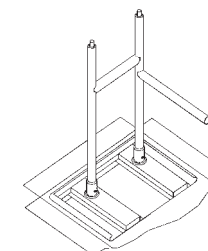

Figure 4

Follow same Installation Instructions for Tables
with 1½" Splash, 5" Splash or 10½" Splash

FINAL STEP

Turn table upright and level by adjusting bullet feet.

UNDERSHELF

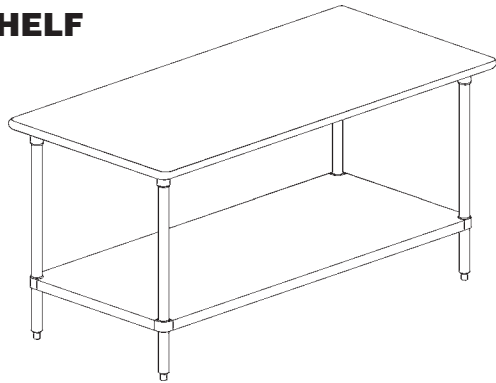

NSF Installations require all set screws filled
with an approved silicone sealer.

OPEN BASE

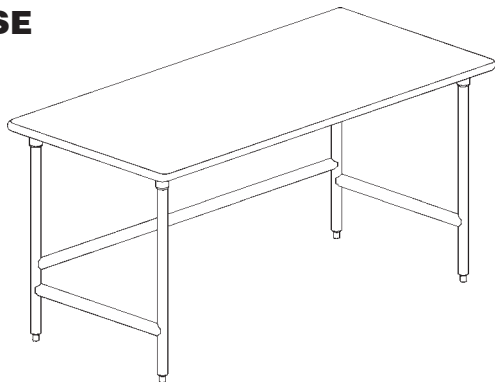

Edgewood, New York 11717-8380

1/02 TABLES



Installation Instructions for TABLES



Flat Top

1½" Splash



5" Splash



CHECK FOR CONCEALED DAMAGE
FILE CLAIM WITH DELIVERING FREIGHT CARRIER

Tables manufactured by **ADVANCE TABCO** are designed and constructed for applications including Food Preparation, Cooking, Manufacturing, Material Handling, Laboratory Service and the like. **ADVANCE TABCO** does not recommend product use for activities employing harsh and active chemicals. Consult factory regarding unusual applications.