

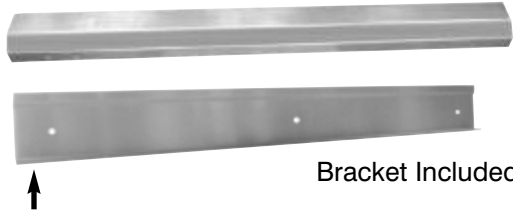

STAINLESS STEEL

WALL CORNER & BUMPER GUARDS



Bracket Included

WALL BUMPER GUARD

MODEL #	L	Width	Wt.
BG-48	48"	4"	13 lbs.
BG-60	60"	4"	19 lbs.

WALL CORNER GUARD

MODEL #	Length	Width	Wt.
CG-48	48"	2"	6 lbs.
CG-60	60"	2"	8 lbs.

Item #: _____ Qty #: _____

Model #: _____

Project #: _____

FEATURES:

Corner Guard: 48" long stainless steel corner guard with adhesive backing and 1/4" diameter holes on each end for easy installation.

Bumper Guard: Includes mounting bracket. Mounting bracket has 1/4" diameter holes for easy installation.

CONSTRUCTION:

One piece stainless steel with 1/8" radius on all corners.

MATERIAL:

Heavy gauge "304" stainless steel.

DETAILS and SPECIFICATIONS

TOL ± .500"

ALL DIMENSIONS ARE TYPICAL

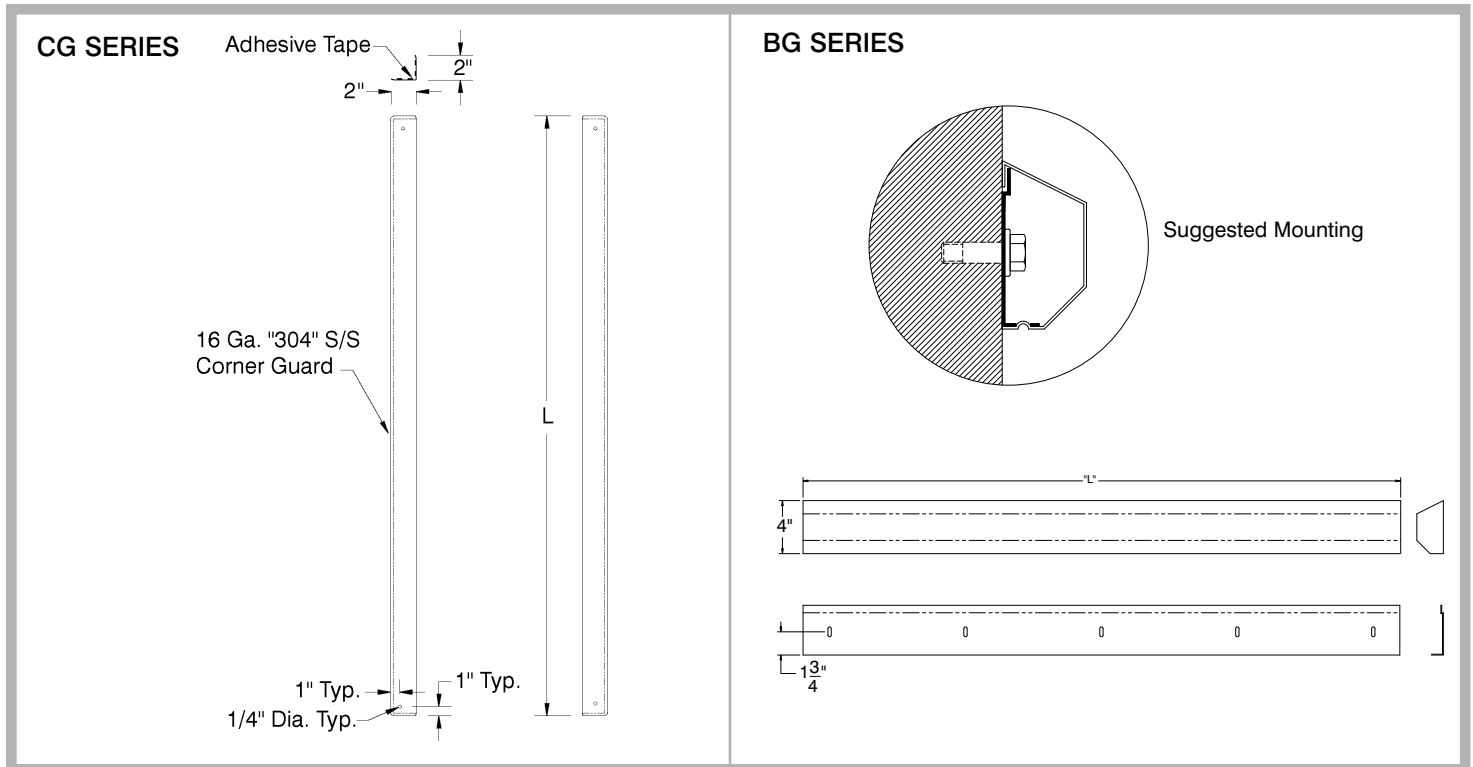

Customer Service Available To Assist You **1-800-645-3166** 8:30 am - 8:00 pm E.S.T.

Email Orders To: customer@advancetabco.com. For Smart Fabrication™ Quotes, Email To: smartfab@advancetabco.com or Fax To: 631-586-2933

NEW YORK
Fax: (631) 242-6900

GEORGIA
Fax: (770) 775-5625

TEXAS
Fax: (972) 932-4795

NEVADA
Fax: (775) 972-1578