

Item #: _____ **Qty #:** _____

Model #: _____

Project #: _____



LR4

FEATURES:

Curved top design.

Heavy duty welded construction with 6 cross supports.

Heavy duty 5" stem bolted swivel casters.

1 1/2" Ribbed Angles.

CONSTRUCTION:

Fully welded 1" square tubing ladder assembly.

MATERIAL:

6063-T52 extruded aluminum angles, upright tubing, and support pieces.



LR2

MODEL #	Lug Capacity	Overall Size L x W x H	Wt.
LR6	6	19" x 26" x 69 3/4"	20 lbs.
LR4	4	19" x 26" x 52 3/4"	16 lbs.
LR2	2	19" x 26" x 31 3/4"	14 lbs.
LR1	1	15 3/4" x 23 1/2" x 18 3/4"	12 lbs.

DIMENSIONS and SPECIFICATIONS

TOL ± .500"

ALL DIMENSIONS ARE TYPICAL

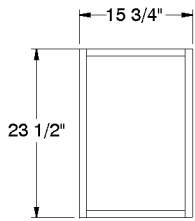

LR1

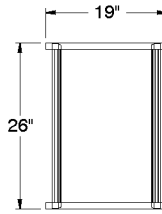
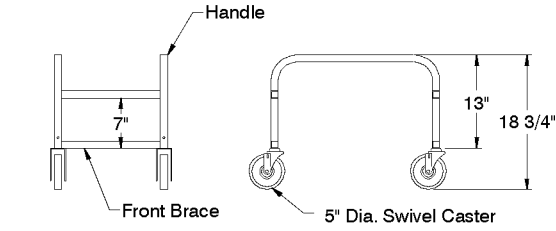

LR2

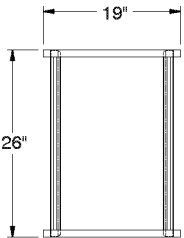
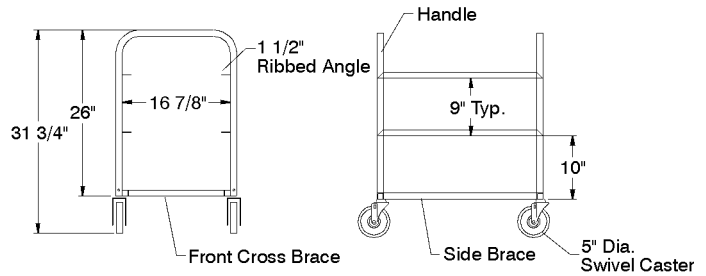

LR4

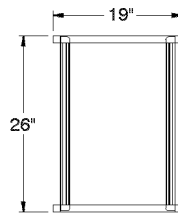
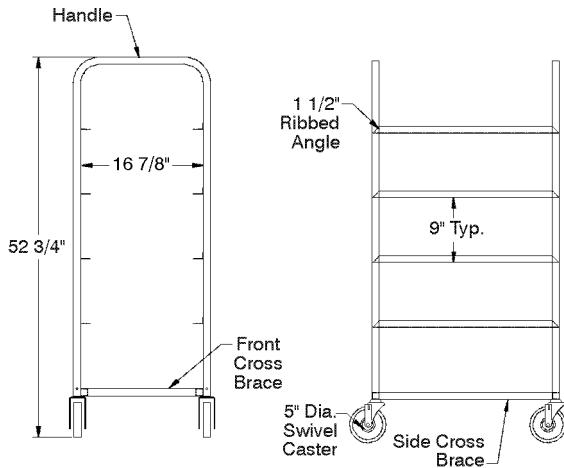

LR6

