

STAINLESS STEEL WALL MOUNTED TABLES

Item #: _____ **Qty #:** _____

Model #: _____

Project #: _____



1 1/2" Backsplash - FSS-W Series



1 1/2" Backsplash - FSS-W Series
(shown with optional Sink Bowl)

Width x Length	1 1/2" Backsplash	Approx. Wt.
24" x 30"	FSS-W-240	42 lbs.
24" x 24"	FSS-W-242	25 lbs.
24" x 36"	FSS-W-243	53 lbs.
24" x 48"	FSS-W-244	64 lbs.
24" x 60"	FSS-W-245	74 lbs.
24" x 72"	FSS-W-246	85 lbs.
24" x 84"	FSS-W-247	103 lbs.
24" x 96"	FSS-W-248	114 lbs.
30" x 30"	FSS-W-300	52 lbs.
30" x 24"	FSS-W-302	47 lbs.
30" x 36"	FSS-W-303	59 lbs.
30" x 48"	FSS-W-304	72 lbs.
30" x 60"	FSS-W-305	85 lbs.
30" x 72"	FSS-W-306	93 lbs.
30" x 84"	FSS-W-307	113 lbs.
30" x 96"	FSS-W-308	126 lbs.

SINK BOWLS
(Faucet & Basket
Drain Included)

Model #	Qty.
TA-11A	
TA-11B	
TA-11C	
TA-11D*	
TA-11F	
TA-11J	

* = Only Installed in
Countertops 30" or wider

FEATURES:

Unit is secured to wall by fastening TOP to a Steel-Dart Design-Angle, which is first secured to wall. A 1 5/8" tubular WALL BRACKET furnishes additional support when fastened to a steel wall mounted embossed flange.

Table furnished with 1-5/8" sanitary rolled rim "Bullnose" edge on front, and square edge on sides.

Single metal thickness 1-1/2" Backsplash on the rear edge.

CONSTRUCTION:

All TIG welded. Exposed weld areas polished to match adjacent surfaces.

Entire top mechanically polished to a satin finish. VKS-W Countertop edge polished to a MIRROR finish.

Top is sound deadened.

Roll formed embossed galvanized hat channels are secured to top by means of structural adhesive and weld studs.

MATERIAL:

TOPS: 14 gauge stainless steel type "304" series.

WALL BRACKETS: 1 5/8" diameter 16 gauge type "304" stainless steel tubing.

WALL ANGLE: 12 gauge galvanized steel

WALL FLANGES: Stainless steel embossed 5 3/4" diameter.

DETAILS and SPECIFICATIONS

TOL \pm .500"

ALL DIMENSIONS ARE TYPICAL

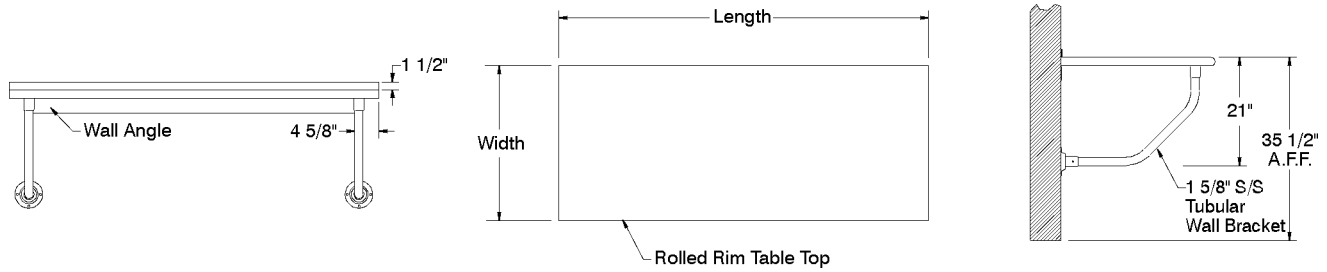

Wall Angle Detail

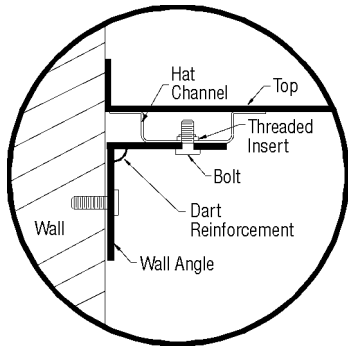

Wall Flange Detail

