



N1322 - 1300lb Nugget Ice Machine

Prodigy Plus[®] Nugget Ice Machine



Features & Benefits

- Available in softer, Original Chewable Nugget Ice and harder, H² Nugget Ice
- Sealed, maintenance-free bearings for reduced preventative maintenance and long-lasting performance
- Stainless steel evaporator and auger for maximum durability
- AutoAlert™ indicator lights for better visibility
- Operational footprint among the industry's smallest
- Unit specific QR code for quick access to service manuals, cleaning guides and warranty history
- Front-breathing - No side clearance required for flexible placement
- Smart-Board™ advanced feature module available for additional diagnostic capabilities
- Optional Vari-Smart™ ice level control allows operators to customize ice levels
- Antimicrobial protection guards internal surfaces between cleanings
- A full range of water- and energy-saving features



24 Hour Volume Production

Original Chewable Nugget

Air Cooled		Remote Cooled		Water Cooled	
70°F/21°C 50°F/10°C	Air Water	90°F/32°C 70°F/21°C	70°F/21°C 50°F/10°C	Air Water	90°F/32°C 70°F/21°C
1385/630 lb/kg		954/433 lb/kg	1360/618 lb/kg	1077/489 lb/kg	1513/688 lb/kg



24 Hour Volume Production

H² Nugget

Air Cooled		Remote Cooled		Water Cooled	
70°F/21°C 50°F/10°C	Air Water	90°F/32°C 70°F/21°C	70°F/21°C 50°F/10°C	Air Water	90°F/32°C 70°F/21°C
1186/538 lb/kg		866/393 lb/kg	1191/540 lb/kg	1000/454 lb/kg	1242/563 lb/kg

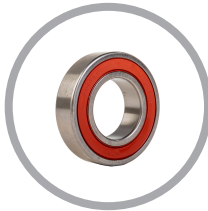

Sealed, maintenance-free bearings ensure maximum reliability and contribute to a long machine life

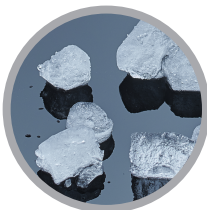

Available in softer, Original Chewable Nugget Ice or harder, H² Nugget Ice



Modular Bin & Dispenser Options

Model Number*	Dimensions W" x D" x H"	Bin Application		Ship Weight lb/kg
		Capacity lb/kg	Finish	
B948S	48 x 34 x 44**	893/406	Metallic	209/95
BH1100BB-A	48 x 34 x 50**	1100/499	SS w/ GBB†	280/127
BH1100SS-A	48 x 34 x 50**	1100/499	Stainless Steel	280/127
BH1300BB-A	60 x 34 x 50**	1400/635	SS w/ GBB†	310/141
BH1300SS-A	60 x 34 x 50**	1400/635	Stainless Steel	310/141
BH1600BB-A	60 x 34 x 62**	1755/796	SS w/ GBB†	370/168
BH1600SS-A	60 x 34 x 62**	1755/796	Stainless Steel	370/168

*Contact Scotsman for bin top requirements. **Add 6" Height for bin legs.
† Stainless steel with galvanized back & bottom.



Nugget Ice

Original Chewable Nugget Ice Hardness Rating:
Soft = 74%

H² Nugget Ice Hardness Rating:
Hard = 86%



Certification



Warranty

- 3 years parts and labor on all components.
- 5 years parts on the compressor.
- Warranty valid in North, South & Central America for commercial installations.
- Contact factory for warranty in other regions.
- Residential Applications: 1 year parts and labor



N1322 - 1300lb Nugget Ice Machine

Prodigy Plus® Nugget Ice Machine

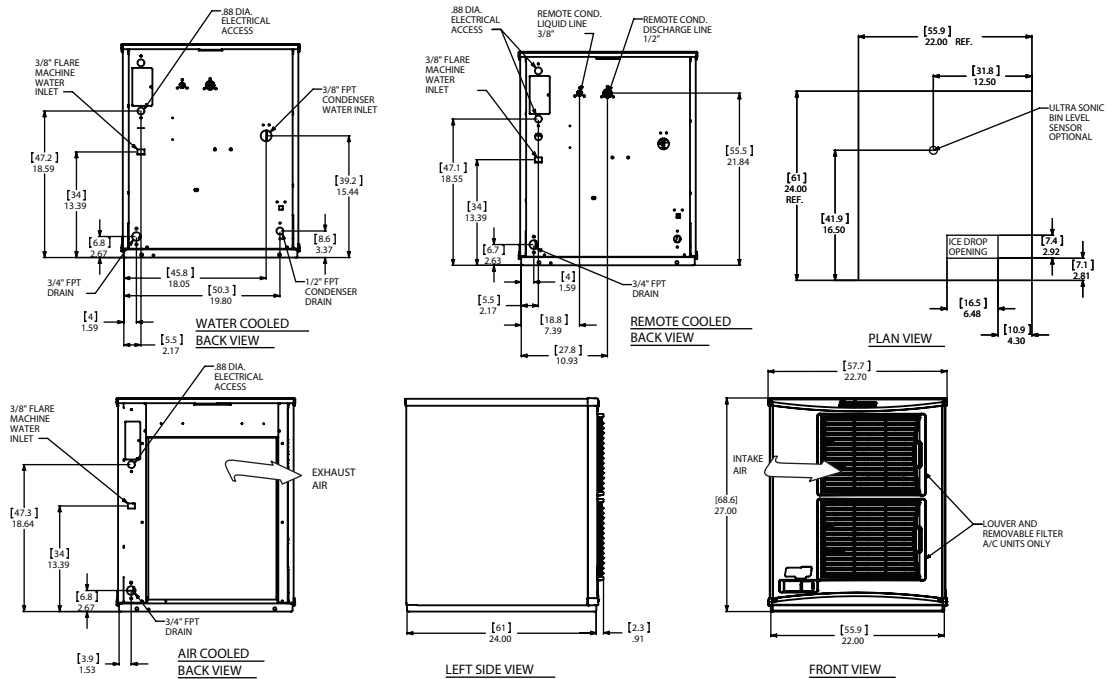

Specifications

Model Number	Condenser Unit	Basic Electrical Volts/Hz/Phase	Max. Fuse Size or HACR Circuit Breaker (amps)	Circuit Wires	Min. Circuit Ampacity	Energy Consumption kWh/100 lb (45.4 kg) 90°F(32°C)/70°F(21°C)	Water Usage Gallons/100 lb (liters/45.4 kg)		
							Potable 90°F(32°C)/70°F(21°C)	Condenser 90°F(32°C)/70°F(21°C)	
Nugget Type: Soft or Hard									
soft	NS1322A-32	Air	208-230/60/1	30	2	19.1	5.02	12.0/45.5	-
	NS1322R-32	Remote	208-230/60/1	30	2	18.4	4.65	12.0/45.5	-
	NS1322W-32	Water	208-230/60/1	30	2	17.9	3.8	12.0/45.5	115/435.9
	NS1322W-3	Water	208-230/60/3	15	3	11.2	3.8	12.0/45.5	115/435.9
hard	NH1322A-32	Air	208-230/60/1	30	2	19.1	5.31	12.0/45.5	-
	NH1322R-32	Remote	208-230/60/1	30	2	18.4	4.77	12.0/45.5	-
	NH1322W-32	Water	208-230/60/1	30	2	17.9	3.87	12.0/45.5	125/473.8
	NH1322W-3	Water	208-230/60/3	15	3	11.2	3.87	12.0/45.5	125/473.8



All Models

Dimensions (W x D x H):

Unit: Individual
22.9" x 24" x 27"
(58.2 x 61.0 x 68.6 cm)

Side by Side
44" x 24" x 27"
(111.8 x 61.0 x 68.6 cm)

Shipping Carton: 25.5" x 27.5" x 32.5"
(64.8 x 69.9 x 82.6 cm)

Shipping Weight: 225 lb / 102 kg

BTUs per hour: 16,000

Refrigerant: R-404A



Accessories

Model Number	Description
KVS	Vari-Smart™ Ice Level Control - Program ice bin levels to match ice needs.
KSBU	Smart-Board™ Advanced Control - Use additional operational data for fast diagnosis.
KSBU-N	Smart-Board™ Advanced Control with Network - Network capable.
ERC311-32A	Remote condenser for N1322R, 208-230V/60/1
BRTE10	Line set, 10ft, brazing required.
BRTE25	Line set, 25ft, brazing required.
BRTE40	Line set, 40ft, brazing required.
BRTE75	Line set, 75ft, brazing required.
KPAS	Prodigy Advanced Sustainability Kit - Includes KVS and KSBU - N

Scotsman recommends all ice machines have water filtration. See Scotsman water filter specification sheet for details.



Operating Requirements

	Minimum	Maximum
Air Temperatures	50°F (10°C)	100°F (38°C)
Water Temperatures	40°F (4.4°C)	100°F (38°C)
Remote Cond. Temps	-20°F (-29°C)	120°F (49°C)
Water Pressures	20 PSIG (1.4 bar)	80 PSIG (5.5 bar)
Electrical Voltage	-5%	+10%

Specifications and design are subject to change without notice.

N1322 - 1300lb Nugget Ice Machine