

# C-SERIES RESTAURANT RANGE 60" SERIES

## Standard Exterior Features

- 60-3/4" wide open top with eight (10) 28,000 BTU NAT (24,000 BTU LP) **PATENTED**, one-piece cast iron, non-clog burners with Lifetime Warranty.
- Stainless steel front, sides and removable shelf.
- 4" Stainless steel front rail with closed, welded end caps
- Ten (10) removable, cast iron grate tops (rear holds up to 14" stock pot)
- Two (2) removable, one-piece crumb drawer under burners
- Metal knobs w/ red stripe
- Hinged, lower valve panel
- Quadrant spring doors with ergonomic chrome handle
- 6" stainless steel, adjustable legs
- Factory installed pressure regulator

## Standard Oven Features (D)

- 35,000 BTU standard oven with snap action thermostat adjustable for 175°F to 550°F
- U-shaped heavy duty oven burner
- Equipped with flame failure safety device
- Large 26" wide X 26-1/2" deep oven with all oven cavity parts enameled
- Four sides and top of oven insulated with heavy, self-supporting block type rock wool with oven baffle assembly
- 2-position rack guides with one removable rack

C60DD - 10 Open Burners, 2 Standard Ovens



Job

Item#

[Click here to buy now!](#)

(C60DD)

**Central**  
RESTAURANT PRODUCTS

**1-866-285-1252**

## BIDDING SPECIFICATION

The unit shall be a 60-3/4" wide, S-Series Restaurant Range with ten (10) 28,000 BTU NAT (24,000 BTU LP) open top burners with ten (10) removable cast iron grate tops. The exterior of the unit shall be constructed of stainless steel and have a 4" stainless steel front rail with closed, welded end caps. The unit shall have 6" stainless steel, adjustable legs. The unit shall come with a 22.5" high stainless steel flue riser with single shelf. The unit shall come with a factory installed regulator.

**D** - The unit shall have a 35,000 BTU standard oven with snap action thermostat, adjustable from 175° F to 550° F. The interior shall be enameled and measure 26" wide X 26.5" deep X 14" high, and includes 2-position rack guides with one removable rack.



Models:  C60DD

Dimensions -in (mm)

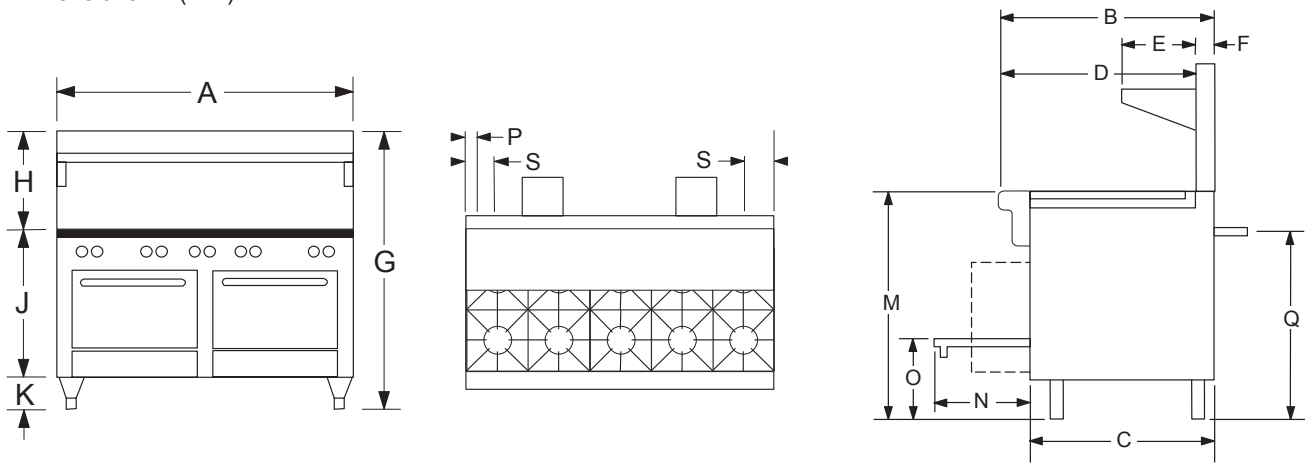

MODEL	EXTERIOR											COOK TOP M	DOOR OPENING N	OVEN BOTTOM O	3/4" GAS CONN.	
	Width A	Depth B	C	D	E	F	G	H	J	K	L				P	Q
C60DD	60.75" (1543)	34.00" (864)	29.75" (756)	31.00" (787)	10.00" (254)	2.75" (70)	59.50" (1511)	22.50" (572)	31.00" (787)	6.00" (152)	-	37.00" (940)	15.50" (394)	13.00" (330)	3.25" (83)	30.25" (768)

MODEL	OVEN INTERIOR			CRATE SIZE			CUBIC VOLUME	CRATED WEIGHT
	WIDTH	DEPTH	HEIGHT	WIDTH	DEPTH	HEIGHT		
C60DD	26.00" (660)	26.50" (673)	14.00" (356)	67.00" (1702)	45.50" (1158)	75.00" (1905)	132.3 cu. ft 3.75 cu.m.	860 lbs. 390 kg.

### UTILITY INFORMATION

Gas Type	BURNERS (BTU/EACH)			
	OPEN TOP BURNER	SPACE SAVER OVEN	STANDARD OVEN	CONVECTION OVEN
Natural	28K	35K	35K	35K
LP	24K	35K	35K	35K

- Each unit has a 3/4", male, rear gas connection.
- Minimum inlet pressure - Natural Gas is 7" W.C  
- Propane Gas is 11" W.C.
- For installation on combustible floors (with 6" high legs or casters) and adjacent to combustible walls, allow 10" clearance.
- Check local codes for fire, installation and sanitary regulations.
- Clearance to noncombustible construction is 0" for all tops and bases.

- If using Flex-Hose, the I.D. should not be smaller than the I.D. of the manifold of the unit to which it is being connected.
- Install under vented hood.
- If the unit is connected directly to the outside flue, an CSA approved down draft diverter must be installed at the flue outlet of the oven.

**Notice:** X^) â[ ; reserves the right to change specifications and product design without notice. Such revisions do not entitle the buyer to corresponding changes, improvements, additions, or replacements for previously purchased equipment.

**INTENDED FOR COMMERCIAL USE ONLY.  
NOT FOR HOUSEHOLD USE.**