



Project Name:	
Location:	
Item:	Qty.:
Model:	

## 69K-023, 69K-024 & 69K-025

## Commercial Drink Dispenser



### FEATURE LIST

Model:	69K-023	69K-024	69K-025
Capacity:	1 3-Gallon Bowl	2 3-Gallon Bowls	3 3-Gallon Bowls
Power:	300 Watts	420 Watts	500 Watts
Voltage:	120/60/1 220/50/1 220/60/1	120/60/1 220/50-60/1	120/60/1 220/50/1 220/60/1
Shipping Weight:	42 LB / 19 KG	69 LB / 31 KG	86 LB / 39 KG
Dimensions:	8" W x 17" D x 24"H 203mm W x 432mm D x 610mm H	16" W x 17" D x 24"H 203mm W x 432mm D x 610mm H	24" W x 17" D x 24"H 203mm W x 432mm D x 610mm H

## 69K-023, 69K-024 & 69K-025 Commercial Drink Dispensers

Central Restaurant Products' High Performance Drink Dispensers represent the ideal way to present drink products to your customer. Compactly designed with space saving in mind, our drink dispensers provide the highest level of performance in the smallest amount of space. A continuously circulating rotary system keeps the product fresh and perfectly consistent each and every time. They are built to withstand

daily use in fast-paced environments using durable materials like stainless steel and high-impact plastics. Add in the ease of use and short time required for cleaning and maintenance, and there is little doubt that this machine is a winner.



Specifications subject to change without notice.

Approvals: ETL, ETL Sanitation



7750 Georgetown Road • Indianapolis, IN 46268  
800-289-3637 • Fax 800-882-0086  
[www.CentralRestaurant.com](http://www.CentralRestaurant.com)

Delivering Expert Solutions with the Personal Attention You Deserve

Project Name:

Location:

Item:

Qty:

Model:

**69K-023, 69K-024 & 69K-025****PLAN VIEW**

Commercial Drink Dispenser

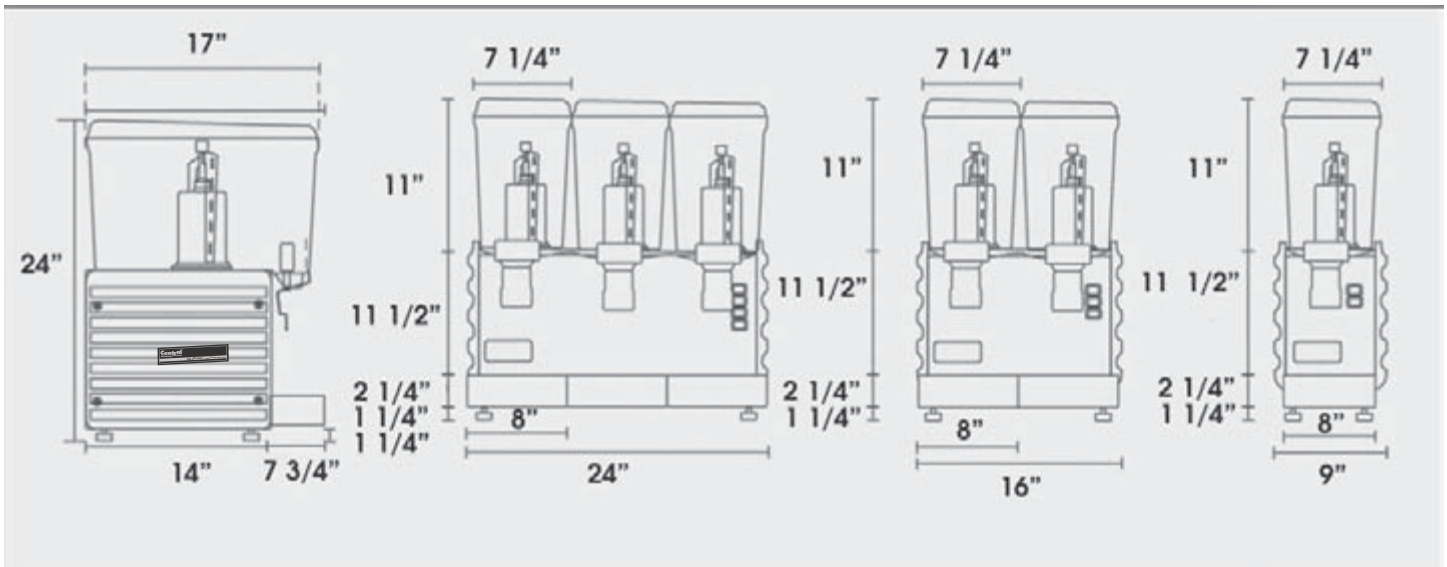
**69K-023, 69K-024 & 69K-025**

Central Restaurant Products' high performance Drink Dispensers represent the ideal way to present drink products to your customer. Compactly designed with space saving in mind, our drink dispensers provide the highest level of performance in the smallest amount of space. A continuously circulating rotary system keeps the product fresh and perfectly consistent each and every time. They are built to withstand

daily use in fast-paced environments using durable materials like stainless steel and high-impact plastics. Add in the ease of use and short time required for cleaning and maintenance, and there is little doubt that this machine is a winner.

- Continuous Rotary System for Product Consistency
- Durable Clear Polycarbonate 3 Gallon Bowls
- Stainless Steel Cooling Cylinder, Frame, and Front Panel
- Removable Drip Trays for Easy Cleaning
- Compact Design Saves Counter Space
- Easy Push Button Control System
- No-drip Stainless Steel Dispensing Mechanism
- Engineered for long-life with little maintenance