

Click here to buy now!

12in. SLICER (250 mm)

Model: GSE012 International Model: Add -50 (220V/50Hz/1Ph)

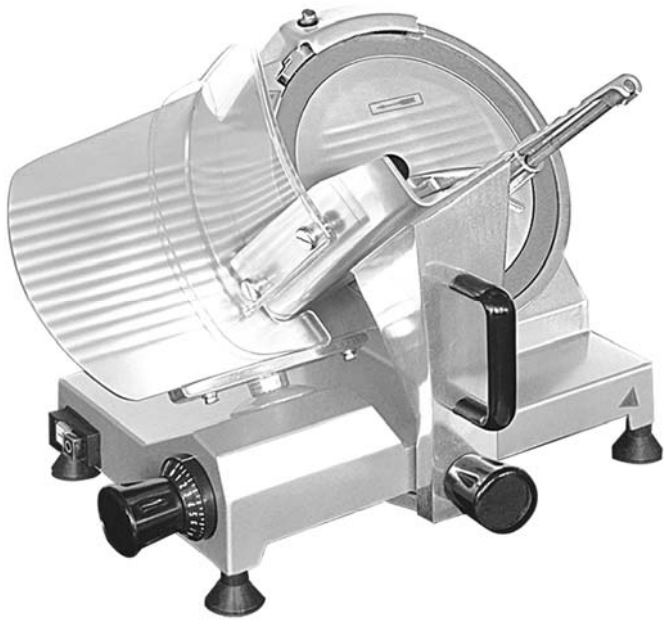

12" manual gravity feed slicer features a compact design. Ideal for for coffee shops, small restaurants, sandwich shops, catering, delicatessens and more! Suited to handle low volume slicing on a continuous use basis for a variety of vegetables and processed meats. Not designed or recommended for slicing raw or frozen products or cheeses. Appropriate for low-volume applications of less than 2 hours of slicing per day.

TECHNICAL DATA

BLADE DIAMETER	12 in (300 mm)
BLADE ROTATION SPEED	308 RPM
MINIMUM CUT THICKNESS	1/25 in (1 mm) - Deli Thin
MAXIMUM CUT THICKNESS	3/5 in (15 mm)
CUT CAPACITY WIDTH	8.7 in (220 mm)
VOLTAGE	115V/60Hz/1ph 220V/50Hz/1ph
POWER (HP)	0.33 ~ 1/3
POWER (Watts)	250w

ADDITIONAL FEATURES

- Stain resistant cast anodized aluminum finish
- Mounted full knife rim guard, regulator plate lock, and knife cover interlock for safe operation and cleaning.
- Includes a high carbon, chrome plated knife with sharpener.
- Efficient and powerful "high torque" knife drive system ensures consistent power transfer for smooth operation.
- 4 rubberized legs ideal for countertop use, wont slip or scratch/mark the surface.

ELECTRIC

- 115V/60Hz/1-ph, NEMA 5-15P
 - 6-1/2 ft power cord and plug set
- Also available:
- 220V/50Hz/1-ph



An appropriate Int'l Cord Set and plug to be provided when specified on the order. If no Cord Set or Plug is specified, NEMA 6-15 is the default.

General WARRANTY (USA / CANADA)

One (1) year parts
One (1) year on-site labor
Administered by The Legacy Companies, 877.368.2797
Warranty is limited to a period of one (1) year from the date of original installation or 15 months after shipment date from The Legacy Companies, whichever occurs first.



Product design and specifications are subject to modification by manufacturer without prior notice.

The built in performance enhancing functions ensure that given proper attention and preventative maintenance, each General product will deliver years of trouble free, reliable, low maintenance, efficient operation.

Click here to buy now!

Central[®]
RESTAURANT PRODUCTS
WHOLESALE EQUIPMENT & SUPPLIES

1-866-285-1252

12in. SLICER (250 mm)

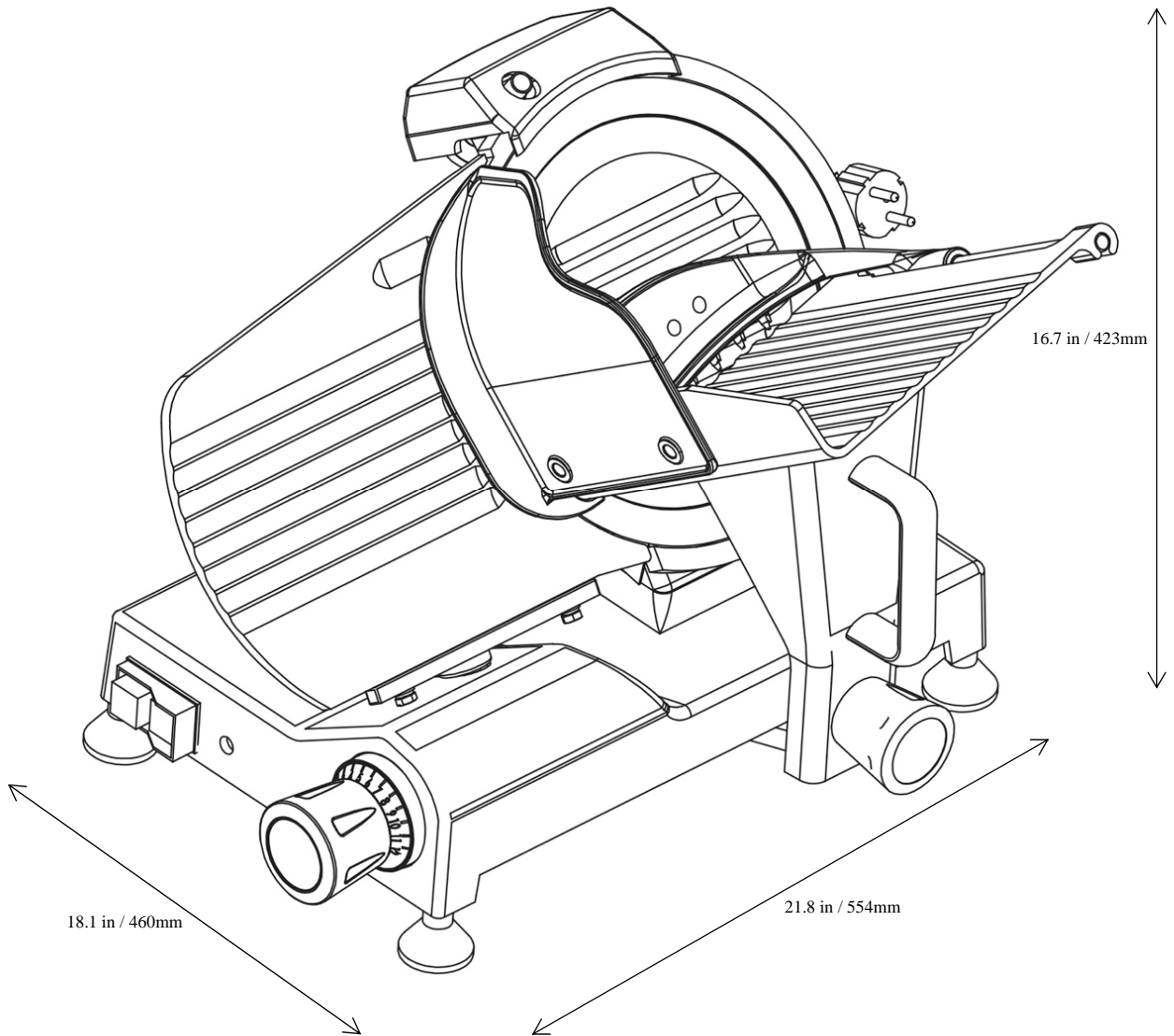

DIMENSIONS 21.8 x 18.1 x 16.7in / 554 x 460 x 423mm

SHIP DIMENSIONS 24.2 x 20.7 x 19.7in / 615 x 525 x 500mm

NET WEIGHT 46.52 lb / 21.1 kg

SHIP WEIGHT 52.91 lb / 24 kg

Product design and specifications are subject to modification by manufacturer without prior notice.

The built in performance enhancing functions ensure that given proper attention and preventative maintenance, each General product will deliver years of trouble free, reliable, low maintenance, efficient operation.