



7750 Georgetown Road
Indianapolis, IN 46268
800-289-3637 • Fax 800-882-0086

Project Name: _____
Location: _____
Item #: _____ Qty: _____
Model: _____

COUNTERTOP MERCHANDISERS | FREEZERS

Model: 69K-153 69K-154 69K-155 69K-156



69K-153



69K-154



69K-155



69K-156

Countertop Glass Door Merchandisers are designed for durability and visual appeal in promoting your product. Glass door merchandisers are energy efficient and effective at keeping product at exactly the right temperature. This keeps food fresher for longer. The simple-to-use but precise digital controls allows for accuracy in temperature and flexible use of the unit.

FEATURES

- Hinged Door Models: Self-closing, magnetic gasket.
- Perimeter magnetic compression gaskets contribute to the unit's operating efficiency and are readily replaced without tools.
- Door locks
- Triple pane glass doors enhance energy efficiency by preventing heat loss and minimizing condensation
- Interior LED lighting
- Internal hidden bottom mounted compressor
- Automatic defrost cycle maintains ideal storage conditions.
- Digital Temperature display can be recessed in top of unit or raised for easy viewing. Temperature reading visible from up to 15 feet away.
- Adjustable feet for uneven flooring.
- Internal condensate evaporate pan included. No drain connection is needed.
- Foamed urethane insulation is used to minimize heat loss and improve the unit's temperature regulation, resulting in cost effective performance
- Heavy-duty, PE (polyethylene) coated wire shelves.
 - 69K-153 and 69K-154: (2) shelves
 - 69K-155 and 69K-156: (3) shelves

REFRIGERANT

- CFC & HCFC free R-134A

ELECTRIC

Single Door: 115/60Hz/1 Ph (NEMA 5-15)



TEMPERATURE

- Holding temperature: 0° to 10°F (-18° to -12°C)
- Digitally controlled system maintains optimum temperature

CONSTRUCTION

- Exterior Material: White painted steel.
- Interior Material: ABS. Easy to clean, low maintenance.



WARRANTY (USA / CANADA)

Three (3) year parts
Three (3) year on-site labor
Four (4) years compressor (part only)
Administered by Central, 800-289-3637

Due to periodic changes in designs, methods, procedures, policies and regulations, the specifications contained in this sheet are subject to change without notice. While we exercise good faith efforts to provide information that is accurate, we are not responsible for errors or omissions in information provided or conclusions reached as a result of using the specifications. By using the information provided, the user assumes all risks in connection with such use.

The built in performance enhancing functions ensure that given proper attention and preventative maintenance, each Central Product will deliver years of trouble free, reliable, low maintenance, efficient operation.

V1_042117

COUNTERTOP MERCHANDISERS | FREEZERS

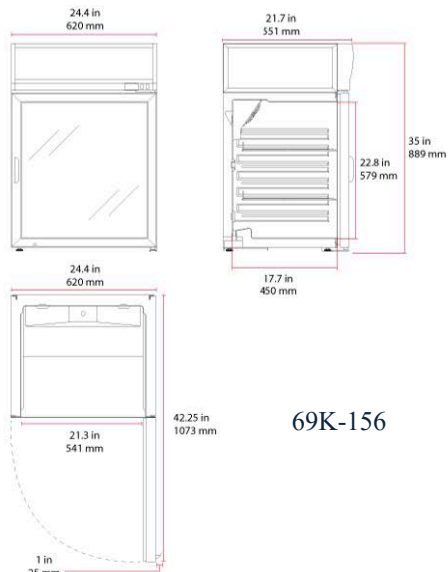
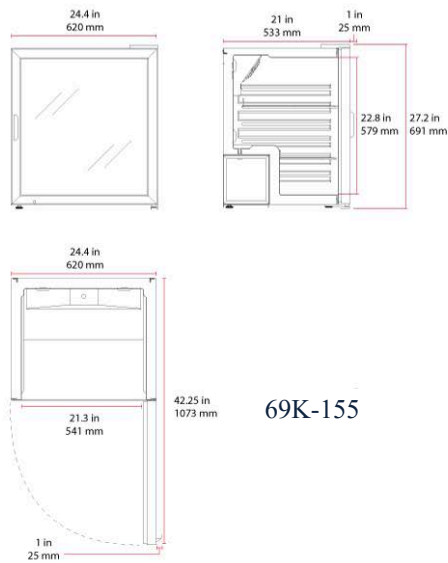
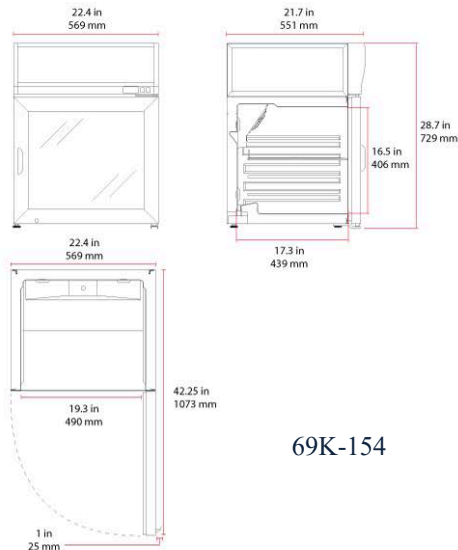
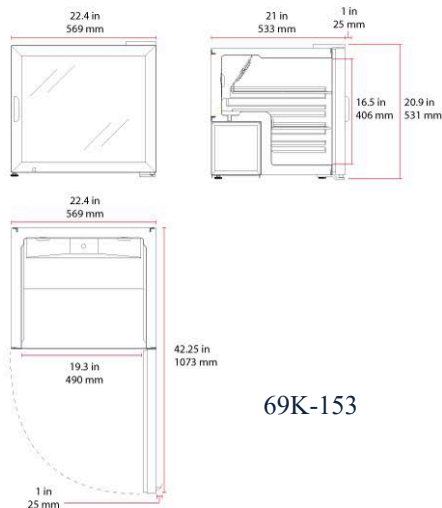

	69K-153	69K-154	69K-155	69K-156
In: External Dimensions W x D X H	22.3 x 21 x 20.9	22.3 x 21.7 x 28.7	24.3 x 21.4 x 27.2	24.3 x 22 x 35
mm: External Dimensions W x D X H	570 x 533 x 530	570 x 550 x 730	620 x 543 x 691	620 x 560 x 890
Nominal Capacity	2.1 Cu Ft / 59.5 L	2.6 Cu Ft / 73.5 L	3.5 Cu Ft / 102 L	4.2 Cu Ft / 119 L
Doors	1	1	1	1
Shelves	(2) shelves	(2) shelves	(3) shelves	(3) shelves
Unit Weight	101.4 lb / 46kg	115 lb / 52kg	123.5 lb / 56kg	143 lb / 65kg

Due to periodic changes in designs, methods, procedures, policies and regulations, the specifications contained in this sheet are subject to change without notice. While we exercise good faith efforts to provide information that is accurate, we are not responsible for errors or omissions in information provided or conclusions reached as a result of using the specifications. By using the information provided, the user assumes all risks in connection with such use.