



KRATOS EQUIPMENT  
 7750 Georgetown Road, Indianapolis, IN 46268  
 Sales: (317) 634-2550  
 Tech Service: (887) 368-2797

Project Name: \_\_\_\_\_  
 Location: \_\_\_\_\_  
 Item #: \_\_\_\_\_ Qty: \_\_\_\_\_  
 Model: \_\_\_\_\_

# SOLID TOP CHEST FREEZERS

Model:  69K-743HC  69K-744HC  69K-745HC



69K-743HC



69K-744HC



69K-745HC

KRATOS solid hinged lid chest freezers are an excellent option for safely storing frozen food products such as meat, packaged foods, ice cream, vegetables, desserts and bags of ice while keeping them at the ideal storage temperature for extended life, maintaining quality and taste, preventing freezer burn and development of ice crystals. The stored product is easily accessible when it's time to use any of the contents. The included interior storage basket(s) helps you organize your products, so you can quickly locate and retrieve what you need. The refrigeration system is oversized so this unit can be used safely in a garage even if the temperature drops to 0°F or rises above 100°F. The hinged lid includes a lock and key to prevent unauthorized access to the contents. The freezer is sized to pull down its contents temperature level if loaded with pre-chilled products (recommended loading temperature for all products is ≤ 41°F/5°C). The freezer design will provide years of reliable operation if properly maintained.

## FEATURES

- Sturdy hinged top opening lid that opens up to 90° makes access and servicing the freezer easy
- Includes lock to provide security even if unattended
- Utilizes R-600A refrigerant
- One(1) white wire storage basket included for easy product organization
- Can hold the contents safely for 2 days in case of a power outage

## TEMPERATURE

- Holding temperature: 0° to 11°F (-24° to -18° C)
- Readily adjustable temperature set point (factory set at 5°F / -15°C)
- Rapid temperature recovery after opening lid
- Chest freezers hold frozen foods better than upright freezers as the cold air is retained in the storage compartment even if the lid is not fully closed

## CONSTRUCTION

- Exterior Material: White powder coated steel
- Interior Material: Aluminum
- Flat top-opening insulated lid with integrated external handle
- 3" of environmentally friendly foam insulation can hold the stored contents safely for 2 days in case of a power outage
- Oversized yet energy efficient refrigeration system meets 2017 DOE requirements and its rapid recovery capability results in approval of using these models for commercial applications
- Cold wall construction for even temperature profile in the chest freezer
- Manual defrost capability is provided to keep the walls frost-free and deliver the coldest possible contents
- Interior storage compartment is made from corrosion resistant materials

## REFRIGERANT

- CFC & HCFC free R-600A

## ELECTRIC

115V/60Hz/1 Ph (NEMA 5-15P)  
 Comes with a 6' (1.85m) Cord Set

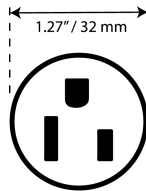

NEMA 5-15P

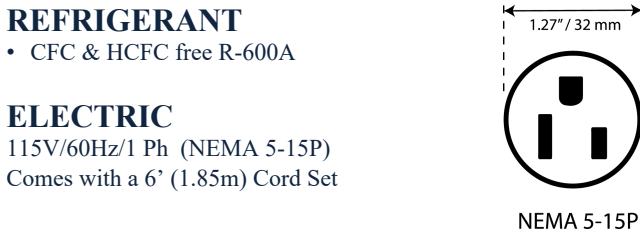

Intertek  
 Certified to  
 ANSI-NSF 7



Certified to  
 ANSI UL 471



DOE 2017  
 Compliant

## KRATOS WARRANTY (USA / CANADA)

One (1) year parts  
 One (1) year on-site labor  
 Four (4) additional years (Five (5) total) for the compressor (part only)  
 Administered by KRATOS EQUIPMENT, 887.368.2797  
 24/7 tech support provided

Due to periodic changes in designs, methods, procedures, policies and regulations, the specifications contained in this sheet are subject to change without notice. While we exercise good faith efforts to provide information that is accurate, we are not responsible for errors or omissions in information provided or conclusions reached as a result of using the specifications.

By using the information provided, the user assumes all risks in connection with such use.

The built in performance enhancing functions ensure that given proper attention and preventative maintenance, each KRATOS will deliver years of trouble free, reliable, low maintenance, efficient operation.



KRATOS EQUIPMENT  
 7750 Georgetown Road, Indianapolis, IN 46268  
 Sales: (317) 634-2550  
 Tech Service: (887) 368-2797

Project Name: \_\_\_\_\_  
 Location: \_\_\_\_\_  
 Item #: \_\_\_\_\_ Qty: \_\_\_\_\_  
 Model: \_\_\_\_\_

# SOLID TOP CHEST FREEZERS

69K-743HC

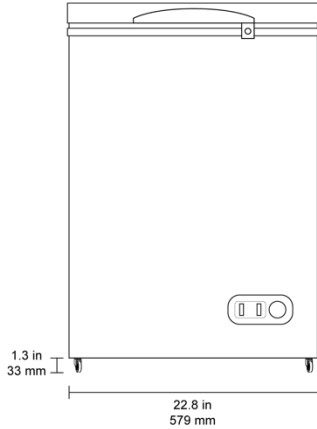

69K-744HC

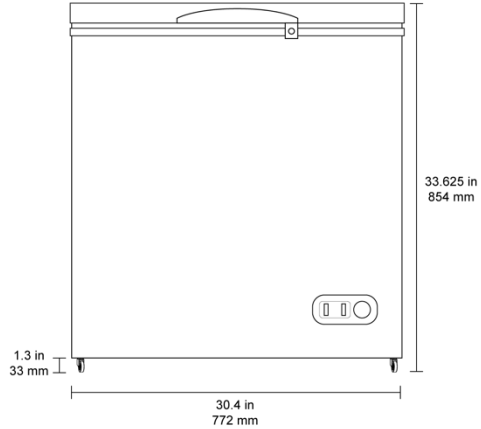

69K-745HC

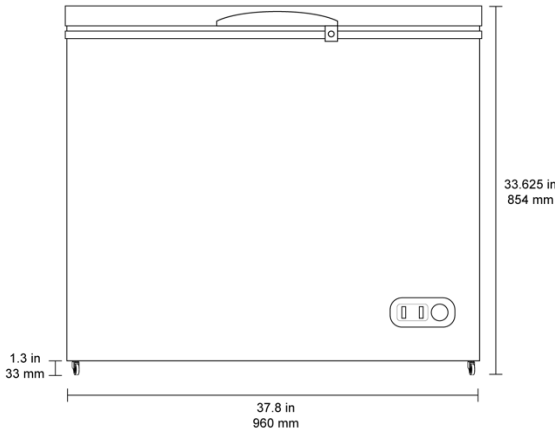

SIDE VIEW (ALL)

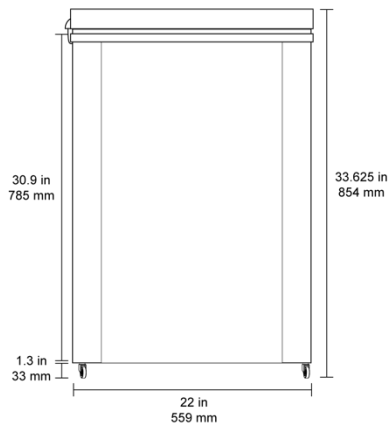

	69K-743HC	69K-744HC	69K-745HC
<b>In: External Dimensions W x D x H</b>	22.8 x 22 x 33.625	30.4 x 22 x 33.625	37.8 x 22 x 33.625
<b>mm: External Dimensions W x D x H</b>	579 x 559 x 854	772 x 559 x 854	960 x 559 x 854
<b>Capacity</b>	3.4 Cu Ft / 96 L	5.2 Cu Ft / 147 L	7.0 Cu Ft / 198 L
<b>Manual Defrost</b>	Yes	Yes	Yes
<b>Voltage / Frequency</b>	115V/60Hz	115V/60Hz	115V/60Hz
<b>Average Amp Draw (Watts)</b>	0.36 (60)	0.5 (90)	0.5 (95)
<b>Temperature Range F°/C°</b>	0° to 11° F -24° to -18° C	0° to 11° F -24° to -18° C	0° to 11° F -24° to -18° C
<b>Factory Temperature Setting</b>	5°F (-15°C)	5°F (-15°C)	5°F (-15°C)
<b>Unit Weight</b>	67 lb (30 kg)	78 lb (35 kg)	88 lb (40 kg)
<b>Shipping Weight</b>	75 lb (34 kg)	92.6 lb (42 kg)	99.2 lb (45 kg)

Due to periodic changes in designs, methods, procedures, policies and regulations, the specifications contained in this sheet are subject to change without notice.  
 While we exercise good faith efforts to provide information that is accurate, we are not responsible for errors or omissions in information provided or conclusions reached as a result of using the specifications.  
 By using the information provided, the user assumes all risks in connection with such use.